

Work Zone Safety & Mobility Policy and Guidance

PREPARED FOR

Vermont Agency of Transportation



FEBRUARY 24, 2021

This page intentionally left blank.

Table of Contents

	VTrans Work Zone Safety and Mobility Policy	1
	INTRODUCTION	1
	APPLICABILITY/CRITERIA.....	1
	ROLES AND RESPONSIBILITIES	1
	VISION	2
	WORK ZONE POLICY GOALS.....	2
	Safety	2
	Mobility.....	2
	Assessment and Improvement.....	2
	Training	2
1	Work Zone Safety and Mobility Guidance Procedures	3
	STATE-LEVEL PROCESSES AND PROCEDURES.....	3
	Strategies.....	3
	Training	5
	Assessment and Improvement Procedures (Process Review).....	9
	PROJECT-LEVEL PROCEDURES	10
	Strategies.....	10
	Project Significance.....	11
	TMP Development Process.....	19
	TTC Development	22
	TMP Implementation and Feedback Processes	24
2	Work Zone Safety and Mobility Strategies	25
	INTRODUCTION	25
	WORK ZONE MANAGEMENT STRATEGIES	26
	1) Temporary Traffic Control (TTC).....	28
	2) Transportation Operations (TO).....	36
	3) Public Information.....	42
3	Special Aspects of Work Zone Safety and Mobility.....	53
	POSITIVE PROTECTION DEVICES.....	53
	Positive Barrier Use Guidelines	54
	Exceptions.....	55

SAFE ENTRY AND EXIT OF THE WORK ZONE.....	56
INSTALLATION AND MAINTENANCE OF TRAFFIC CONTROL DEVICES.....	56
LAW ENFORCEMENT USE.....	56
Traffic Control Operations	57
Presence	57
Enforcement	58
Emergency Assistance	58
Pay for Uniform Traffic Control Officers.....	58
PAYMENT GUIDELINES FOR WORK ZONE TRAFFIC CONTROL ITEMS	59

Appendices

REFERENCES AND OTHER GUIDANCE.....	61
TMP CHECKLIST.....	65
VERMONT BICYCLE AND PEDESTRIAN WORK ZONE TRAFFIC CONTROL GUIDE.....	69

List of Tables

Table No.	Description	Page
Table 1	Work Zone State-Level Strategies	4
Table 2	Work Zone Required Training by Role	7
Table 3	Work Zone Project-Level Strategies.....	10
Table 4	Project Significance Criteria	15

List of Figures

Figure No.	Description	Page
FIGURE 1	WORK ZONE ROLES AND RESPONSIBILITIES	6
FIGURE 2	TMP DEVELOPMENT PROCESS.....	23

List of Acronyms

AADT	Average Annual Daily Traffic
AASHTO	American Association of State Highway Transportation Officials
ACEC	American Council of Engineering Companies
ADT	Average Daily Traffic
AFAD	Automated Flagger Assistant Devices
AGC	Associated General Contractors
ATSSA	American Traffic Safety Services Association
CFR	Code of Federal Regulations
CMGC	Construction Manager/General Contractor
CMS	Changeable Message Signs
DHV	Design Hour Volume
DMV	Department of Motor Vehicles
FHWA	Federal Highway Administration
HAR	Highway Advisory Radio
HOV	High-Occupancy Vehicle
ITS	Intelligent Transportation Systems
LMS	Learning Management System
MUTCD	Manual on Uniform Traffic Control Devices
NHI	National Highway Institute
PI	Public Information Plan
PM	Project Manager
PS&E	Plan, Specification and Estimate
ROW	Right-of-Way
TMA	Truck Mounted Attenuators
TMC	Transportation Management Center
TMP	Transportation Management Plan
TO	Transportation Operation
TTC	Temporary Traffic Control
VTrans	Vermont Agency of Transportation
VTTC	VTrans Training Center
WZRO	Work Zone Resource Officer

This page intentionally left blank.

VTrans Work Zone Safety and Mobility Policy

INTRODUCTION

To systematically address the safety and mobility impacts of work zones, the Vermont Agency of Transportation (VTrans) has established a Work Zone Safety and Mobility Policy and Guidance in compliance with Federal Highway Administration (FHWA) requirements outlined in 23 CFR 630 Subparts J and K. The Policy and Guidance provides tools and procedures to assess and analyze work zone impacts and to take appropriate actions to minimize and mitigate these impacts, while managing safety and mobility.

The document is divided into three sections:

Chapter 1 – Work Zone Safety and Mobility Guidance Procedures - 23 CFR 630 Subpart J

Chapter 2 – Work Zone Safety and Mobility Strategies - 23 CFR 630 Subpart K

Chapter 3 – Special Aspects of Work Zone Safety and Mobility - 23 CFR 630 Subpart J and K

APPLICABILITY/CRITERIA

Implementation of the Policy is required for all federal-aid highway projects and expected for all other construction and maintenance activities on Vermont highways. The Guidance document that follows provides clear direction and steps for implementing the Policy.

ROLES AND RESPONSIBILITIES

- › The Policy is administered by the Chief Engineer and intended for implementation by all Agency personnel, consultants, and contractors involved in work zone implementation on Vermont highways.
- › The Policy and Guidance are the responsibility of the Chief Engineer and the Work Zone Committee.
- › Roles of stakeholders responsible for implementing work zone project- and state-level processes and procedures are further defined in the Guidance.

VISION

VTrans has adopted the following Work Zone Safety and Mobility Vision Statement:

Provide optimum safety for highway workers and the traveling public while maintaining acceptable levels of mobility in a work zone environment to enable maintenance and construction activities on Vermont highways.

WORK ZONE POLICY GOALS

VTrans has established the following goals to guide Work Zone Safety and Mobility considerations and procedures.



Safety

To provide safe work zones for the traveling public (including motorists, pedestrians, bicyclists) and highway workers



Mobility

To maintain mobility and access for the traveling public through or around work zones



Assessment and Improvement

To improve work zone practices through assessment of effectiveness, performance, and work zone strategies



Training

To provide opportunities for personnel to develop the necessary knowledge and skills to plan, design, implement, monitor, review, and/or assess work zones for safety and mobility

This policy is effective for five years from adoption date.

Chief Engineer Signature

February 25, 2021

Date

Wayne B. Symonds, PE

Printed Signature

1

Work Zone Safety and Mobility Guidance Procedures

The VTrans Work Zone Safety and Mobility Guidance documents state- and project-level processes and procedures required to be compliant with VTrans Work Zone Safety and Mobility Policy and Federal Regulations. At both the state and project level, this chapter of the Guidance provides methods to help assess progress towards the Work Zone Policy Goals. At the state level, it details training and process review procedures; at the project level, it lays out procedures to determine project significance, develop project-appropriate transportation management plans (TMPs), and assess TMP implementation and modification.

STATE-LEVEL PROCESSES AND PROCEDURES



VTrans' state-level processes and procedures are grouped into four subject areas: safety, mobility, assessment and improvement, and training. The strategies and responsible parties are identified below.

Strategies

At the state level, VTrans has identified strategies that ensure work zone mobility and safety processes and procedures are managed, assessed, and improved upon. Table 1 below shows the state-level strategies associated with each goal and the entity responsible for execution of that strategy. To reach the Policy Goals, it is essential that a Work Zone Committee be formed to execute a number of the identified strategies. The Work Zone Committee is a VTrans-appointed committee consisting of:

- › VTrans staff—Chief Engineer (or designated appointee), Traffic Engineer (or designated appointee), and Work Zone Safety Engineer (or designated appointee)
- › A Federal Highway Administration (FHWA) representative
- › Representation from Associated General Contractors (AGC) and American Council of Engineering Companies (ACEC)

Table 1 Work Zone State-Level Strategies

	State-Level Strategies	Responsibility
Safety		
	Establish procedures for on-site monitoring of work zone safety measures and mitigation of safety issues.	Work Zone Committee
	Establish communication and feedback procedures for the life cycle of the project through concept, planning, design, construction, monitoring, and review.	Work Zone Committee
	Establish guidance and mechanism for traffic officer presence and traffic officer enforcement as appropriate.	VTrans Chief Engineer with input from Work Zone Committee
	Develop guidance on safety best practices.	Work Zone Committee
Mobility		
	Establish procedures for identifying potential travel delays associated with work zones and access limitations in planning and design.	Work Zone Committee
	Develop appropriate statewide criteria for context-sensitive maximum acceptable work zone related delays.	Work Zone Committee
	Establish statewide procedures for monitoring on-site/site-related travel delays.	Work Zone Committee
	Establish procedures for mitigating project related travel delays and/or access limitations.	Work Zone Committee
Assessment and Improvement		
	Collect and summarize project-level evaluations to identify effective safety and mobility measures and improve work zone procedures.	Work Zone Committee
	Establish communication and feedback procedures for the life cycle of the project through concept, planning, design, construction, monitoring, and review.	Work Zone Committee
	Determine performance measures and targets for safety and mobility.	Work Zone Committee
	Disseminate effective procedures and measures to personnel and partnering entities.	Work Zone Committee, VTTC through training, VTrans Chief Engineer
	Conduct process reviews and update guidance and procedures to reflect feedback, assessments, and best practices.	Work Zone Committee
Training		
	Establish role-appropriate (planner, designer, reviewer, implementer, evaluator) personnel training programs by developing new or identifying existing training curricula.	VTTC and Work Zone Committee
	Gather feedback, conduct assessments, and identify best practices to update training programs and curricula.	VTTC and Work Zone Committee

Training

As outlined in Code of Federal Regulations 23 CFR Section 630.1008(d), all VTrans personnel, consultants, and contractors involved in the development, design, implementation, operation, inspection, and enforcement of work zone related transportation management and traffic control must be trained in a manner appropriate to the job decisions each individual is required to make. Each role will require specific courses; however, all professionals are encouraged to participate in additional training regarding work zone safety.

Training Administration

One Work Zone Resource Officer (WZRO) will be identified from each VTrans Bureau, contractor entity, and consultant entity and this person's name will be reported to the VTrans Training Center. The WZRO will ensure the proper training of staff in his or her organization to the level appropriate to their involvement in work zones. The WZRO will participate in advanced training courses and refresher courses as needed, which ensures the most up-to-date work zone safety and mobility strategies are disseminated through the VTrans, consulting, and contractor communities. Current advanced training includes the Advanced Work Zone Management and Design Course by FHWA and NHI or equivalent (Florida Advanced Training by ATSSA is one such course). Work Zone Resource Officers from each Bureau or entity are expected to meet at least annually to review process, training, and lessons learned among the different groups/companies.

At VTrans, the VTrans Training Center (VTTC) will be responsible for maintaining records of courses that staff have taken. The WZRO will be responsible for ensuring that staff is trained appropriately for their position by obtaining the list from VTTC annually and requiring staff to attend appropriate training. The Bureau WZROs and Consultant and Contractor WZROs will provide that documentation for all staff to the Work Zone Committee every two years. All staff should report trainings undertaken to their WZRO.

The VTTC will maintain the list of course offerings and develop training as needed to address gaps in availability of appropriate training options.

Figure 1 Work Zone Roles and Responsibilities

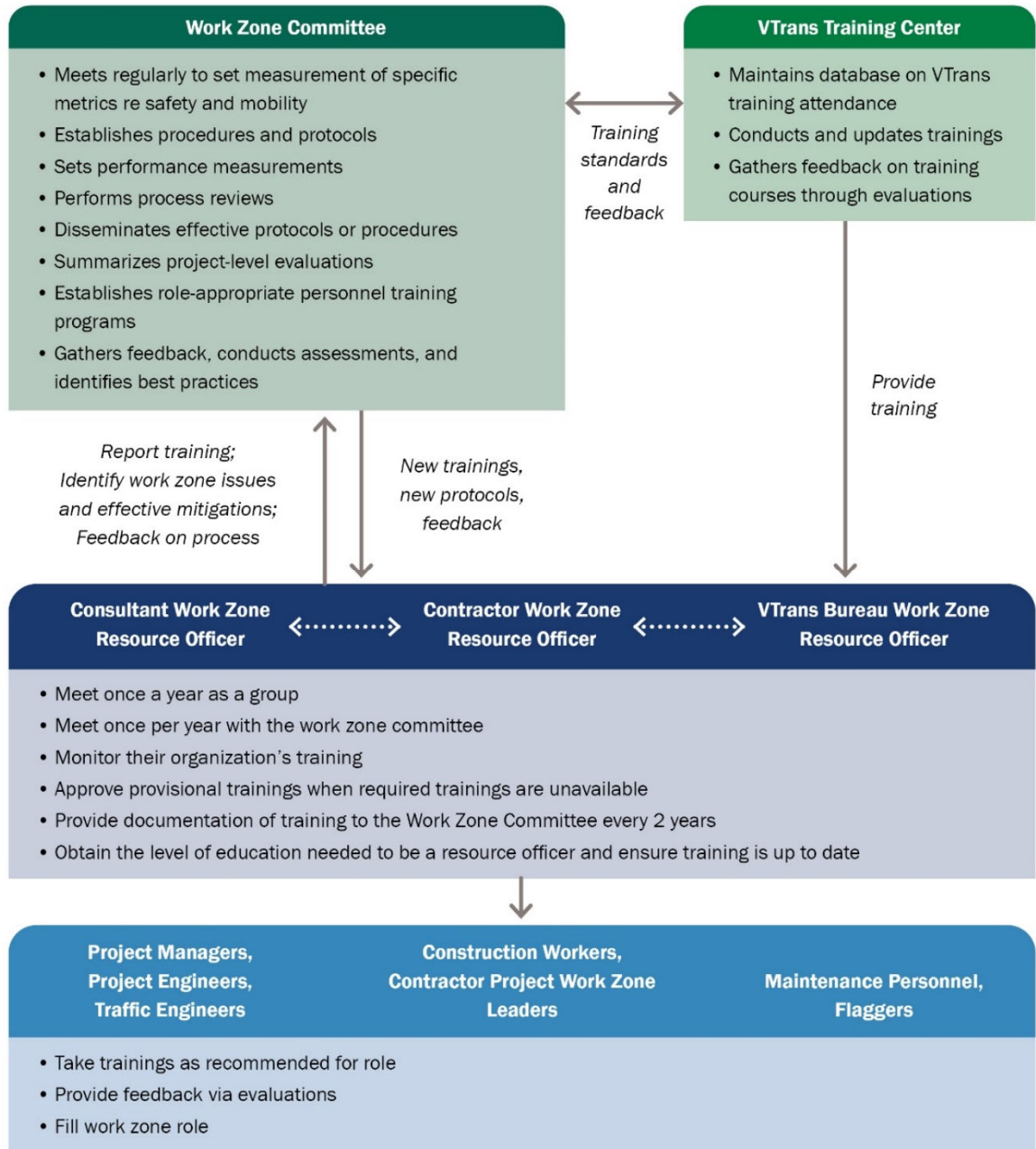

Recommended Courses

Each step in the work zone life cycle requires different training and personnel need to be trained appropriate to the decisions each individual is required to make. The roles and recommended appropriate training are outlined in Table 2 below, and the detailed course descriptions follow. If a course is not available, a WZRO may suggest and provisionally approve a comparable training course. The Work Zone Committee will review available and comparable courses on an annual basis.

Table 2 Work Zone Required Training by Role

Role or Responsibility	Recommended Course(s)	Other Appropriate Course(s)
VTrans Bureau, Contractor, or Consultant Entity Work Zone Resource Officer, Work Zone Safety Engineer	A or B	C, D, E, F, G, H, I, J, K, L
Project Manager, Project Engineer, Resident Engineer	A or B	
Contractor Project Work Zone Leader	A or B; or C	F, K
Traffic Engineer (or who is preparing TTC)	A or B	D, K
Highway Workers (involved in Work Zone setup)	C; or E; or L; or K	B
Highway Workers (not involved in Work Zone setup)	K or M	
Flaggers	F or G or K	
Flagger Trainers	H or I or K	
Law Enforcement	J	

Other appropriate courses are options for expanding technical skills

Highway Workers, per FHWA, include, but are not limited to, personnel of the contractor, subcontractor, DOT, utilities and law enforcement, performing work within the right of way of a transportation facility

Course Descriptions

A—Advanced Work Zone Management and Design (offered by FHWA and NHI or its equivalent offered by others). This course gives participants advanced knowledge of technical and nontechnical aspects of work zone traffic control, including best practices. Each participant receives a copy of the “Advanced Work Zone Management and Design” reference manual and participant workbook. This is a three-day course that the Agency can host.

B—Maintenance of Traffic for Supervisors (offered by AASHTO). This training presents information about the placement of, field maintenance required for, and inspection of traffic control devices. Drafting work zone traffic control plans and flagging are also discussed. This training focuses on the design of traffic control and is offered by the VTTC through the Learning Management System.

C—Traffic Control Supervisor (offered by ATSSA). This course teaches how to read and interpret plans and specifications and implement them in the field. Workshops include real-world examples of designing temporary traffic control setups and recognizing, analyzing, and correcting deficiencies. Course H—Traffic Control Technician by ATSSA is a prerequisite for this course.

D—Work Zone Traffic Impact Analysis (offered by ATSSA). This course introduces participants to the concept of work zone impact analysis as a tool to improve the safety and mobility of highway work zones. It discusses impact analysis fundamentals, approaches, methodologies, and the various tools available to conduct these analyses. Emphasis is given to the Transportation Operation (TO) component of transportation management plans (TMP) and how these tools could be used to in assessing TO strategies.

E—Traffic Control Technician (offered by ATSSA). The one-day Traffic Control Technician course is an introduction to temporary traffic control in work zones for individuals who work in the field installing and removing traffic control devices. This course provide concepts, techniques, and practice exercises in the installation and maintenance of traffic control devices.

F—Flagger Certification Training (offered by ATSSA). This course teaches students standard flagger control references, proper flagging signals procedures, and standard flagger practices for various situations.

G—Flagger Instructor Training (offered by ATSSA). This train-the-trainer course emphasizes skills and techniques for teaching the Flagger Certification Course. Flagger instructors are certified and demonstrate core competencies appropriate to flagger and work zone environments.

H—Traffic Control Technician/Flagger Trainer Training (offered by AGC VT). This two-day course provides an introduction to temporary traffic control in work zones for individuals who work in the field installing and removing traffic control devices. This course prepares participants to train members of their companies to be flaggers.

I—Traffic Control Technician/Flagger Trainer Refresher (offered by AGC VT). This course is a refresher to ensure that the trainer’s skills are kept up to date.

J—Safe and Effective Use of Law Enforcement Personnel in Work Zones (offered by FHWA and NHI). This course provides law enforcement agencies with the practices and procedures to improve traffic safety in work zones. It is delivered as a ½-day classroom training or a two-hour interactive web-based training.

K—VTrans Work Zone Setups and Flagger Training (offered by VTTC). This course provides guidance and training for VTrans maintenance field personnel working in the planning, selection, application, and operation of short-term work zones. The course addresses typical short-term maintenance activities occurring on two-lane rural highways, multilane urban streets, and interstates. It covers the applicable standards for work zone protection contained in the MUTCD, discussing the need for proper application of devices, while addressing liability issues of highway agencies and individuals. Classroom presentations include practical exercises to plan, set up, operate, and remove work zone safety devices. This course covers Part 6 of the MUTCD and will teach students standard flagger control references, proper flagging signals procedures, and standard flagger practices for various situations. Upon successful completion, the student will receive a certification card valid for two years.

L—Traffic Control Technician/Flagger Training. These courses are taught by individuals who have taken H (and I to refresh their skills) and return to conduct these trainings for their organization.

M—Construction Safety:Working Safety in Work Zones-Traffic and Safety (offered by AASHTO). This course is part of the Construction Safety Awareness series and provides an awareness of the hazards of working on or near roadways, especially in poor visibility conditions given the presence of high-speed traffic, construction vehicles and

equipment, and other hazards. The components of temporary traffic control will also be explained.

Assessment and Improvement Procedures (Process Review)

VTrans Regional Construction Engineers will gather closeout reports conducted at the completion of each project and lessons learned from project on-site reviews. They will summarize the closeout reports and provide these to the Work Zone Safety Engineer. The data will be compiled and summarized into an annual evaluation of work zone safety and mobility procedures. The annual evaluation should not only summarize project-level data, but also highlight effective project-level strategies and recommend how these strategies could be more broadly implemented. The Work Zone Safety Engineer will submit a summary of TMP effectiveness and recommendations for improvements to the Work Zone Committee at the end of the construction season based on the work zone documentation provided by the Regional Construction Engineers.

The Work Zone Committee will conduct a biennial Process Review to review progress on work zone safety and mobility and satisfy FHWA Process Review requirements. The Process Review ensures that operational processes are consistent with established procedures, standards, and expectations. This process will include a review of the overall construction season summary from the Work Zone Safety Engineer in addition to project information assembled by the Regional Construction Engineers. As part of the Process Review, the Work Zone Committee may audit particular projects, do a more in-depth crash review, or conduct real-time review of projects with identified work zone concerns.

The Work Zone Committee will evaluate the data to improve work zone processes and procedures. The evaluation should compare the data gathered and summarized in the Process Review against project-level and state-level strategies. By measuring the current year's activities against each strategy, the Committee will develop an annual evaluation of progress toward the policy goals. As part of this evaluation, the Work Zone Committee will develop an action plan to identify patterns and address deficiencies identified statewide and regionally. The actions may result in recommendations to improve progress on strategies, adjust training requirements, or modify the Guidance.

The State Traffic Engineer will document the Process Review and provide it to the Chief Engineer. Findings will be circulated as appropriate to disseminate recommendations for future work zones.

The Work Zone Committee and FHWA representatives should conduct a collaborative review of the biennial process review at a minimum of every five years, with a focus on annual evaluation of progress towards the Policy Goals. Adjustments to the goals and strategies should be considered, as well as any recommendations to update the policy or guidance appropriately. Results of this evaluation will inform updates to the Policy or the Guidance document.



PROJECT-LEVEL PROCEDURES



In addition to state-level procedures, there are a number of procedures required to improve work zone safety and mobility at the project level. Outlined below are the procedures required to determine a project’s level of significance and the scope of the resulting requirements in regards to work zone safety and mobility.

Strategies

VTrans has identified strategies at the project level to help meet each of the Work Zone Safety and Mobility Policy Goals outlined below (see Table 3). The parties responsible for executing and approving the actions associated with each strategy are listed in the Responsibility and Approval columns, respectively. The applicability of each strategy to a particular project is determined by evaluating the project significance; see the Project Significance section below.

Table 3 Work Zone Project-Level Strategies

	Project-Level Strategies	Responsibility	Review/Approval
Safety			
	Develop and/or apply site-appropriate temporary traffic control plans and any necessary traffic related special provisions.	VTrans PM	VTrans PM (design)/ Resident Engineer (construction)
		Contractor PM	
		Other owner PM	
	Follow procedures for on-site monitoring of safety measures and mitigation of safety issues.	VTrans PM	Resident Engineer
		Contractor PM	
		Other owner PM	
	Provide a safe, continuous, and accessible path that is functionally equivalent to the existing pedestrian, bicycle, and/or vehicular facilities.	VTrans PM	VTrans PM (design)/ Resident Engineer (monitoring)
		Contractor PM	
		Other owner PM	
Mobility			
	Follow procedures for identifying potential delays and access limitations in planning and design.	VTrans PM	VTrans PM (design)
		Contractor PM	
		Other owner PM	
	Follow procedures for setting project-appropriate maximum acceptable delay and monitoring on-site delays	VTrans PM	VTrans PM (design)/ Resident Engineer (monitoring)
		Contractor PM	
		Other owner PM	
	Follow procedures for mitigating project-related delays and/or access limitations in implementation.	VTrans PM	Resident Engineer with support from Work Zone Safety Engineer
		Contractor PM	
		Other owner PM	

	Project-Level Strategies	Responsibility	Review/Approval
	Provide a convenient, continuous, and accessible path that is functionally equivalent to the existing pedestrian, bicycle, and/or vehicular facilities.	Contractor PM	VTrans PM (design)/ Resident Engineer (monitoring)
		VTrans PM	
		Other owner PM	
	Provide traveler information to minimize delays and improve mobility.	VTrans PM	VTrans PM (design)/ Resident Engineer (monitoring)
		Contractor PM	
		Other owner PM	
Assessment/Improvement			
	Provide project-level evaluation regarding safety and mobility at the completion of the project.	Contractor PM	Regional Construction Engineer
		VTrans Resident	
		Other owner PM	
Training			
	Ensure all project personnel receive appropriate work zone training.	Bureau Work Zone Resource Officer	V TTC maintains database, review by Work Zone Committee yearly
		Contractor Work Zone Resource Officers	Review by Work Zone Committee yearly
		Consulting Firm Work Zone Resource Officers	Review by Work Zone Committee yearly

Note: Responsible party depends on the role for that particular project. Consultants can act on behalf of VTrans, contractors, or other entities and would align with the responsibility assigned to the party they are representing on the project.

Project Significance

This section provides guidance in determining the appropriate project significance category for construction projects, maintenance operations, and/or other activities within the state highway right-of-way. Although the types of activities, activity duration, and traffic control can vary, any activity in the highway right-of-way may adversely affect safety and mobility. As a result, traffic management strategies must be consistent regardless of what type of activity is taking place. The significance category of a project will determine the required Work Zone Safety and Mobility documentation. This will be based on the complexity of the project and the planning needed for the anticipated safety and mobility impacts.

A significant project is defined by FHWA as a project that alone, or in combination with other concurrent projects, is anticipated to cause sustained work zone impacts that are greater than would normally be expected based on State policy or engineering judgment.

Criteria for Determining Significant Projects

All highway transportation projects must be classified to determine project level of significance according to the Project Significance Criteria (see Table 4). There are four project levels of significance categories with varying levels of safety and mobility complexity. To accurately classify a project, several roadway, location, and project characteristics must be considered; Table 4 and the Project Evaluation Criteria Guidance below provide more detail.

The Project Manager shall identify project significance during the Project Definition process, or as early in the design process as possible. Early identification of significance level allows for appropriate assessment of safety and mobility impacts and evaluation of methods for mitigating possible impacts. The Project Manager may consult with the Program Manager, District Transportation Administrator, or General Manager for appropriate significance category. Once determined, the project significance must be documented in the project file.

The significance category shall be revisited and confirmed by the VTrans Project Manager prior to Preliminary Design and PS&E Plan submissions. As a project develops—and with approval of the VTrans Program Manager, District Transportation Administrator, or General Manager—mitigating factors, such as limiting work to low traffic volume hours, may be used to reduce a project's level of significance. The Project Manager shall document mitigating factors and the resulting level of significance in the TMP checklist; this must be approved in writing by the Program Manager, District Transportation Administrator, or General Manager. The TMP checklist will be completed for all projects, regardless of significance category, but the determination of project significance level determines how you approach the TMP checklist by alerting the Project Manager to the likelihood of the TMP components required.

The Project Manager shall evaluate the project against significance Category A and then work down the chart in Table 4 until the criteria for a significance level are met. For example, if a project meets requirements for both Category B and C, it would be considered a Category B project.

The paragraphs below describe significance levels, including typical project types that fall under each category and the resulting level of effort to address work zone safety and mobility. Table 4 includes more detailed criteria.

Category A Significant Projects are those located on Interstates or other high-volume/high-speed and/or divided facilities or those that are expected to include traffic control such as long-term lane closures, detours, or diversions in the project area for two or more construction seasons. Example projects are bridge replacements or interchange improvements on interstates. Category A projects require the completion of the TMP checklist to determine the scope of potential work zone safety and mobility issues.

These issues will be addressed via components of the TMP: Traffic Operations (TO) and Public Information Plan (PI) documents and consideration as to whether typical applications or site-specific Temporary Traffic Control (TTC) plans are required. For Category A projects, addressing the scoped issues via TO, PI, and TTC plans becomes the TMP package unless mitigation allows for reduction to a Not Significant category. TMPs for

Significant projects also may contain cost estimates, coordination strategies among stakeholders, secondary mitigation strategy(ies), traffic analysis of potential impacts on detour routes, and traffic analysis of the potential impacts of the management strategies. For Significant projects, the PM and project team should meet with Town officials and representatives from emergency services during development of the TMP and document the coordination within the TMP.

With appropriate mitigating strategies and Program Manager, District Transportation Administrator, or General Manager approval, some Category A Significant Projects such as line striping or signage projects may be reduced in significance category.

Category B Significant Projects are determined by such factors as project location, multi-project interaction, impact on other modes, duration of traffic impacts, traffic generators, and network reliability. Compared to a Category A rating, Category B projects typically have lower traffic volumes and involve more than one significance criterion. Category B examples include projects through downtown villages with significant impacts to pedestrians and bicyclists, projects with many driveways introducing friction within a work zone, or locations where multiple projects affect safety and mobility in one high-volume corridor. Category B projects also require the completion of the TMP checklist to determine the scope of work zone safety and mobility issues to be addressed. In addition, for Category B projects, the TMP checklist, TO, TTC, and PI components are all required as part of the TMP package unless mitigation modifies the project to a Not Significant category.

TO, TTC, and PI is driven by the responses to the TMP checklist. These projects typically require extensive public information and project coordination with nearby projects and traffic generators and are more likely to require site-specific TTC. For Significant projects, the PM and project team should meet with Town officials and representatives from emergency services during development of the TMP and document the coordination within the TMP.

Category C projects are not considered Significant projects, however, the TMP checklist is required and will alert the Project Manager to safety and mobility concerns throughout the project life cycle. In addition, TTC plans (VTrans standard drawings, MUTCD typical applications, or site-specific as necessary) will need to be prepared. TO and PI components may need to be included if major issues are identified in the TMP checklist based on other local projects, traffic generators, or network reliability.

Category D projects are not anticipated to require site-specific mobility and safety strategies, however, the TMP checklist is required to document that anticipated lack of impact. These are typically projects along lower-volume roadways with minimal access points, or with very minor impacts to mobility and safety anticipated. These projects usually require standard drawings and/or typical applications for TTC, but may require site specific TTC plans.

Table 4 provides the evaluation criteria for each significance level; further guidance is provided in the section that follows.

This page intentionally left blank.

Table 4 Project Significance Criteria

Project Type (Number of Criteria)	Permanent Posted Speed Limit of Facility	Existing AADT	Multi-Project Interaction	Project Location	Non- Automobile Modes	Duration of Project Traffic Impacts	Level of impact to high-volume or critical traffic generators	Network Reliability	Significance	Resulting Requirements
A—Typically high-volume, high-speed roads (meets 1 or more of these criteria)	≥55 mph	>20,000 interstate or >15,000 state highway				2 or more construction seasons			Significant	TMP checklist to determine required scope for TO, PI, TTC; consider mitigation
B—Complicated areas due to users, locations generators, or other projects (meets 3 or more of these criteria)		>15,000 interstate or >10,000 state highway	One or more other projects in the vicinity are affected by this project’s traffic impacts (or vice versa)	Located within a downtown district or village center that creates additional traffic management challenges	Extensive impact to pedestrian or bicycle facilities with demonstrated demand or transit routes		High Impact	If there is an incident, there is no redundancy in network to ensure mobility	Significant	TMP checklist to determine required scope for TO, PI, TTC; consider mitigation
C—Lower-volume locations with some complications (Meets 2 or more of these criteria)		>10,000 interstate or >5,000 and state highway	One or more other projects in the vicinity are affected by this project’s traffic impacts (or vice versa)	Located within a downtown district or village center that creates additional traffic management challenges	Extensive impact to pedestrian or bicycle facilities with demonstrated demand or transit routes		Medium or High Impact	If there is an incident, there is no redundancy in network to ensure mobility	Not Significant	TMP checklist to determine if any TO, PI, TTC requirements
D—Simpler work zones on lower-volume roadways			Project is isolated or other projects are not likely to affect traffic or safety of this project	Location presents minimal traffic management challenges					Not Significant	TMP checklist to document if no TO, PI, TTC requirements

This page intentionally left blank.

Project Evaluation Criteria Guidance

Permanent Posted Speed Limit of Facility: This is the permanent posted speed limit of the facility, not including any speed limit reductions implemented during construction.

Existing Average Annual Daily Traffic (AADT): Vermont traffic volumes are updated annually to the VTrans website and provided at the following link: <https://vtrans.vermont.gov/operations/technical-services/traffic>. Additional traffic count data is available at: VTrans Traffic Data Management System.

Multi-Project Interaction: This criterion requires the PM to consider other state and local projects that may be underway or proposed in the area. This is crucial as each project may involve impacts like detours whether planned or that occur as a result of self-diverting to avoid construction, necessitating retiming of signals and additional maintenance of local bypass areas. The cumulative effect of delays caused by multiple projects may also have an impact. Refer to the [VTransparency Project Map](#) and explore local sources. Check back at major milestones of the project, as schedules evolve over time.

Project Location: This criterion requires the PM to consider the context of the project. Is the project located in the downtown or the village? Will the project have considerable interaction with access points and alternative modes of transportation? Engineering judgement will be given to the size of the village or downtown and the project's location within the village or downtown. For guidance, at a minimum, designated downtowns and villages are included here:

<http://maps.vermont.gov/ACCD/PlanningAtlas/index.html?viewer=PlanningAtlas>

Non-Automobile Modes: This criterion requires the PM to consider areas of considerable pedestrian or bicycle mobility impact. Sidewalk projects that involve a detour to cross pedestrians safely to a sidewalk across the street and back may not be considered significant, but lengthy detours on a heavy pedestrian route to a school would be. Similarly, a shared use path that is being reconstructed may divert bicyclists on road to use a wide shoulder for a short distance during construction and may not be considered significant, but lengthy diversions to a vehicle and bicycle shared lane may be. VTrans Bicycle Corridor Priority Map is located here:

http://www.aot.state.vt.us/documents/bikeplan/VTrans_Bicycle_Corridor_Priority_Large_Map_201603_Final.pdf

Duration of Project Traffic Impacts: This evaluation criterion considers the multiyear project that requires traffic control in a single work zone area over multiple construction seasons. Projects that are multiyear projects but constantly change locations (e.g., line striping, sign installation) are not included.

Level of Impact to High-Volume or Critical Traffic Generators: This criterion requires the PM to be aware of sensitive traffic generators in the area (e.g., emergency services, hospitals, schools) as well as significant traffic generators (e.g., traffic impacts of a large manufacturer at shift change). These factors must be considered for a Significant project.

Network Reliability: This column requires the PM to consider whether closure, alternating traffic, or considerable delay on the roadway would impact the reliability of emergency vehicles (police, fire, rescue, and ambulance) to reach each side of a project. Consideration of traffic associated with major employers, key commuting routes, school traffic, delivery services such as fuel, or postal service is also important. Impacts for wide-load restrictions or farm equipment during seasonal harvest periods should also be considered.

Potential TMP Components

A transportation management plan (TMP) summarizes the strategies or methodologies that will be implemented to ensure safe and mobile work zones within transportation projects. The project significance will dictate the required components of the TMP and how those components should be documented. The components of the TMP are:

- › **Temporary Traffic Control (TTC):** TTC describes temporary traffic control measures to be used for moving roadway users through a work zone or an incident area. The TTC plays a vital role in providing safe and efficient roadway user flow and highway worker safety when a work zone, incident, or other event temporarily disrupts standard operations. The TTC shall be consistent with the provisions of the FHWA Manual for Uniform Traffic Control Devices (MUTCD), AASHTO Policy on Geometric Design of Highways and Streets, AASHTO Roadside Design Guide, and State standards and specifications. When a TTC plan is not provided as a part of the bid documents, the TTC plan needs are documented as part of the TMP checklist, with details provided in traffic control notes, and/or traffic control special provisions to provide the contractor with the required guidance to prepare the TTC plan.
- › **Transportation Operations (TO):** The TO identifies strategies and assigns responsibility for mitigating impacts of the work zone on transportation system operation within the work zone impact area. The work zone impact area consists of the immediate work zone, the surrounding roadways, proposed detour routes, and affected communities. The TO typically takes the form of a narrative describing the TO mitigation strategies to be employed. The TO may be documented as a brief description in the TMP Checklist for Not Significant projects for simple approaches, or a separate narrative to detail possible range of TO mitigation strategies based on the scope outlined in the TMP Checklist for Significant Projects or more complex approaches. The TO is used during the design phase for better project planning and the identified strategies are then communicated to the contractor via the TMP Checklist.
- › **Public Information (PI):** The PI includes communication strategies to inform the general public and community stakeholders of work zone impacts and the changing conditions of the project. The audience for this information may include road users, area residences and businesses, and other public entities. The PI is used to better communicate project information to the public during the design and construction phases. The TMP Checklist will raise potential work zone safety and mobility concerns and mitigation that may need to be communicated to the public. For a project with more significant issues, a separate memorandum would be appropriate.

TMP Development Process

After determining project significance level, the Project Manager will determine how the project will maintain safety and mobility for traffic of all modes (vehicular, pedestrian, and bicycle) during construction. The Project Manager is responsible for completing the TMP Checklist, below, for all projects during project definition, or as early in the project development process as possible, to determine safety and mobility concerns. The Project Manager shall review and revise the checklist to provide updated responses at Preliminary Design and PS&E milestones based on the project and modifications to work zone safety and mobility. If significant changes in the scope occur during project development, the Project Manager should revisit this checklist to confirm or update the TMP requirements. If a change to the project significance level is justified, the Program Manager, District Transportation Administrator, or General Manager must approve the change and document it in the project file.

For projects classified as Significant, the TMP Checklist acts as a scoping document for the TO aspect of the TMP. The Program Manager, District Transportation Administrator, or General Manager may identify the projects that the Agency considers Most Significant. Those projects will require the TO, PI, and TTC plan components to be completed. The TO and PI components may be summarized in separate documentation for the Agency's most Significant projects. Although TO and PI components are not included in the bid documents, they should be shared with the contractor at or before the preconstruction meeting to ensure that the planned strategies are incorporated during construction.

If the project is classified as Not Significant, the TMP checklist will identify items that need special attention as the project moves through design and construction. PMs should provide a brief narrative regarding issues that are complicated or require further explanation beyond the checklist criteria. The checklist, and brief narrative if required, in combination with required typical applications, standard drawings, or site-specific TTC plans will serve as the TMP for the project.

TMP Checklist Instructions

For each item in the TMP Checklist, respond Yes, No, Possibly, or Not Applicable. For Not Significant Projects, provide comments for responses requiring additional explanation on this form; for Significant Projects, provide additional TMP documentation if adequate room is not available on the form. All responses checked Possibly require an explanation. The TMP Checklist is provided below and in the Appendix as a standalone document.

TMP CHECKLIST

Purpose: To make a preliminary determination of whether the following issues are present or should be considered during project development through a more detailed TMP.

Initial Project Significance Level (as determined in Table 4): _____

Project Manager during Project Definition:

Name: _____ Date: _____

Modified or Approved by (Project Manager at Preliminary Design for Significant Projects):

Name: _____ Date: _____

Modified or Approved by (Project Manager at PS&E for Significant Projects):

Name: _____ Date: _____

Project Description (Location, Activity, Anticipated Duration):

	Yes	No	Poss	N/A	Comments
1. Does the project require a long-term (greater than 3 days) ¹ lane or roadway/bridge closure?	<input type="checkbox"/>	<input type="checkbox"/>	<input type="checkbox"/>	<input type="checkbox"/>	
2. Are there any restrictions or considerations regarding construction timeframes due to traffic concerns (e.g., time of day, site specific time of year limits)?	<input type="checkbox"/>	<input type="checkbox"/>	<input type="checkbox"/>	<input type="checkbox"/>	
3. Can typical applications for traffic control be used? Are there any limitations to when typical applications can be used (time of year, times, days)?	<input type="checkbox"/>	<input type="checkbox"/>	<input type="checkbox"/>	<input type="checkbox"/>	
4. Is there a sidewalk, pedestrian/bicycle lane, path, trail, or access that needs to be maintained during construction?	<input type="checkbox"/>	<input type="checkbox"/>	<input type="checkbox"/>	<input type="checkbox"/>	
5. Is a speed reduction proposed (consistent with state guidance)?	<input type="checkbox"/>	<input type="checkbox"/>	<input type="checkbox"/>	<input type="checkbox"/>	
6. Will temporary roadways or additional width be needed on culverts, bridges, or shoulders to maintain traffic?	<input type="checkbox"/>	<input type="checkbox"/>	<input type="checkbox"/>	<input type="checkbox"/>	
7. Will construction impact access to businesses?	<input type="checkbox"/>	<input type="checkbox"/>	<input type="checkbox"/>	<input type="checkbox"/>	
8. Are there other projects (utility, district maintenance, construction, municipal) in the area that should be coordinated or avoided?	<input type="checkbox"/>	<input type="checkbox"/>	<input type="checkbox"/>	<input type="checkbox"/>	

	Yes	No	Poss	N/A	Comments
9. Will/Can the traffic be reasonably detoured? If no or N/A, proceed to #10. If yes or possibly:	<input type="checkbox"/>	<input type="checkbox"/>	<input type="checkbox"/>	<input type="checkbox"/>	
a. Is the detour route roadway type equivalent to closed roadway?	<input type="checkbox"/>	<input type="checkbox"/>	<input type="checkbox"/>	<input type="checkbox"/>	
b. Is the local alternate detour route in good condition?	<input type="checkbox"/>	<input type="checkbox"/>	<input type="checkbox"/>	<input type="checkbox"/>	
c. Will the detour route have a detrimental impact on emergency vehicles, school buses, or other sensitive traffic?	<input type="checkbox"/>	<input type="checkbox"/>	<input type="checkbox"/>	<input type="checkbox"/>	
d. Are there load limit restrictions on the detour?	<input type="checkbox"/>	<input type="checkbox"/>	<input type="checkbox"/>	<input type="checkbox"/>	
e. Are there bridge/culvert width or height restrictions on the detour?	<input type="checkbox"/>	<input type="checkbox"/>	<input type="checkbox"/>	<input type="checkbox"/>	
f. Are modifications needed at intersections on detour/alternate routes?	<input type="checkbox"/>	<input type="checkbox"/>	<input type="checkbox"/>	<input type="checkbox"/>	
10. Will traffic signal timing need to be adjusted for the project (with or without a detour)?	<input type="checkbox"/>	<input type="checkbox"/>	<input type="checkbox"/>	<input type="checkbox"/>	
11. Are there truck facilities or routes that would be impacted by the project or by a detour (turning radii, weight restrictions, etc.)?	<input type="checkbox"/>	<input type="checkbox"/>	<input type="checkbox"/>	<input type="checkbox"/>	
12. Are there special events or traffic generators (schools and bus routes, large employers, hospitals) that may be affected by the project and/or detour?	<input type="checkbox"/>	<input type="checkbox"/>	<input type="checkbox"/>	<input type="checkbox"/>	
13. Will the emergency vehicle routing, mail delivery, school bus routes, or trash services be interrupted by the project (with or without a detour)?	<input type="checkbox"/>	<input type="checkbox"/>	<input type="checkbox"/>	<input type="checkbox"/>	
14. Are there specific stakeholders to engage regarding the work zone impacts?	<input type="checkbox"/>	<input type="checkbox"/>	<input type="checkbox"/>	<input type="checkbox"/>	
15. Does the project occur within a high crash location?	<input type="checkbox"/>	<input type="checkbox"/>	<input type="checkbox"/>	<input type="checkbox"/>	
16. Are there other maintenance of traffic issues to consider? Specify.	<input type="checkbox"/>	<input type="checkbox"/>	<input type="checkbox"/>	<input type="checkbox"/>	

1. MUTCD definition of long-term work is occupying a location more than 3 days.

Additional Narrative for Not Significant Projects with issues identified above:

As outlined above, the checklist becomes part of the TMP for a project either by dictating the scope for additional investigations (for Significant Projects) or by becoming the TO component of the TMP (for Not Significant Projects). For Significant Projects, the Project Manager will prepare additional documentation of traffic operations and public information as necessary in response to the scope identified in the TMP checklist. In addition, temporary traffic control plans (either standard drawings, typical applications, or site-specific TTCs) will be developed. For Not Significant Projects, traffic operations or public information items of concern will be detailed in the TMP checklist comment section—using additional space if needed—and relevant standard drawings or typical applications referred to and/or TTC plans prepared as required. The TMP Checklist and supporting documentation shall be included in the Project Bid documents. Expected mitigating strategies that are not identified or otherwise outlined in the TMP Checklist shall be specified in the Traffic Control Notes or Traffic Special Provisions for the project.

TTC Development

There are generally three tracks by which the TTC will be developed. These will dictate the procedures taken prior to construction.

- › If the TTC is composed of standard drawings or typical applications without requiring site-specific modification, the applicable standard drawings or typical applications may be identified in the TMP Checklist and the TMP Checklist included in the bid documents.
- › If the Agency, or a consultant working on the Agency's behalf, designs a site-specific TTC, the TMP Checklist and TTC will be included in the bid documents. The contractor shall either agree to implement the TTC as prescribed or submit an alternative plan, per the Standard Specifications for Construction. An alternate plan submission would be subject to a conformance review prior to implementation, as stipulated in the Standard Specifications for Construction.
- › If a site-specific TTC is to be designed by the contractor, the elements scoped in the TMP checklist shall be sufficiently outlined in the TMP Checklist and any Traffic Control Notes and/or Special Provisions for the contractor to develop the TTC. This may include site-specific modifications to standard drawings or typical applications identified in the TMP Checklist. The site-specific TTC is subject to the Construction Drawing submittal procedures stipulated in the Standard Specifications for Construction. VTrans would review to verify TTC conformance with the stipulations of the TMP Checklist and/or any Traffic Control Notes and Traffic Control Special Provisions.

Figure 2 TMP Development Process

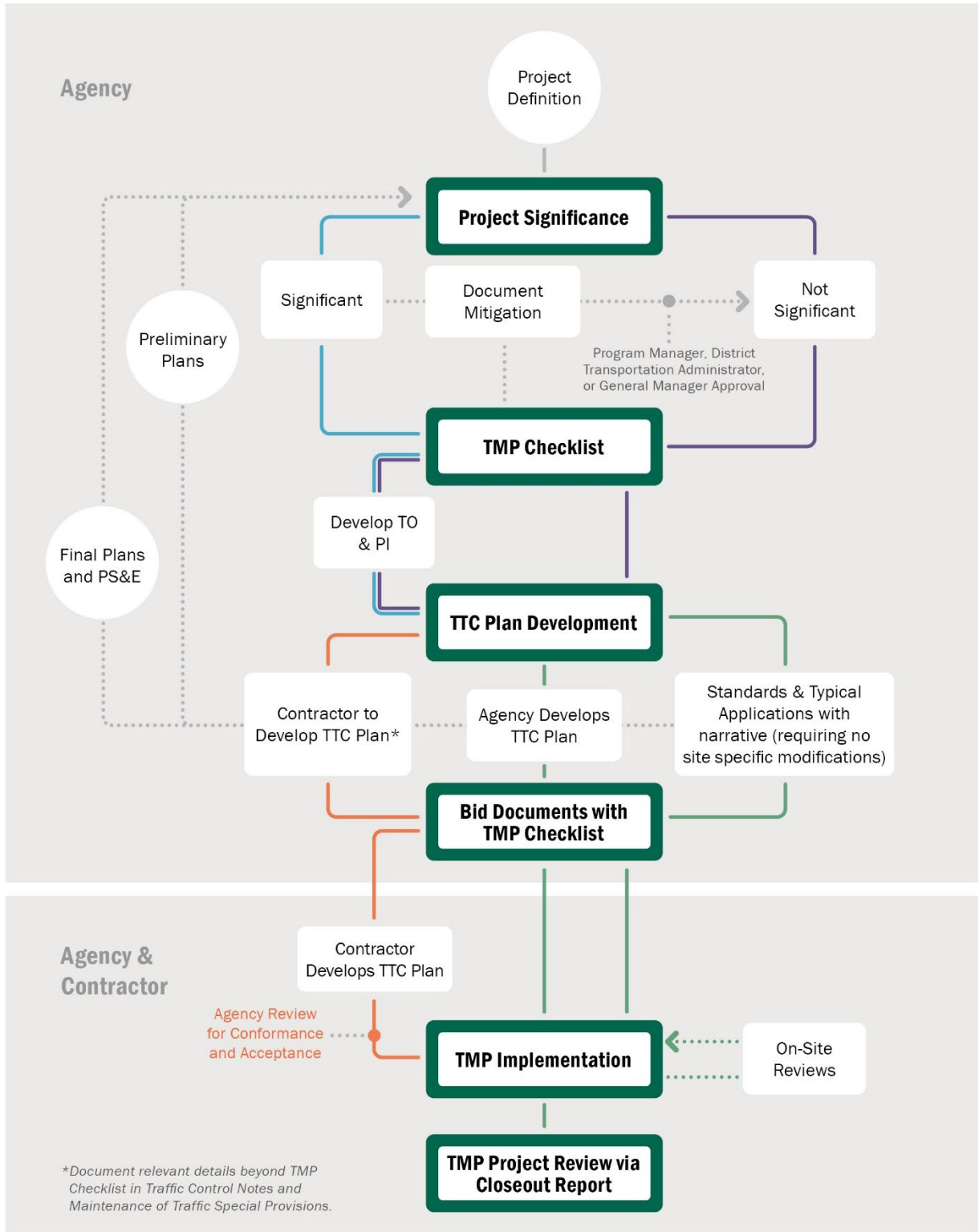

TMP Implementation and Feedback Processes

To ensure all parties are informed of the approved strategies and implementation plan, the final TMP Checklist and any final detailed TMP components shall be discussed at the preconstruction conference. For any Significant project, appropriate coordinated on-site review intervals (e.g., weekly or monthly) or project milestones (e.g., prior to start of construction or new phase of multiphase project) must be identified and agreed upon during preconstruction conference and documented by the Project Manager prior to start of construction.

The Resident Engineer is responsible for verifying that traffic control devices and measures are in place consistent with the TMP checklist, special provisions, and TTC and documenting the routine review in the Daily Work Report per the construction and inspection stipulations in the Construction Manual. The Contractor and Resident Engineer may modify the work zone in ways consistent with the TMP checklist, traffic special provisions, and TTC. The Resident Engineer will document those changes in the Daily Work Report and the Contractor will prepare modified TTC plans as required.

Beyond the daily effectiveness review, coordinated on-site reviews may be conducted periodically throughout the project. For Significant projects, coordinated on-site reviews shall be conducted regularly based on the interval or project milestones decided upon during preconstruction conference. Additionally, for Significant projects, coordinated on-site reviews may be made at the request of the Resident Engineer. Present parties for any coordinated on-site review may include the Contractor Project Manager, Project Resident Engineer, and VTrans Project Manager as appropriate. Additional support for coordinated on-site reviews from other trained personnel, like the Work Zone Safety Engineer, or field audits may be requested as needed. Any modifications agreed to during any coordinated on-site review shall be documented by the Resident Engineer in the Daily Work Report.

At the completion of the project, the Resident Engineer shall complete a project review using the Closeout Report and submit the Closeout Report to the Regional Construction Engineer and ultimately to the Work Zone Safety Engineer and Project Manager for review. The Closeout Report shall be filed with the Regional Construction Engineer within 30 days of the project final inspection.

Project reviews should consider the items in the TMP Checklist, TTC, and any safety and mobility considerations or strategies employed for the project. The project review should assess the project against the project-level strategies from Table 3. The project review should also make note of any modifications made to the TMP and innovations/ best practices employed in the TMP, whether resulting from a coordinated on-site review or other means of identifying an issue. If applicable, the project review should document any Traffic Operations or Public Information considerations required of the project to mitigate unforeseen circumstances (e.g., unanticipated special events, unusual peak volumes, unexpected traffic generators).

All Closeout Reports submitted by December 31 for that year shall be compiled and analyzed for trends by the Work Zone Safety Engineer. The analysis shall be submitted to the Work Zone Committee by February 28 to identify areas for improvement.

2

Work Zone Safety and Mobility Strategies

INTRODUCTION

This chapter provides information on the temporary traffic control devices, transportation operation and public outreach strategies to increase the safety and mobility in and around work zones. This section was drafted in response to the work zone regulations in 23 CFR 630, Subpart K, published by the Federal Highway Administration (FHWA).

These three sections contain information designed to control and minimize worker exposure to traffic hazards and to increase road user safety and mobility. Additional guidance for preparing site specific traffic control plans can be found in Part 6 of the Manual on Uniform Traffic Control Devices (MUTCD) and in current VTrans Engineering Instructions.

The first section of this chapter contains quick look up tables of all strategies in the three categories and then is followed by information on each strategy.

WORK ZONE MANAGEMENT STRATEGIES

1. Temporary Traffic Control (TTC)

A. Demand Management Strategies	B. Traffic Control Devices	C. Innovative or Accelerated Construction Techniques
<ol style="list-style-type: none"> 1. Construction phasing/staging 2. Lane shift/closures 3. Full roadway closures 4. Median crossovers 5. One- or two-way controlled operations 6. Reversible lanes 7. Ramp closures/relocation 8. Freeway-to-freeway interchange closures 9. Night work 10. Weekend work 11. Work hour restrictions for peak travel 12. Pedestrian/bicycle access improvements 13. Business access improvements 14. Off-site detours/use of alternate routes 15. Shoulder closures for worker safety 	<ol style="list-style-type: none"> 1. Temporary signs 2. Arrow boards 3. Changeable message signs 4. Longitudinal and lateral buffer space or barricades 5. Channelizing devices 6. Channelizing device spacing reduction 7. Temporary pavement markings 8. Flaggers and uniformed traffic control officers 9. Automated flagger assistant devices (AFADs) 10. Work zone speed management 11. Pace or pilot vehicle 12. Temporary traffic signals 13. Lighting devices 	<ol style="list-style-type: none"> 1. Prefabricated/precast elements 2. Rapid cure materials 3. 'Slide' bridge installation 4. Geotech abutment solutions 5. Full roadway closures 6. Round-the-clock work
D. Project Coordination Strategies	E. Innovative Contracting Strategies	F. Construction Consideration
<ol style="list-style-type: none"> 1. Other area projects 2. Utilities 3. Right-of-way 4. Other transportation infrastructure 	<ol style="list-style-type: none"> 1. Construction Manager/General Contractor 2. Design build 3. A+B bidding 4. Incentive/disincentive clause 5. Lane rental 6. Performance specifications 	<ol style="list-style-type: none"> 1. Switchover between construction phases 2. Winter shut-down

2. Transportation Operation (TO)

A. Demand Management Strategies	B. Corridor/Network Management Strategies	C. Work Zone Safety Management Strategies
<ol style="list-style-type: none"> 1. Transit service improvements 2. Transit incentives 3. Shuttle services 4. Ridesharing/carpooling incentives 5. Park-and-ride promotions 6. Telecommuting 7. Pedestrian and bicycling accommodations 	<ol style="list-style-type: none"> 1. Signal timing/coordination improvements 2. Temporary traffic signals 3. Roadway/intersection improvements 4. Bus turnouts 5. Emergency pulloffs 6. Turn restrictions 7. Parking restrictions 8. Truck/heavy vehicle restrictions 9. Reversible lanes 10. Dynamic lane closure system 11. Railroad crossings traffic control 12. Coordination with adjacent construction site(s) and/or detours 13. Rolling road blocks 	<ol style="list-style-type: none"> 1. Speed limit reduction/ speed limits based on condition 2. Temporary traffic signals 3. Temporary traffic or positive barrier 4. Traffic screens 5. Mile post markers 6. Movable traffic barrier systems 7. Crash cushions 8. Truck mounted attenuators 9. Temporary rumble strips 10. Intrusion alarms 11. Warning lights 12. Automated flagger assistance devices (AFADs) 13. Project task force/committee 14. Construction safety/inspectors 15. Road safety audits 16. TMP monitor/inspection team 17. Team meetings 18. Project on-site safety training 19. Windshield survey
D. Incident Management and Enforcement Strategies	E. ITS Implementation	F. ITS Performance Monitoring Strategies
<ol style="list-style-type: none"> 1. Media coordination 2. Local detour routes 3. Tow/freeway service patrol 4. Contract support for incident management 5. Incident/emergency management coordinator 6. Incident/emergency response plan 7. Dedicated (paid) police enforcement 8. Cooperative police enforcement 	<ol style="list-style-type: none"> 1. ITS for traffic monitoring/management 2. Transportation management center (TMC) 3. Helicopter and drones for aerial surveillance 	<ol style="list-style-type: none"> 1. Public Surveys 2. Surveillance: traffic queues/delays 3. Surveillance: travel times

3. Public Information

A. Outreach Preparation	B. Public Engagement Strategies	C. Motorist Information Strategies
<ol style="list-style-type: none"> 1. Determine appropriate size/nature of campaign 2. Identify resources 3. Identify partners 4. Identify target audiences 5. Develop campaign messages 6. Determine communication strategies 7. Determine when to communicate 8. Evaluate effectiveness 	<ol style="list-style-type: none"> 1. Brochure and mailers 2. Press release/media alerts 3. Project information center 4. Telephone hotline 5. Planned lane closure website 6. Project website 7. Public meetings/hearings, workshops 8. Community task forces 9. Coordination with media, schools, businesses, emergency services 10. Email/listserv alerts 11. Work zone safety highway signs 12. Social media 13. Educational videos 	<ol style="list-style-type: none"> 1. Changeable message signs 2. Temporary motorist signs 3. Dynamic speed message sign 4. Project information hotline 5. Traffic ratio 6. Highway advisory radio (HAR) 7. Extinguishable signs 8. Highway information network (wed-based) 9. New England Compass Traveler information systems (511) 10. Freight travel information

1) Temporary Traffic Control (TTC)

Temporary traffic control (TTC) strategies, devices, and contracting/construction techniques and coordination are used to facilitate traffic flow and safety through and around work zones. In some cases, specific TTC strategies have been envisioned during planning and design and identified in the TTC plans and/or TMP checklist. In other cases, the Contractor develops the TTC strategies during the construction phase in a way that is consistent with the TMP checklist.

When developing and implementing TTC plans for projects, maintain preexisting traffic control devices at an equivalent or better level than existed prior to project implementation. TTC strategies include:

- 1.A) Control Strategies
- 1.B) Traffic Control Devices
- 1.C) Innovative or Accelerated Construction Techniques
- 1.D) Project Coordination Strategies
- 1.E) Innovative Contracting Techniques
- 1.F) Construction Considerations

1.A) Control Strategies

This category includes traffic control approaches to accommodate road users within the work zone or the adjoining corridor efficiently and safely, while providing adequate access to the

roadway for construction, maintenance, or utility work. These strategies should be evaluated in advance and indicated on the TMP checklist and/or TTC plans

1. **Construction phasing/staging.** Construction phasing typically refers to how the contractor will position the equipment and materials. Phasing refers to the sequencing of a project, completing portions of the project one part at a time. Use operationally sensitive phasing to minimize the impacts of a work zone on traffic throughout the project.
2. **Lane shift/closures.** Closure or shifting of a lane may be intermittent, off-peak, nights, or weekends for a single project phase or continuous for the duration of the project. This strategy involves multiple approaches, including:
 - a. Reduced shoulder width to maintain number of lanes.
 - b. Shoulder closures to provide worker safety.
 - c. Lane shift to shoulder/median/parking lane to maintain number of lanes.

Consider this when:

- a. Construction could adversely affect adjacent travel lane, such as ledge blasting, or slow heavy construction vehicle traffic moving in and out of work area.
- b. Construction can be accelerated, or work quality can be improved by closing one barrel. When lane closures are being considered, the length of the closure should be limited to the space required to safely construct the work. The table below provides some guidance on maximum length of closure based on traffic volumes.

For Work Zones on Two Lane Highways with One Lane Open for Traffic

Length of Closure	Max. DHV	Max. ADT
2,500 ft	500	4,000
1,500 ft	1,000	7,500
1,000 ft	1,500	11,500

The above values are based on:

- Two phase operation (no intervening intersections) 50-50 directional split.
- 25 mph avg. speed through work zone $v/c \leq 1.0$
- ADT’s may be exceeded if flagging operations cease during peak hours of traffic (work during hours below DHV volumes).

Definitions:

- **Partial detour.** One direction of traffic is maintained on alignment, but the other is detoured. Or, a particular type of traffic is detoured (i.e. trucks) while other traffic is maintained.
- **Full detour/roadway closure.** Full road closure with traffic maintained off-alignment. Detour may consist of temporary roadway or signed detour on existing highways. Diversions – two way traffic is maintained on alignment but because of real or perceived capacity constraints, substantial numbers of drivers can be expected to seek alternate routes not officially signed as detours.

3. **Full roadway closures.** This strategy involves complete closure of the roadway for various time periods to minimize project duration and improve worker safety by reducing traffic conflicts. Full closures may be brief (e.g., intermittent, off-peak), short term (e.g., night, weekend), or long term (e.g., continuous for the duration of the project). Consider this when:
 - a. Viable alternate routes are available, and full road closure will accelerate construction.
 - b. Construction is only feasible with the roadway closed.
 - c. Emergency vehicle access can be accommodated in another manner.

When and What to Consider:

- Capacity, condition and safety of detours/alternate routes must be considered.
- Off-site improvements, especially at intersections, may be necessary to accommodate additional traffic. This may include temporary signalization, changes in signal timings, paving or temporary widening, signing/pavement markings improvements, brush cutting to improve sight distance at intersections.
- Truck traffic and truck turning characteristics must be considered.
- Legal load restrictions on town highways or bridges may be lower than state highway limits. Town highways may require upgrades to accommodate increased truck traffic if detour is allowed by town.
- Separate truck detours may be considered.
- Bicycle and pedestrian access must be considered.
- Long detours are not acceptable for these modes of traffic.
- Bicycles and pedestrians shall not be detoured onto limited access highways.
- Detour route for these modes does not have to be the same as for vehicular traffic, if signed separately.
- Road surface conditions may need to be upgraded.
 - Access to businesses (including directional signing) and residences must be considered.
 - Emergency vehicle access must be considered.
 - Detour route shall be adequately signed
 - For town highway bridge projects, town should designate detour route prior to ROW process commencing, and the designated detour route should be included in the project plans.

A public relations campaign is essential for off-site detours. See Section 2.B for Public Awareness Strategies.

4. **Median crossovers.** Median crossovers should be considered when construction could adversely affect adjacent travel lane, such as ledge blasting and/or construction can be accelerated or work quality can be improved by closing one barrel. The capacity of the remaining barrel must be considered. AADT should be less than 25,000 (DHV<3000) unless an engineering study shows that capacity is sufficient. Crossovers should avoid interchange areas and be located to maximize sight distance for merging. Crossovers must be designed carefully to minimize rollover potential for large trucks (see VTrans Standards).

5. **One- or two-way controlled operations.** This strategy involves using one lane for both directions of traffic, allowing work activities to occur in the closed lane.
6. **Reversible lanes,** also known as variable lanes or contra-flow lane, involves sharing lane (s) of travel to accommodate peak-period traffic flow. The direction of travel in the shared lane varies by time of day or day of week.
7. **Ramp closures/relocation.** This strategy involves closing one or more ramps in or near the work zone for specific time periods or construction phases to allow work access or improve traffic flow on the mainline.

Consider this when:

- a. Construction on ramp will not allow adequate width (15 ft) to be maintained. (Temporary ramp widening may be a feasible alternative to ramp closure. For short durations, lesser widths may be acceptable; notice of the roadway restriction must be sent to DMV.)
- b. Mainline lane closures are close to ramps and adequate distances for safe merging cannot be obtained.
- c. Night work when ramp volumes are very low.

A public relations campaign is essential for ramp closures. See Section 3 for Public Outreach and Motorist Information Strategies.

8. **Freeway-to-freeway interchange closures.** These closures involve closing one or more freeway- to-freeway interchange connectors over a period of time.
9. **Night work.** Work that is performed from the end of evening peak period to beginning of morning peak period to minimize work zone impacts on traffic and adjacent businesses.

Consider this for:

- a. High volume non-residential roads, especially with substantial daytime business traffic.
- b. When capacity is constrained, but detours are not a viable option.

Lighting requirements, the risks of higher travel speeds, and the potential for compromised drivers (drowsy, impaired) should be considered and the results documented on a TTC plan specifically for night work. Local ordinances may prevent night work and should be checked before proceeding with this strategy.

10. **Weekend work.** This strategy restricts individual phases to weekend periods after Friday afternoon peak period to the beginning of the Monday morning peak period. Consider imposing this type of constraint near schools or areas substantial daytime business traffic.
11. **Work-hour restrictions for peak travel.** This strategy restricts work hours so that work impacting traffic does not occur during periods of peak travel demand and congestion (e.g., peak, holidays, special events).
12. **Pedestrian/bicycle access improvements.** Alternate facilities for bicyclists and pedestrians (including those with disabilities, in accordance with the Americans with Disabilities Act of 1990) are provided in places where the work zone impacts their accessibility.

13. **Business access improvements.** Signage or information directing motorists to the business(es) and/or relocating access points is included to maintain adequate access.
14. **Off-site detours/use of alternate routes.** This strategy involves rerouting some or all traffic off the roadway under construction and to other roadways.
15. **Shoulder closures for worker safety.** This strategy can provide increased safety when roadway workers are working in the clear zone (e.g. sign installation, maintenance activities).

1.B) Traffic Control Devices

The MUTCD provides standards, guidelines, and other information pertaining to installing, maintaining, and operating traffic control devices on streets and highways. Part 6 of the MUTCD, “Temporary Traffic Control,” addresses safety and mobility issues in work zones. It applies to all types of highway work from major construction on high-volume freeways to minor maintenance on residential streets and everything in between.

1. **Temporary signs.** Several types of temporary signs provide information to road users to enable safe efficient travel through the work zone or detour. Temporary signs are used in nearly all work zones and are an essential and integral part of temporary traffic control. Types of temporary signs are described in detail in the MUTCD and include:
 - a. *Warning.* These signs give notice to road users of a situation that may not be readily apparent (e.g., speed reductions and road or lane narrows).
 - b. *Regulatory.* These signs provide notice to road users of traffic laws or regulations through the work zone (e.g., speed limits, fine notices, parking restrictions or road closed).
 - c. *Guide/information.* Advance signing and signing in and around the work zone area notify the public of the work zone and/or offer options for alternative routes. Signs may include dates and/or locations of construction and/or closures. Detour signs direct motorists onto detour routes, through the detour, and back to the route from which they were diverted. Advance notice is required so that motorists have time to choose an alternate route.
2. **Arrow boards.** Arrow boards, also referred to as arrow panels, are defined in the MUTCD, and operate in flashing or sequential mode and are intended to aid motorists as they navigate and merge through and around the work zone. Consider using this for merging conditions. If used on two-lane roadways, these devices should only be used in caution mode only.
3. **Changeable message signs (CMS),** both fixed and portable, are highly effective in conveying work zone information to drivers, especially when that information is subject to frequent changes or addresses a short-term or current situation or a condition within the work zone. These devices are described in detail in the MUTCD and help drivers avoid conflicts and potential crashes as they travel through the work zone. Consider these when:
 - a. Drivers require notice of the date or time of upcoming construction activities or traffic pattern changes, which may lead to them seeking alternative routes or changing travel plans. Messages should be updated periodically to describe current work activity so that the CMS continues to command motorists’ attention.

- b. When long-term work zones change traffic control phases and traffic pattern has changed.
- c. When additional directional guidance is required (e.g., using a different exit for a town).
- 4. **Longitudinal and lateral buffer space or barricades.** The buffer space is a lateral and/or longitudinal area that separates road user flow from the work space or roadside hazards, and might provide some recovery space for an errant vehicle. Neither work activity nor storage of equipment, vehicles, or material should occur within a buffer space. The width of a lateral buffer space should be determined by engineering judgment.
- 5. **Channelizing devices.** These are defined in the MUTCD and used to define the intended travel path through the work zone and delineate potential work zone hazards. The devices include traffic cones, drums, barricades, tubular markers, vertical panels, or temporary concrete barriers, and provide traffic control through the work zone.
- 6. **Channelizing device spacing reduction.** The maximum allowable spacing between cones, tubular markers, vertical panels, drums, and barricades is a distance in feet equal to 1.0 times the speed limit in mph when used for taper channelization, and a distance in feet equal to 2.0 times the speed limit in mph when used for tangent channelization. Spacing should be reduced as needed. Consider this when:
 - a. High volume traffic near workers
 - b. Cones are at risk of blowing over
 - c. On curves
 - d. Additional guidance is needed for drivers to safely negotiate work zone
 - e. Using channelizing devices for pedestrian pathways
- 7. **Temporary pavement markings.** Temporary pavement markings are included in the MUTCD and define travel lanes and provide guidance and information for the road user through the work zone. Consider using these depending on:
 - a. Whether new traffic pattern will be in place for more than three days
 - b. The time of year, as this may affect the type of marking suitable for application
 - c. The complexity of the change in traffic pattern
 - d. The duration of the project, as markings that need to be in place for longer periods may warrant permanent paint pay items instead of temporary paint
 - e. Removable tape or line striping targets are required if the temporary markings are on the final pavement layer.
- 8. **Flaggers and uniformed traffic control officers.** These individuals can direct road users and pedestrian traffic in work zones. Consider these options when:
 - a. Maintaining two-way traffic in a single lane
 - b. Side roads enter a flagger-controlled travel space
 - c. Haul roads require stopping one direction of traffic while construction vehicles enter/exit
- 9. **Automated Flagger Assistance Devices (AFADs).** AFADs are portable traffic control systems that assist a flagger operation for short-term lane closures, on two-lane highways and are described in the MUTCD. For a typical flagging operation with AFADs, one or both

flaggers can be positioned a short distance away from the roadway and moving traffic if they have an unobstructed view of both devices and approaching traffic. A flagger(s) can use a radio control unit or an attached cable to operate an AFAD(s). Flaggers using these devices must have received training on proper usage. Consider these devices:

- a. If it is a short-term closure. Since these devices must be operated manually, they must be operated during the time flaggers are available.
- b. If it is not a mobile operation. AFADs take additional time to set up and remove.
- c. When a temporary signal is not warranted. A specific approach sign package is required for the use of these devices.

10. Work zone speed management.

- a. Reduced speed limits should be used only in the specific portion of the (temporary traffic control) TTC zone where conditions or restrictive features are present. However, frequent changes in the speed limit should be avoided. A TTC plan should be designed so that vehicles can travel through the TTC zone with a speed limit reduction of no more than 10 mph.
- b. Reduced speed zoning (lowering the regulatory speed limit) should be avoided as much as practical because drivers will reduce their speeds only if they clearly perceive a need to do so.
- c. A reduction of more than 10 mph in the speed limit should be used only when required by restrictive features in the TTC zone. Where restrictive features justify a speed reduction of more than 10 mph, additional driver notification should be provided. The speed limit should be stepped down in advance of the location requiring the lowest speed, and additional TTC warning devices should be used.

11. **Pace or pilot vehicle.** When traffic is routed through an extended work zone with multiple activity areas. These work zones many times have a serpentine travel path for motorists which is not intuitively obvious thus requiring a pilot car.

12. **Temporary traffic signals.** Fixed or portable temporary traffic signals are described in the MUTCD and can improve traffic flow through and near the work zone and/or address safety concerns. Shall be installed when there is one lane with two-way traffic that must be maintained 24 hours/day.

13. **Lighting devices.** In addition to allowing the highway workers to see their work, lighting can assist the drivers to better understand changes to the roadway and pedestrians to see and be seen. Included in the MUTCD, lighting is required when doing nightwork and should also be considered when construction is occurring during the winter or other times when lighting may be limited. The environmental regulations for illumination should be followed.

1.C) Innovative or Accelerated Construction Techniques

Special materials such as quick-curing concrete or pre-cast items (e.g., culverts, bridge deck, or pavement slabs) lessen the duration of construction or maintenance activities where traffic restrictions need to be minimized such as roadways with high volumes. Consider cost/benefit of accelerated construction vs. normal construction practices; longer detours may be palatable for shorter construction periods. Accelerated construction may include full roadway closures, round-the-clock work, or off-site prefabrication. Inconvenience to the traveling public and

businesses should be balanced by shorter overall durations and reduced worker exposure to traffic. Innovative or accelerated construction techniques may include:

1. Prefabricated/precast elements
2. Rapid cure materials
3. 'Slide' bridge installation
4. Geotech abutment sections
5. Full roadway closures
6. Round-the-clock work

1.D) Project Coordination Strategies

These strategies have the potential to reduce mobility and safety impacts of work zone activities, including coordination with:

1. **Other area projects.** Sequencing, and scheduling area projects in coordination can minimize motorist delay and impacts on potentially effected businesses and communities.
2. **Utilities.** Coordinating and scheduling utility work both within the impacted work zone area and near the project can minimize potential work disruptions or interruptions resulting from utility work and reduce overall construction duration. Coordinating two or more jobs concurrently can also reduce the recurrence of work zones. For example, the installation of a new water main or power along an interstate corridor may coincide with a pavement reconstruction project on that interstate.
3. **Right-of-way.** Anticipating and planning to address potential right-of-way needs and issues may help reduce project delays and duration.
4. **Other transportation infrastructure.** Coordination with non-highway transportation facilities such as transit junctions, railroad crossings, or other intermodal facilities can help minimize traffic disruptions.

1.E) Innovative Contracting Strategies

These strategies typically involve contractual agreements to reduce the project duration or traffic impacts, including:

1. **Construction Manager/General Contractor (CMGC).** In CMGC, the owner, here VTrans, hires a contractor to provide input such as identifying risk, providing cost projections and refining the project schedule, during the design phase. Once the design process is complete, the contractor and owner negotiate the price for the construction contract. The involvement of the contractor in the design phase allows the introduction of best practices, new innovations and reduced costs and risks.
2. **Design-build.** This strategy uses a single contract to design and build the project, which reduces the project duration by allowing the construction to begin prior to design completion.
3. **A+B bidding.** This strategy encourages contractors to minimize construction impacts by reducing construction time. Part A refers to the contractor's bid for the actual items of work, and Part B is the total number of days bid to complete the projects multiplied by the daily

road user cost stipulated in the contract. The combined values of the A and B portions determine the winning bid. The contractor's payment is based on both Part A and the actual number of days used under Part B.

4. **Incentive/disincentive clauses.** This strategy involves using incentives and/or disincentives in the construction contract to minimize construction duration.
5. **Lane rental.** This strategy involves a charge assessed to the contractor when a portion of the roadway is obstructed and unavailable to traffic. The contractor's bid includes an estimate of the number of hours that closures will be in place, with the actual payment to the contractor based on the actual use of closures. The lane rental charge can vary according to:
 - a. Time of day
 - b. Day of week
 - c. Project season
 - d. Number of lanes impacted
 - e. Duration
6. **Performance specifications.** This strategy is a document that specifies the operational requirements of the construction operation period.

1.F) Construction Considerations

These considerations are typically used when a project will run for an extended duration. Consideration of the TTC that are necessary to ensure safety and mobility during transition times such as the following is necessary:

1. **Switch over between phases.** This may be any time a project shifts focus, such as when a project needs marker changes or at the end of a project, when pavement markings are being painted.
2. **Winter shutdown.** If a project will take more than one construction season, but may not be worked on over the winter, special attention should be given to the work zone shutdown and space required to provide winter maintenance activities.

2) Transportation Operations (TO)

Transportation operations strategies can mitigate work zone impacts by using improved transportation operations and management of the transportation system. TO strategies typically include:

- 2.A) Demand Management Strategies
- 2.B) Corridor/Network Management Strategies
- 2.C) Work Zone Safety Management Strategies
- 2.D) Incident Management and Enforcement Strategies
- 2.E) ITS Implementation
- 2.F) ITS Performance Monitoring Strategies

2.A) Demand Management Strategies

Demand management strategies include techniques to reduce the volume of traffic traveling through the work zone, including diverting travelers to alternate modes, shifting trips to off-peak hours, or shifting vehicles to alternate routes. These strategies typically involve working with local officials and employers to implement these strategies and may include:

1. **Transit service improvements.** Where appropriate, transit service improvements may include modifying transit schedules and/or routes, increasing frequency, or establishing transit service in the corridor.
2. **Transit incentives.** Transit incentives include employer and/or traveler transit subsidies and guaranteed ride home programs.
3. **Shuttle services.** Shuttles and charter buses can reduce traffic volumes or accommodate pedestrian traffic through a work zone.
4. **Ridesharing/carpooling incentives.** Rideshare/carpool incentives can reduce the number of vehicles traveling through a work zone. Incentives may include preferential parking for carpools, the addition of mainline HOV lanes or bypass lanes on ramps, or providing vanpool vehicles.
5. **Park-and-ride promotion.** Creating, expanding, and/or promoting (advertising) park-and-ride lots to encourage ridesharing or transit use can reduce the number of vehicles traveling through the work zone.
6. **Telecommuting.** Telecommuting allows motorists to work at home, or at a telecommuting center near home, either full or part time. Encouraging motorists who normally travel through the work zone to telecommute for the duration of the project can reduce the demand.
7. **Pedestrian and bicycling accommodations.** When a project will impact roadway users, but shorter trips are possible by human powered modes, alerting users to those possibilities and improving connections and accommodations can reduce the vehicular demand.

2.B) Corridor/Network Management Strategies

This category includes traffic operations techniques and technologies to optimize traffic flow through the work zone corridor and adjacent roadways.

1. **Signal timing/coordination improvements.** Retiming traffic signals can increase throughput of the roadway(s), improve traffic flow, and optimize intersection capacity in and around the work zone especially when construction conditions or detours have modified traffic patterns.
2. **Temporary traffic signals.** Installing temporary traffic signals can improve traffic flow through and near the work zone. At a corridor or network level, using temporary traffic signals is more effective than STOP signs or flaggers for providing mobility through the work zone area. These temporary traffic signals may also be coordinated with existing signals.
3. **Roadway/intersection improvements.** Improvements on roadways and intersections in the workzone and/or alternate routes may be necessary to provide increased capacity to handle the traffic through the work zone or within the adjacent corridor. This may involve

improvements to the mainline and intersections, including roadway and/or shoulder widening, additional through and/or turn lanes, and removing parking.

4. **Bus turnouts.** Constructing bus stop areas that are recessed from the travel lanes may be helpful in work zones or on detour routes with a high occurrence of bus traffic and stops.
5. **Emergency pullouts.** Providing areas where vehicles can pull out of traffic can reduce the extent and duration of traffic congestion related to disabled vehicles and crashes blocking travel lanes within the work zone.
6. **Turn restrictions.** Restricting turn movements for driveways and/or intersections can increase roadway capacity, reduce potential congestion and delays, and improve safety. Restrictions may be applied during peak periods or all day.
7. **Parking restrictions.** Eliminating parking in all or part of the work zone and/or alternate routes, or restricting parking during work hours or peak traffic periods can increase capacity by converting the parking lane to an additional travel lane, reduce traffic conflicts, or provide improved access to the work area. In many cases, replacement parking will need to be provided.
8. **Truck/heavy vehicle restrictions.** Imposing restrictions on truck travel through the work zone, either during specific periods or at all times, can increase passenger vehicle capacity of the roadway when a facility normally has a high truck volume. When using this strategy on interstate routes, follow the requirements of 23 CFR Part 658.11 (d) (1) and (g) and communicate closely with the Vermont Department of Motor Vehicles.
9. **Reversible lanes.** Also known as variable lanes or contra-flow lanes, this strategy involves sharing lane(s) of travel to accommodate peak period traffic flow. The direction of travel in the shared lane varies by time of day or day of the week.
10. **Dynamic lane closure system.** Also called dynamic lane merge system, the system uses dynamic electronic signs and other special devices to control vehicle merging at the approach to lane closures.
11. **Railroad crossings traffic control.** This strategy includes enhancing vehicular traffic control improvements at a railroad crossing where Work Zone delays and congestion have the potential to force vehicles to stop on the tracks or between the crossing gates.
12. **Coordination with adjacent construction site(s) and/or detours.** Combining or coordinating projects within a corridor or area can minimize the combined impacts on the motoring public and community. Coordination typically involves scheduling projects to ensure that adequate capacity remains available to accommodate the anticipated travel demand within the corridor by not implementing work zones on adjacent or parallel highways at the same time. This may entail communicating about the timing of lane closures and occurrence of incidents and coordinating diversion routes. It may also involve completing needed capacity and safety improvements on a highway prior to using it to carry traffic diverted or detoured from another project.
13. **Rolling road blocks.** Provide a method to temporarily slow traffic speeds for a minimal amount of time (a maximum of 20 minutes) rather than completely stopping traffic. This strategy should only be conducted on limited-access highways within the State of Vermont and should be done at low volume daylight period in good weather.

2.C) Work Zone Safety Management Strategies

Use this category of devices, features, and management procedures to address traffic safety concerns in work zones. Work zone safety management strategies include:

1. **Speed limit reduction/speed limit based on condition.** Reduced work zone speed limits may improve traffic safety and protect workers. See relevant Traffic Engineering Instruction for guidance on this strategy.
2. **Temporary traffic signals.** In some work zones, temporary traffic signals can be used in place of traffic control officers or flaggers, which may increase safety by removing these personnel from the roadway. This strategy is also listed in other strategy categories.
3. **Temporary traffic or positive barrier.** Temporary traffic barriers, also called positive barriers, provide positive physical separation between travel lanes and the adjacent workspace, or between opposing travel lanes. These barriers are described in detail in Chapter 2 of this Guidance.
4. **Traffic screens.** These screens reduce driver distractions in work zones, which can help to keep traffic moving and enhance safety. Mount screens on the top of temporary traffic barriers to discourage gawking and reduce headlight glare.
5. **Milepost markers.** Milepost markers are signs located in the shoulder off the edge of the road, which list location information (route, town, county, mileage). Some areas may refer to these as location reference markers because they can be used to mark direction; route, bridge, or overpass names; or intersection names, in addition to mileage information.
6. **Movable traffic barrier systems.** This system involves a mechanical transfer machine, which quickly shifts temporary barriers laterally to the full width of a travel lane while protecting both the transfer operation and traffic in the work zone. This system permits rapid and safe reconfiguration of the traffic barrier system, allowing daily opening and closing of lanes for reversible-lane operations and providing additional space for the contractor to work during off-peak conditions.
7. **Crash cushions.** Also known as an impact attenuator, a crash cushion is a fixed or mobile barrier used to protect a temporary hazard or prevent vehicle intrusion into the workspace or other hazardous area. It works by gradually decelerating the vehicle to a stop or by redirecting the vehicle away from the hazard and is designed based on the prevailing speed on the roadway. This strategy is defined in the MUTCD.
8. **Truck mounted attenuators (TMAs)** can prevent damage to vehicles, structures, and prevent injuries from erratic drivers and are defined in the MUTCD. Consider using a TMA:
 - a. At the leading end of the work zone where errant vehicles could enter and endanger workers and/or the vehicle operators but only where sufficient length is available for the TMA to roll forward if struck.
 - b. Where access is maintained for construction materials and equipment. The TMAs prevent errant vehicles from impacting construction equipment or workers, and protect motorists from significant hazard (e.g., bridge out, deep excavation, etc.).
 - c. On shadow vehicles for moving operations.

TMAs should not be used for crash attenuation at the terminal ends of temporary barrier or without a channelizing taper in a static work zone.

9. **Temporary rumble strips.** Rumble strips are grooves or raised strips placed across or adjacent to a travel lane to alert motorists to a change in roadway conditions or that they have strayed out of the travel lane.
10. **Intrusion alarms.** Various types of sensors can detect vehicles that stray out of the travel lane approaching or adjacent to the workspace and into the work area. When an intrusion is detected, a loud siren and/or flashing lights provide a warning to workers.
11. **Warning lights.** Various types of warning lights, as described in the MUTCD, are available to alert drivers and pedestrians and draw attention to critical signs, channelizing devices, and other work zone features.
12. **Automated Flagger Assistance Devices (AFADs).** AFADs are portable traffic control systems that assist a flagger operation for short-term lane closures, on two-lane highways and are described in the MUTCD. For a typical flagging operation with AFADs, one or both flaggers can be positioned a short distance away from the roadway and moving traffic if they have an unobstructed view of both devices and approaching traffic. A flagger(s) can use a radio control unit or an attached cable to operate an AFAD(s). Flaggers using these devices must have received training on proper usage. Consider these devices:
 - a. If it is a short-term closure. Since these devices must be operated manually, they must be operated during the time flaggers are available.
 - b. If it is not a mobile operation. AFADs take additional time to set up and remove.
 - c. When a temporary signal is not warranted. A specific approach sign package is required for the use of these devices.
13. **Project task force/committee.** This strategy creates a project task force or committee to address safety and/or traffic control within the work zone and adjacent corridor.
14. **Construction safety/inspectors.** Daily inspection and supervision of safety and/or traffic control operations is an integral part of project management and can be provided by contractor or agency personnel, as appropriate to their specific project responsibilities.
15. **Road safety audits.** Road safety audits involve analyzing a future or existing roadway by an independent expert on safety issues. It is a proactive way to reduce crashes and identify potential safety hazards. Audits may be performed during any phase of a road project, including planning, preliminary design, detailed design, traffic control planning, construction, pre-opening, and on existing roads.
16. **TMP monitor/inspection team.** This strategy involves establishing a team (or person) to monitor and inspect implementation and monitoring of the work zone transportation management strategies.
17. **Team meetings.** The project team meets regularly to discuss TMP strategies, implementation, and monitoring, particularly related to safety.
18. **Project on-site safety training.** Ongoing safety training ensures workers are familiar with safety procedures and specific risks associated with the project and maintains a high level of safety awareness.
19. **Windshield surveys.** This strategy involves a designated VTrans employee and/ or contractor driving through the work zone area to conduct a firsthand assessment of safety and/or traffic flow. This strategy provides periodic assessments of the effectiveness of project safety features.

2.D) Incident Management and Enforcement Strategies

Work zone traffic management strategies involve monitoring traffic conditions and adjusting traffic operations based on changing conditions. Because changing conditions may involve traffic incidents, this category also looks at traffic incident management strategies early in the project development process and throughout as the project is designed and constructed. These strategies involve improved crash detection, verification, response, and clearance; mechanical failures; and other incidents in work zones and on detour routes. This category also includes strategies to provide adequate enforcement of traffic regulations in work zones.

1. **Media coordination.** This strategy involves working with local news media to publicize traffic delays, incidents, and incident management. Working with media contacts in advance to establish procedures in the event of a major delay or incident can facilitate the dissemination of information when a major delay or incident occurs.
2. **Local detour routes.** Advance identification and approval/authorization of local detour routes is an especially useful strategy to address major traffic delays and incidents, particularly for high-volume and incident-prone work zones.
3. **Tow/freeway service patrol.** This strategy uses dedicated or on-site (or near site) towing services to reduce the time required to remove vehicles involved in a breakdown or crash.
4. **Contract support for incident management.** This strategy provides additional contract support for incident management and response beyond what is available from the construction contractor or within the agency. Contracts may include police agencies, towing/recovery providers, engineering consultants, or others, depending on the type of support needed.
5. **Incident/emergency management coordinator.** This strategy gives a designated individual overall responsibility for incident and emergency management on a project. Responsibilities may include developing incident and/or emergency response plans, overseeing implementation and monitoring of the work zone management strategies, and overall management of incidents or emergencies.
6. **Incident/emergency response plan.** Developing a plan with information needed to respond to an incident typically includes roles and responsibilities, response agencies, processes/procedures, actions to take for various incident types and levels, contact information, alternate routes, personnel and equipment information, staging area locations, and other information appropriate to the individual project.
7. **Dedicated (paid) police enforcement.** This strategy provides police patrols in the work zone under a contractual arrangement with the agency or contractor. Check with Agency Policy regarding traffic officer presence versus enforcement.
8. **Cooperative police enforcement.** Cooperative enforcement is similar to dedicated enforcement, except it is implemented through a cooperative agreement between the police and agency. Check with Agency Policy regarding traffic officer presence versus enforcement.

2.E) Intelligent Transportation Systems Implementation

Intelligent transportation systems (ITS) apply high technology and computer power to current highway, traffic, and transit systems. Work zone traffic management strategies involve monitoring traffic conditions and adjusting traffic operations based on changing conditions.

Combined, the implementation of ITS can make a work zone safer for all involved. Some techniques that can be implemented are:

1. **ITS for traffic monitoring/management.** Use ITS in work zones to identify areas where traffic flow is impeded to provide traveler information and/or adjust the work zone. A work zone ITS deployment uses sensors to detect traffic conditions and can automatically feed this information to motorist information outlets such as CMS and websites, or to a TMC. Monitoring traffic cameras can help detect places where drivers are having difficulty negotiating a work zone and can then adjust the layout.
2. **Transportation management center (TMC).** A TMC can coordinate and manage traffic and incident management activities in and around the work zone.
3. **Helicopter or drones for aerial surveillance and incident investigation.** Use aerial surveillance to identify and verify traffic problems and assist with crash investigation in the timely manner.

2.F) Intelligent Transportation Systems Performance Monitoring Strategies

ITS implementation can be, and should be, monitored for effectiveness throughout the project. There are several ways in which to determine the effectiveness of implementation:

1. **Public surveys.** This can be done through windshield surveys, an email questionnaire, or during an in-person meeting. This strategy provides periodic assessments of the effectiveness of project safety features.
2. **Surveillance of traffic queues/delays.** Surveillance equipment can help to identify traffic problems and detect areas where queues are forming in the work zone.
3. **Surveillance of travel times.** Surveillance equipment can help to identify traffic problems and detect, verify and respond to incidents in the work zone to reduce travel times. This can also help to determine problem areas in the work zone to reduce travel times.

3) Public Information

Including a public information component in the TMP can reduce work zone impacts by providing road users and the community with information concerning road projects and alerting them to potential impacts and how to avoid them. The strategy can also provide general information concerning appropriate driving and travel behavior and travel options associated with the work zone. Involving affected communities and businesses early in project development, and keeping them informed throughout the project is essential to identify potential impacts and to ensure effective mitigation strategies are developed and implemented. Coordination with local government or planning commissions will help to ensure success, particularly for significant projects. This section deals with:

- 3.A) Outreach Planning
- 3.B) Public Awareness Strategies
- 3.C) Motorist Information Strategies

For additional guidance on Public Outreach, refer to VTrans' Public Involvement Guide.

3.A) Outreach Planning

A work zone public information and outreach campaign involves several strategies for communicating with road users, the general public, area residents and businesses, and appropriate public entities regarding road construction projects. Develop public information and outreach campaigns for work zones, particularly those identified as significant. This section describes the steps in developing a campaign.

1. **Determine the Appropriate Size and Nature of the Campaign.** This effort can be determined by the anticipated impacts of the road construction project. For a short-lived, small project causing minor traffic disruption, public information and outreach may be limited to routine publication of a press release on the VTrans website or social media and in local newspapers. A longer, more disruptive work zone warrants a more elaborate public information and outreach campaign. Consider a range of elements when determining the size and nature of a public information and outreach campaign. These include the effects of the project on:
 - a. Traffic delay and safety at both corridor and network levels, including the effects on parallel corridors and alternate routes
 - b. Traffic delay and safety at nearby intersections, interchanges, and railroad crossings
 - c. Special traffic and safety conditions such as heavy truck traffic and poor weather
 - d. Disruptions of other transportation modes, including public transportation, pedestrian, and bicycle access
 - e. Evacuation routes
 - f. Hazardous material transportation routes
 - g. Emergency responders
 - h. Other public and private entities (such as schools and universities)
 - i. Planned special events (holiday parades, concerts, etc.)
 - j. Tourist attractions
 - k. Businesses and residences
2. **Identify Resources.** To be successful, a public information and outreach campaign must be supported with enough resources and therefore should be considered when developing project budgets. Both internal VTrans resources and external resources (such as regional planning commissions) can play a role in developing and implementing a public information and outreach campaign. Internal resources include VTrans staff, facilities, and equipment (websites, changeable message signs). External resources may involve paying for public relations expertise (possibly including graphic design and Web design); radio, TV, and newspaper advertising; printing; or a public information center or kiosk. Low-cost or free external resources may include radio and TV traffic broadcasts, newspaper articles, and help from project partners. The budget for a work zone public information and outreach campaign depends on several factors, including the size and nature of the campaign, the communication strategies selected, whether the selected strategies are already established by VTrans and can readily be used, and the role of partners.
3. **Identify Partners.** Consider working with a range of partners in both the planning and implementation stages of public information and outreach campaigns. Partners in the public information and outreach process may include:

- a. State and local agencies
- b. Elected and appointed public officials
- c. Adjacent Regional Planning Commissions
- d. Major employers and service providers (e.g., federal and local agencies, hospitals, etc.) in the affected area
- e. Other groups such as neighborhood associations, business associations, etc.
- f. Chambers of Commerce, etc.
- g. Traveler information providers, including radio, TV, and newspapers

Major reasons for including these partners are to:

- a. **Establish lines of communication.** These connections are particularly important during major periods of disruption and when changes occur.
- b. **Distribute information.** Involving outside groups in planning an outreach campaign is a way to distribute information. Holding a meeting with the aim of soliciting community input, for example, is also a way to inform the public of disruptions and plans to deal with them.
- c. **Improve the product.** Partners in developing outreach strategies bring unique perspectives about successful types of messages and methods of communication. This may be particularly important in areas with diverse population groups (e.g., non-English speaking communities, truck drivers, or the elderly).
- d. **Share the costs.** Partners may be willing to share the cost of producing materials or to provide free forms of advertising. For example, major employers are often willing to incorporate messages in company communications and on their websites.

One way to obtain input from affected parties is through a Working Group of stakeholders from the affected community. Ideally developed during the planning stage of the project, the objective of creating such a group is to obtain input and review/comment on the development and implementation of construction and transportation management strategies to minimize the impacts of the project on the community. Both VTrans and the contractor may meet with the Working Group to obtain input and recommendations throughout the project, starting during planning and extending through design, construction, and project assessment.

While meeting with stakeholders is important, meeting with local businesses and business organizations is also an important element of a public information and outreach effort. Businesses are a conduit for providing project information because they have a vested interest in communicating what they know with customers and suppliers. In addition, these meetings provide businesses the opportunity to suggest ways to manage a project that can minimize negative effects. Below is a list of Possible Stakeholders and Interested Parties. The list is not inclusive and will vary depending on project complexity.

VTrans Internal Partners

- › Internal partners
- › Communications Section

VTrans Jurisdictional Partners

- › Federal agencies
- › Other Vermont State agencies
- › Regional Planning Commissions
- › City/Town agencies
- › Other

Highway Users

- › Local drivers/local deliveries
- › Commuters/regional and through trips
- › Trucking industry
- › Heavy-haul trucking companies
- › Annual permit holders
- › Local bus companies
- › Charter/Tour bus companies
- › School districts (school buses)

Local Officials

- › Mayor/City Council
- › Town Manager/Selectboards/Highway Department
- › Fire/Ambulance

Property Owners and Property Residents

- › Directly affected by project (top priority)
- › Adjacent to project
- › Other property owners on right-of-way

Community Residents

- › People living in the neighborhood
- › People living in the vicinity
- › People living in the highway corridor
- › Commuters traveling the highway corridor

Other Affected Community Agencies

- › Local/State Police
- › Emergency operations managers
- › Schools and school transportation coordinators
- › Hospitals
- › Parks
- › Area attractions/entertainment venues/fairgrounds/festival organizers
- › Other

Local business community

- › Businesses affected by the project (top priority)
- › Businesses in the neighborhood

- › Businesses in the vicinity
- › Businesses in the highway corridor

Environmental Justice

- › Low-income communities
- › Minority communities
- › Translations needed
- › Other

Civic Organizations

- › Chambers of Commerce/city club/visitor association
- › Local community service clubs
- › Local neighborhood associations
- › Visitor Bureau
- › Other

4. **Identify Target Audiences.** A key to any public information and outreach campaign is to identify the target audience(s). This will help to determine the types of messages to be conveyed and the best methods of communicating those messages. Identify audiences through three categories, as shown in the table below. An outreach campaign must also consider the different types of people affected by a work zone. Certain groups may need special information or information provided in a different way. Residents who live near an upcoming work zone are often a primary audience as they may be affected by the work zone daily. Large groups, limited English-speaking residents, the elderly, children, or the disabled might also warrant special consideration.

Public Information and Outreach Campaign Audiences:

a. Types of Travelers

- Pre-trip
- En route
- Personal—local, commute
- Personal—local, non-commute
- Personal—non-local (e.g., tourists)
- Commercial—local
- Commercial—non-local (long distance)

b. Types of Trip Generators

- Major employers
- Schools/colleges
- Shopping districts/malls
- Recreation and tourist facilities (e.g., parks, ski resorts)
- Organizers of planned special events
- Emergency responders/hospitals
- Business associations

- Associations
 - Intermodal passenger terminals
 - Intermodal freight terminals
- c. Types of People**
- Residents (and neighborhood associations)
 - Minorities (particularly groups with limited English-speaking capability)
 - Special demographics (particularly elderly, children, disabled)
 - Business owners
5. **Develop Campaign Message(s).** The three messages generally incorporated into successful work zone public information and outreach campaigns are:
- a. **Safety First.** The most important message is to encourage motorists to take safety precautions to protect themselves and highway workers. Continuously remind drivers to adhere to posted speed limits and stay alert to prevent crashes. Reinforce this message with warnings about increased traffic fines and enforcement activity, if appropriate.
 - b. **Work zone expectations.** Work zone disruptions can be reduced when travelers plan ahead. Additionally, travelers who know what to expect will be less frustrated by delays. Another general message is to think ahead about the timing of travel, the route, the mode, and the destination.
 - **Work zone details.** Employ a variety of public information and outreach strategies to provide current details of a work zone, including websites, project hotline, newspaper articles, changeable message signs (CMS), and others. At a minimum, work zone details should include the dates and times of work zone activity and the routes, lanes, and ramps affected. If these details are changing, it is important to provide the most current information. Incorrect and out-of-date information compromise the effectiveness of a public information and outreach campaign.
 - **Travel times, average speed and delays.** Public information on travel times and delays can range from very general (e.g., “Expect delays”) to very specific (e.g., “Travel time through work zone is 20 minutes”). Color code average speed by segments and display them on the Website. More specific information is usually more useful to travelers and preferable when it is available.
 - **Alternate methods and modes of transportation.** Reducing the amount of traffic through a work zone is one way to reduce congestion and travel delay. This may involve providing detailed information on carpooling/ ridesharing, transit, park and ride, and telecommuting options. Target messages regarding telecommuting to major employers and commuters.
 - **Alternate routes.** In many cases, alternate routes must be devised and communicated to travelers. These routes may differ, depending on the type of driver (local, long distance, commercial drivers) and timing. Alternate route messages are essential when construction involves shutting down an entire route. Locate alternate route messages that may involve CMS at decision points for drivers.
 - c. **“Working together to get you there.”** Motorists are more willing to cooperate with disruptions and cooperate with directions when they feel that all necessary steps are

- being taken to make things easier. Accepting inconvenience related to the work performed is more likely with a genuine message from those involved.
6. **Determine communication strategies.** After identifying the appropriate audience and messages for the work zone project, the next step is to determine the strategies to be used to get the messages to the target audiences. While there are many ways to communicate with the public about work zones, tailor strategies to the project context, the message being conveyed, and funding limitations.
 7. **Modify communication strategies to fit the needs of each project.** A combination of several strategies may make sense for some projects, while only one or two may be necessary for others. A communication strategy is only useful when it is known by the public; VTrans employees must consider public internet access limitations when communicating about a project. Consider a mix of media, such as brochures mailed to nearby addresses and published on the municipality's website.
 8. **Determine when to communicate.** A public information and outreach campaign must develop and implement strategies before construction begins and after the project is complete. In the before phase, concentrate the campaign on general information about the project, the problems it may cause, and where to find more information. Near the commencement date of a work zone, it may be appropriate to add other methods such as free media coverage and paid advertising, a hotline, and CMS.
 9. **Evaluate Effectiveness.** During a long-term construction project, periodically evaluate the effectiveness of the public information and outreach campaign with the aim of redirecting resources if necessary. An evaluation might:
 - a. Document and report the impacts of the work zone, such as the number of crashes and traffic delay.
 - b. Document and report questions, comments, compliments, and complaints received via hotline, Website, letter, etc.
 - c. Assess perceptions of successes and failures among the project partners.
 - d. Survey public, businesses, or commercial truck drivers affected by the work zone.
 - e. Survey tourism bureaus (ski resorts, etc.) or other major facilities near the work zone.

Evaluation tools include:

a. Pre-project Baseline Survey

- Electronic survey
- Postcard survey
- Telephone survey
- Other

b. Public Meeting Survey

- Ballot survey
- Crowd preference survey
- Electronic survey
- Other

c. Mid-Construction Survey

- Postcard survey
- Telephone survey
- Electronic survey
- Other

d. End-of-Project Survey

- Postcard survey
- Telephone survey
- Electronic survey
- Other

3.B) Public Awareness Strategies

These strategies include methods to educate and reach out to the public, local businesses, and the community concerning the project and work zone:

1. **Brochures and mailers.** These are printed materials containing project-related information, such as advanced notice of the project's start date, schedules, pictures/graphics of the project, a description of the need for the project, alternative routes, etc. These may be distributed to motorists at key locations (e.g., large employers in the project area, rest stops, travel information centers), via automobile associations, or mailed to affected businesses or communities.
2. **Press releases/media alerts.** This strategy provides project-related information to the news media, affected businesses, and other affected or interested parties using print and/or electronic media. Outreach to radio, television, and newspapers should be a cornerstone for any public information campaign. It is important to establish a working relationship with reporters to encourage positive publicity and accurate information.
 - a. **Earned media:** this is free media, such as news stories and traffic information. Large projects are generally considered newsworthy by local media outlets, so it can be relatively easy to get news coverage.
 - b. **Paid media:** paid announcements may use newspaper, radio, or television ads. These can be used for progress updates, or to provide information regarding major changes to the work zone configuration. Paid advertising can be expensive but may be a cost-effective way to reach a wider audience.
3. **Project information center.** Typically located on or near the project site for a large project, the facility could contain materials such as scale model displays, maps, brochures, videos, etc., describing the project, its potential impacts, and available alternatives to minimize the impacts.
4. **Telephone hotline.** This traveler information system provides traffic or travel information for the work zone using a toll-free telephone number. It can include prerecorded messages and/or real-time interactive request and response information.
5. **Planned lane closure website.** This strategy is typically not for individual projects but is usually implemented for an entire region/jurisdiction. VTrans has (at the time of

- publication) a website that lists projects and includes location, type of work, and expected closures. Local planning commissions may also have websites for traffic information.
6. **Project website/Multiple projects website.** This traveler information system provides traffic or travel information for the work zone via the web/Internet. It can include both long-term static information and/or real-time interactive information and be part of a much larger work zone website. When multiple projects are closely spaced, information can be provided on a joint site.
 7. **Public meetings/hearings.** This strategy involves public relations staff presenting project information to the public, community, and/or businesses, and soliciting input concerning potential concerns, impacts, and management strategies.
 8. **Community task forces.** Develop community task force(s) that include community stakeholders likely to be affected by the work zone (businesses, neighborhood groups, interested individuals, public officials, or other representatives). Task forces can be a means of providing information and receiving input related to a road project.
 9. **Coordinate with media/schools/businesses/emergency services.** Coordinate with groups likely to be affected by the work zone that can disseminate needed information. Examples of these groups include local/cable TV newsrooms, schools and school districts, local major employers/businesses, and local emergency services (fire, police, and ambulance). Establish various mechanisms such as email, phone message, mailings, etc., to communicate project-related information, including start dates, project schedules, significant traffic pattern changes, and traffic crashes and incidents within the work zone.
 10. **Email/listserv alerts.** Email alerts provide travelers with timely information on work zone activity and traffic delays. Lane closures, delays, and incident/crash information are distributed to travelers who have signed up to receive the information via computer, cell phone, or mobile device.
 11. **Work zone safety highway signs.** This strategy uses signs placed strategically at work zone approaches to increase driver awareness to work zone safety concerns.
 12. **Social Media.** This strategy can communicate project-related information that could be static (e.g. project dates) and/or real time (e.g. potential delays).
 13. **Educational Videos.** Project videos can be prepared and circulated for use at events, presentations, and on municipal websites.

3.C) Motorist Information

These strategies provide current and/or real-time information to road users regarding the project work zone. Motorist information strategies include:

1. **Changeable Message Signs (CMS).** Place these fixed or portable message boards along roadways or at key locations to notify road users of lane and road closures, work activities, incidents, potential work zone hazards, queues and slowed or stopped traffic ahead, and travel time or delay information, as well as alternate routes in or around the work zone. Place CMS at key locations before potential diversion points to give motorists an opportunity to divert to an alternate route or take other appropriate measures based on the information provided. As an enforcement tool, these signs can also be used to inform drivers of work

zone speed limit reductions and enforcement activities. The MUTCD provides specific guidance regarding CMS.

2. **Temporary motorist-information signs.** Temporary conventional signs mounted in the ground, overhead, or on vehicles to provide traveler information to guide motorists through the work zone and warn of potential hazards.
3. **Dynamic speed message sign.** This portable system can be mounted as a fixed sign or located on a portable trailer. Radar measures the speed of approaching vehicles, which is displayed at the transition point noted in the temporary speed certificate with a regulatory speed limit posted with it. The objective of this system is to enhance safety by reducing speeding and minimizing speed variations throughout the work zone.
4. **Project information hotline.** Use a toll-free telephone number to provide prerecorded messages and/or real-time traffic or travel information for the work zone.
5. **Traffic Radio.** Disseminate project-related information through regularly scheduled radio traffic reports.
6. **Highway Advisory Radio (HAR).** Use HAR when it is necessary to provide longer, more detailed messages than can be conveyed using signage. HAR involves disseminating information to motorists while en route over wide-area wireless communications directly to in-vehicle radios. Signs inform motorists of the radio frequency where the information is available.
7. **Extinguishable signs.** These signs are typically associated with HAR systems where the sign indicates how to obtain information on roadway conditions (e.g., tune in to 1610 AM). These signs turn on and off, depending on when the HAR has a message available.
8. **Traveler information systems (New England Compass 511).** Using such technology as cell phones, pagers, in-vehicle systems, and e-mail notifications, this strategy provides motorists with work zone-related information and static (e.g., project dates) and/or real time (e.g., potential delays).
9. **Freight travel information.** This is an appropriate strategy when there is a moderate to high percentage of freight movement through the work zone. It involves coordinating with the freight community (trucking companies, truck drivers, etc.) to identify work zone information considered useful (e.g., truck restrictions, occurrences of incidents, and planned closures) and developing a mechanism to disseminate that information to freight stakeholders. Information dissemination can be to central locations (e.g., email distribution list to trucking companies) or to truckers as they approach the work zone.

This page intentionally left blank.

3

Special Aspects of Work Zone Safety and Mobility

Chapter 3 provides additional guidance on issues of particular concern to FHWA and critical to establishing safe work zones for highway workers and road users. In compliance with 23 CFR 630 Subpart K, states need to provide guidance and establish minimum requirements to address the following areas of concern, including:

- › Positive Protection Devices
- › Safe Entry and Exit of the Work Zone
- › Installation and Maintenance of Temporary Traffic Control Devices (630.1110 - TEI)
- › Law Enforcement at Work Zones
- › Work Zone Pay Items

Many of these items are listed or referenced in the other sections of the Work Zone Safety and Mobility Guidance, however, due to the particular attention raised by FHWA, VTrans has dedicated a chapter to specifically address these items.

POSITIVE PROTECTION DEVICES

In 23 CFR 630.1108(a) of Subpart K, FHWA provides the circumstances under which practitioners shall consider use of positive protection. These conditions are work zone situations that place workers at increased risk from motorized traffic and where positive protection devices offer the highest potential for increased safety for highway workers and road users.

At a minimum, the CFR indicates positive protection devices shall be considered for:

1. Work zones that provide workers no means of escape from motorized traffic such tunnels and bridges.
2. Work zones of two weeks or more that result in substantial worker exposure to motorized traffic.

3. Work zones located on roadways with operating speeds of 45 mph or greater.
4. Work zones that place workers close to travel lanes open to traffic.
5. Work zones that result in roadside hazards such as drop offs or unfinished bridge decks that will remain in place overnight or longer.

VTrans Construction Standards and the AASHTO Roadside Design Guide chapter on Traffic Barriers, Traffic Control Devices, and other Safety Features for Work Zones provide direction on the need to include channelization devices or barrier based on different geometric features or longitudinal drop-offs. To supplement this information, VTrans has prepared guidance regarding use of positive protection as outlined below.

The proposed use of positive protection should be considered based on one, or a combination of, the following site characteristics. In addition, chart is provided on Standard T-35 regarding conditions regarding barrier:

- › **Project Duration.** Projects greater than two weeks in length where workers are in close proximity to traffic thereby increasing the risk of vehicle intrusion in the work area (consistent with FHWA).
- › **Site Operating Speed.** Work zones where the non-work zone posted speed limit or 85th percentile speed is equal to or greater than 45 mph (consistent with FHWA).
- › **Volumes:** On roadways where the AADT is 15,000 or greater.
- › **Worker Protection.** At locations such as bridges where workers have no means of escape from motorized traffic.
- › **Driver Protection.** At locations with drop-offs that will remain in place overnight or longer.
- › **Fixed Objects.** Equipment, materials or other fixed objects that remain in the work area overnight.
- › **Interstate or Divided, Limited Access Facilities.** Bypasses for bridge construction or roadway reconstruction. Longer bypasses (1 mile or greater) may use positive protection devices for shifts and approaches and may use surface mounted vertical delineation devices (tubular markers) on tangents based on an economic analysis.

Positive Barrier Use Guidelines

When positive barrier is utilized in projects, the following guidelines should be considered:

- › Positive barrier should be installed tangentially with a desired minimum 2-foot offset from the traveled lane to the face of the barrier at its widest point. The lateral offset should not be less than 1 foot. On higher speed facilities, the lateral offsets should be maximized to the extent possible.
- › Where there is little to no tolerance for deflection within the work area, the barrier systems identified as having minimal deflection in the AASHTO Roadside Design Guide should be considered. On a case by case basis, anchoring barrier to roadway surface or bridge deck may be considered. This option may result in holes in the finished deck and therefore affect the lifespan of the deck.

- › Tapers for positive barrier are based on posted or off peak 85th percentile operating speed of the facility as seen in the MUTCD or VTrans Standard Drawings.
- › Unprotected ends of the barrier on US and State Routes should be tapered at 10 to 30 feet outside the edge of the traveled lane based on guidance in the AASHTO Roadside Design Guide. If the positive barrier cannot be tapered outside the minimum clear zone of 10 feet, then an appropriate crash attenuator shall be provided to protect the end of the barrier. Truck mounted attenuators should not protect the ends of barrier but may be used to close off or protect the work area if adequate roll distance is available.
- › Unprotected ends of the barrier on interstates and other limited access multi-lane facilities should be tapered to the clear zone as defined in the latest edition of the AASHTO Roadside Design Guide. If the positive barrier cannot be tapered outside the minimum clear zone, then an appropriate crash attenuator shall be provided to protect the end of the barrier.
- › Consider and plan for how construction materials will be delivered to the job site and how equipment will be accommodated behind the barrier. Positive barrier may need to be opened temporarily.
- › Access to businesses and residences must be delineated and blunt ends of the barrier must be properly treated.

Exceptions

For moving operations such as paving projects where barrier is not practical, but exposure is still long in duration (MUTCD defines as three days or longer), other methods should be incorporated to protect highway workers and road users, see Control Measures section for alternate methods of reducing worker exposure. Limited access facility projects employing long crossovers and two-lane, two-way operations may use surface mounted vertical delineation devices (tubular markers) instead of concrete barrier on tangents based on an economic analysis and engineering judgment. Consider use of tubular markers when the risk to road users and highway workers to place temporary barrier and the high overall cost of placing the barrier offsets the advantages of providing positive separation.

In addition to positive protection, VTrans recommends the use of exposure control measures to minimize exposure of highway workers. These strategies are listed and described in more detail in Chapter 3 as Control Strategies and include:

- › Full road closures
- › Median crossovers
- › Lane shift/closures
- › Ramp closures
- › Night or weekend work
- › Off site detours/diversions to alternate routes

Along with positive protection and other exposure control methods, Truck Mounted Attenuators (TMAs) have proven an effective piece of equipment when used appropriately. Additional information on TMAs is provided in Chapter 3 of this Guidance as well as in the MUTCD and AASHTO Roadside Design Guide.

SAFE ENTRY AND EXIT OF THE WORK ZONE

When designing a work zone, it is critical to consider the safe entry and exit of the Work Zone for vehicles and equipment. When TTC plans are developed, the entry and exit points of the work zone shall be indicated. When using VTrans Standard Drawings or MUTCD Typical Applications, the access to the work zone needs to be described via a narrative to ensure that the access has been designed, and will be implemented, safely in the field.

INSTALLATION AND MAINTENANCE OF TRAFFIC CONTROL DEVICES

When project construction begins all TTC devices should be new or like new. In the course of the project, TTC devices should be maintained to meet the American Traffic Safety Services Association's (ATSSA) level 1, Acceptable. The ATSSA Quality Guidelines for Work Zone Traffic Control Devices uses photos and written descriptions to help judge when a traffic control device has outlived its usefulness. These guidelines are available for purchase from ATSSA through the following URL: <https://www.workzonesafety.org/publication/quality-guidelines-for-work-zone-traffic-control-devices/>.

VTrans provides guidance regarding acceptable condition of TTC devices via Traffic Engineering Instruction TEI 18-605 VTrans Standards for Temporary Traffic Control Devices.

Refer to the Standard Specifications for Construction for details and guidance on payment for the installation, interim movement and removal of all traffic control items.

LAW ENFORCEMENT USE

This section provides guidance for the use of uniformed law enforcement on Federal-aid highway projects. The goal of these guidelines is to reduce the likelihood of injuries and fatalities to highway workers and road users in Work Zones, while maintaining a fiscally responsible approach to the use of flaggers and uniformed traffic officers. These guidelines provide parameters to identify the appropriate need and consistent use of flaggers and uniformed traffic officers, addressed by the following categories:

- › **Traffic Control Operations** (guiding and directing traffic in, through, and around a work zone)
- › **Presence** (deter speeding and aggressive driving, encourage drivers to cautiously proceed through the work zone)
- › **Enforcement** (actively enforce traffic laws within the work zone on an as needed basis to gain driver awareness rather than as a full-time operation)
- › **Emergency Assistance** (assist and coordinate activities at accident sites within the work zone, report accidents)

Each of the aspects listed here are outlined in more detail below.

Traffic Control Operations

Flaggers shall be used to the greatest extent possible for dynamic traffic control operations. However, the use of uniformed traffic officers may be necessary in some instances.

Examples of dynamic traffic control operations where flaggers should be used include:

- › Alternating 1-way traffic (stop/slow paddles must be used).
- › Controlling traffic at low volume intersections (one flagger per approach).
- › Assisting trucks and equipment in and out of work areas.
- › Controlling traffic at side roads and driveways during mobile operations (i.e. paving, striping, etc.).
- › Directing pedestrians and bicyclists through the work zone.
- › Providing detour guidance beyond work zone limits, if needed.

Examples of dynamic traffic control operations where uniformed traffic officers may be used include:

- › Directing traffic through complex intersections, especially where signal indications are being countermanded (signal shall be placed in flashing mode).
- › Assisting construction vehicles and equipment in and out of work areas on high speed, high volume facilities. Note: If an access area is anticipated to be in place for an extended period of time and it is determined that assistance is required for the safe exit and entry of construction vehicles, then a cost analysis should be completed to determine if stationary measures (i.e. signals) would be more cost effective than officers or flaggers.
- › Rolling roadblock operations on interstates and other multi-lane limited access highways.

Presence

The use of flaggers or uniformed traffic officers for presence should only be used when there is an added safety risk to the highway workers and road users due to speeding, other aggressive driving behaviors, and/or high traffic crash/incident rates attributed to other features such as poor highway geometrics.

The use of police vehicles should be considered for nighttime operations in most instances, as the use of flashing blue lights, visible from 360 degrees, has been proven to deter aggressive driving behavior. However, the manner of their use during nighttime operations should be carefully considered as police vehicle lights provide no positive direction to motorists traveling through the work zone and are often overpowering and distracting. Excessive use of police vehicles with lights at night, or the inappropriate positioning of these vehicles, may actually detract from the positive guidance the work zone temporary traffic control devices provide. When used for nighttime work, flashing blue lights shall be dimmed if capable.

Though typically not necessary, uniformed traffic officers may also be used for presence on roads with posted speeds of less than 45 mph or ADT volumes less than 10,000 vehicles per day

if the resident engineer determines that a police presence is needed to address a specific safety issue.

NOTE: Using the flashing blue lights from a police vehicle to slow traffic approaching a work zone with poor visibility (i.e. East-West sun glare) or poor sight distance due to geometric features should be considered only after other measures have been determined to be ineffective.

Enforcement

The following guidelines are recommended to reduce the likelihood of injuries and fatalities to workers and road users by enforcing traffic laws within work zones. Enforcement can only be performed by uniformed traffic officers.

Enforcement may be used during work zone operations where excessive speed and/or other aggressive driving behaviors are likely to jeopardize the safety of the workers and other road users. Enforcement may be used on an as needed basis within a work zone either by itself or where another officer is being used for presence to improve that officer's effectiveness.

Uniformed traffic officers being used for presence should typically not be used for enforcement except for flagrant violations of traffic law.

If an arrest is necessary, the work zone detail uniformed officer shall either:

- › Call in, and turn the arrest over to, an on-duty officer.
- › Call in a replacement UTO to cover work zone duties.

Emergency Assistance

Emergency assistance is immediate assistance in emergency situations, such as a motor vehicle crash within the limits of the work zone. The detail officer may investigate minor property damage crashes that occur within the work zone if the time required to complete the investigation is minimal and the detail officer is not actively engaged in directing traffic. The detail officer should limit investigation of minor property damage crashes to assure that no injuries are involved. Crashes involving injury should be investigated by the appropriate personnel once other emergency personnel arrive at the scene, not the detail officer.

Pay for Uniform Traffic Control Officers

Uniformed traffic officers conducting traffic control or for presence are paid in accordance with the VTrans Standard Specifications. Uniformed Traffic officers (UTOs) used for law enforcement are not paid under VTrans item 630.10. Designers can request law enforcement by adding an estimated dollar amount on the Contract Plan Submittal form under the line, "Worksite Traffic Control \$\$." This is not a bid item but is paid under a statewide contract between the Agency and Vermont State Police and is used at the discretion of the Resident Engineer. Prior to submission of Plans, Specifications, and Estimates, the designer will prepare an estimated number of traffic control officer hours to Contract Admin. If contractor is developing TCPs, Contract Admin will provide that number to the contractor. Resident engineers can also access this contract during construction via a change order.

PAYMENT GUIDELINES FOR WORK ZONE TRAFFIC CONTROL ITEMS

Project level procedures, project plans, specifications and estimates shall include appropriate pay item provisions for implementing the TMP, including TTC plans. Per the CFR, VTrans pay provisions include:

1. Payment for work zone traffic control features shall not be included for other items of work not related to traffic control and safety.
2. Lump sum payment should be limited to items for which an estimate of the actual quantity required is provided in the PS&E or for items where the actual quantity required is dependent upon the contractor's choice of work scheduling and methodology. A contingency provision should be included such that additional payment is provided if the quantity or nature of the required work changes, either an increase or decrease, due to circumstances beyond the control of the contractor.
3. Separate pay items shall be provided for critical categories of traffic control devices, as outlined in this chapter, including positive protection devices and uniformed law enforcement activities. Estimates for these items shall be determined during design and provided to Contract Admin for provision to the contractor. Unit price payment should be provided for those items over which the contractor has little or no control over the quantity and no firm estimate of quantities is provided in the PS&Es, but over which VTrans has control of the actual quantity to be provided for the project.

This page intentionally left blank.

REFERENCES AND OTHER GUIDANCE

This page intentionally left blank.

References and Other Guidance

This Guidance attempts to provide enough information for practitioners to plan, design, construct and evaluate work zones that provide safety and mobility to highway worker and the traveling public, however there are many additional sources of information that provide additional guidance. Links to applicable websites at the time of publication of this document are provided below. In addition, because pedestrian and cyclist mobility through work zones is of particular concern, the July 2018 Vermont Bicycle and Pedestrian Work Zone Traffic Control Guide is provided in its entirety.

REFERENCES

CFR, Specifications, MUTCD and TEIs

23 CFR 630 Subpart J: <https://www.govinfo.gov/content/pkg/CFR-2012-title23-vol1/pdf/CFR-2012-title23-vol1-part630-subpartJ.pdf>

23 CFR 630 Subpart K: <https://www.govinfo.gov/content/pkg/CFR-2012-title23-vol1/pdf/CFR-2012-title23-vol1-part630-subpartK.pdf>

Specifications Page: <https://vtrans.vermont.gov/highway/construct-material/construct-services/pre-contractspecifications/active>

Part 6 MUTCD (TTC): <https://mutcd.fhwa.dot.gov/pdfs/2009/part6.pdf>

FHWA Work Zone Management Program: <https://ops.fhwa.dot.gov/wz/resources/policy.htm>

TEIs: <https://vtrans.vermont.gov/docs/engineering-instructions>

Public Involvement Guide and Project Examples:

<https://vtrans.vermont.gov/sites/aot/files/highway/documents/publications/VTransPublicInvolvementGuide2017.pdf>

[Middlebury Bridge & Rail Project Document Library | Agency of Transportation \(vermont.gov\)](https://vtrans.vermont.gov/road-construction)

<https://vtrans.vermont.gov/road-construction>

<https://www.ccrpcvt.org/about-us/news/traffic-alerts/>

<http://watp.vtransprojects.vermont.gov/>

<https://vtrans.vermont.gov/projects/i89-resurfacing>

<http://nhgi.vtransprojects.vermont.gov/>

This page intentionally left blank.

TMP CHECKLIST

This page intentionally left blank.

TMP CHECKLIST

Purpose: To make a preliminary determination of whether the following issues are present or should be considered during project development through a more detailed TMP.

Initial Project Significance Level (as determined in Table 4): _____

Project Manager during Project Definition:

Name: _____ Date: _____

Modified or Approved by (Project Manager at Preliminary Design for Significant Projects):

Name: _____ Date: _____

Modified or Approved by (Project Manager at PS&E for Significant Projects):

Name: _____ Date: _____

Project Description (Location, Activity, Anticipated Duration):

	Yes	No	Poss	N/A	Comments
17. Does the project require a long-term (greater than 3 days) ¹ lane or roadway/bridge closure?	<input type="checkbox"/>	<input type="checkbox"/>	<input type="checkbox"/>	<input type="checkbox"/>	
18. Are there any restrictions or considerations regarding construction timeframes due to traffic concerns (e.g., time of day, site specific time of year limits)?	<input type="checkbox"/>	<input type="checkbox"/>	<input type="checkbox"/>	<input type="checkbox"/>	
19. Can typical applications for traffic control be used? Are there any limitations to when typical applications can be used (time of year, times, days)?	<input type="checkbox"/>	<input type="checkbox"/>	<input type="checkbox"/>	<input type="checkbox"/>	
20. Is there a sidewalk, pedestrian/bicycle lane, path, trail, or access that needs to be maintained during construction?	<input type="checkbox"/>	<input type="checkbox"/>	<input type="checkbox"/>	<input type="checkbox"/>	
21. Is a speed reduction proposed (consistent with state guidance)?	<input type="checkbox"/>	<input type="checkbox"/>	<input type="checkbox"/>	<input type="checkbox"/>	
22. Will temporary roadways or additional width be needed on culverts, bridges, or shoulders to maintain traffic?	<input type="checkbox"/>	<input type="checkbox"/>	<input type="checkbox"/>	<input type="checkbox"/>	
23. Will construction impact access to businesses?	<input type="checkbox"/>	<input type="checkbox"/>	<input type="checkbox"/>	<input type="checkbox"/>	
24. Are there other projects (utility, district maintenance, construction, municipal) in the area that should be coordinated or avoided?	<input type="checkbox"/>	<input type="checkbox"/>	<input type="checkbox"/>	<input type="checkbox"/>	

	Yes	No	Poss	N/A	Comments
25. Will/Can the traffic be reasonably detoured? If no or N/A, proceed to #10. If yes or possibly:	<input type="checkbox"/>	<input type="checkbox"/>	<input type="checkbox"/>	<input type="checkbox"/>	
g. Is the detour route roadway type equivalent to closed roadway?	<input type="checkbox"/>	<input type="checkbox"/>	<input type="checkbox"/>	<input type="checkbox"/>	
h. Is the local alternate detour route in good condition?	<input type="checkbox"/>	<input type="checkbox"/>	<input type="checkbox"/>	<input type="checkbox"/>	
i. Will the detour route have a detrimental impact on emergency vehicles, school buses, or other sensitive traffic?	<input type="checkbox"/>	<input type="checkbox"/>	<input type="checkbox"/>	<input type="checkbox"/>	
j. Are there load limit restrictions on the detour?	<input type="checkbox"/>	<input type="checkbox"/>	<input type="checkbox"/>	<input type="checkbox"/>	
k. Are there bridge/culvert width or height restrictions on the detour?	<input type="checkbox"/>	<input type="checkbox"/>	<input type="checkbox"/>	<input type="checkbox"/>	
l. Are modifications needed at intersections on detour/alternate routes?	<input type="checkbox"/>	<input type="checkbox"/>	<input type="checkbox"/>	<input type="checkbox"/>	
26. Will traffic signal timing need to be adjusted for the project (with or without a detour)?	<input type="checkbox"/>	<input type="checkbox"/>	<input type="checkbox"/>	<input type="checkbox"/>	
27. Are there truck facilities or routes that would be impacted by the project or by a detour (turning radii, weight restrictions, etc.)?	<input type="checkbox"/>	<input type="checkbox"/>	<input type="checkbox"/>	<input type="checkbox"/>	
28. Are there special events or traffic generators (schools and bus routes, large employers, hospitals) that may be affected by the project and/or detour?	<input type="checkbox"/>	<input type="checkbox"/>	<input type="checkbox"/>	<input type="checkbox"/>	
29. Will the emergency vehicle routing, mail delivery, school bus routes, or trash services be interrupted by the project (with or without a detour)?	<input type="checkbox"/>	<input type="checkbox"/>	<input type="checkbox"/>	<input type="checkbox"/>	
30. Are there specific stakeholders to engage regarding the work zone impacts?	<input type="checkbox"/>	<input type="checkbox"/>	<input type="checkbox"/>	<input type="checkbox"/>	
31. Does the project occur within a high crash location?	<input type="checkbox"/>	<input type="checkbox"/>	<input type="checkbox"/>	<input type="checkbox"/>	
32. Are there other maintenance of traffic issues to consider? Specify.	<input type="checkbox"/>	<input type="checkbox"/>	<input type="checkbox"/>	<input type="checkbox"/>	

1. MUTCD definition of long-term work is occupying a location more than 3 days.

Additional Narrative for Not Significant Projects with issues identified above:

VERMONT BICYCLE AND PEDESTRIAN WORK ZONE TRAFFIC CONTROL GUIDE

This page intentionally left blank.



Vermont Bicycle and Pedestrian Work Zone Traffic Control Guide

Issued – July 2018



Prepared By: VTTrans Bicycle and Pedestrian Program

Table of Contents

1. GLOSSARY	1
2. PREFACE	2
3. BICYCLE AND PEDESTRIAN ACCOMODATION	3
3.1 ACCESSIBILITY REQUIREMENTS.....	3
4. ELEMENTS OF A TEMPORARY TRAFFIC CONTROL PLAN	4
5. WORK ZONE DESIGN FOR PEDESTRIANS	5
5.1 PEDESTRIAN ACCOMMODATION PRINCIPLES	6
5.2 TEMPORARY PEDESTRIAN SIGNALS	8
5.3 PEDESTRIAN CHANNELIZING DEVICES (PCD) – SELECTION & PLACEMENT	8
5.4 TEMPORARY PATHWAY ALIGNMENTS.....	9
5.5 DEVICE PLACEMENT	10
5.6 COVERED PATHWAYS.....	11
5.7 PATHWAY LIGHTING	12
5.8 TEMPORARY SIGNING	13
5.9 WORK ZONE DESIGN FOR CONSTRUCTION IN AREAS WITH NO SIDEWALK.....	17
5.10 ROAD CLOSURES	17
6. WORK ZONE DESIGN FOR BICYCLISTS	18
6.1 BICYCLE ACCOMMODATION PRINCIPLES.....	18
6.2 BICYCLE DETOURS	19
6.3 FLAGGERS.....	20
6.4 “OUTSIDE THE BOX” ALTERNATIVES.....	20
6.5 TEMPORARY SIGNING	20
6.6 CHANNELIZING DEVICES	23
6.6.1 BICYCLE CHANNELIZING DEVICE (BCD)	28
7. SHARED USE PATHS	29
8. OTHER CONSIDERATIONS	30
References	32
APPENDIX A – BICYCLE CORRIDOR PRIORITY MAP	33
APPENDIX B – PEDESTRIAN AND BICYCLIST TTC CHECKLIST	34
APPENDIX C – WORK ZONE TRAFFIC CONTROL DETAILS	35

1. GLOSSARY

Bicycle Facilities

A general term for denoting improvements and provisions that accommodate or encourage bicycles, including shared roadways not specifically defined for bicycle use (i.e. roadway shoulders)

Bicycle Lane (Bike Lane)

A portion of roadway that has been designated for preferential or exclusive use by bicyclists through pavement markings and, if used, signs.

Bikeway

A generic term for any road, street, path, or way that in some manner is specifically designated for bicycle travel, regardless of whether such facilities are designated for the exclusive use of bicycles or are to be shared with other transportation modes. Bikeways include shared-use paths, bike lanes, and any road or street with shared lane markings.

Delineator

A retroreflective device mounted on the roadway surface or at the side of the roadway in a series to indicate the alignment of the roadway, especially at night or in adverse weather.

Designated Bicycle Route

A system of bikeways designated by the jurisdiction having authority with appropriate directional and informational route signs, with or without specific bicycle route numbers.

Detectable

Having a continuous edge within 6 inches of the surface so that pedestrians who have visual disabilities can sense its presence and receive usable guidance information.

Flagger

A person who actively controls the flow of vehicular traffic into and/or through a temporary traffic control zone using hand-signaling devices or an Automated Flagger Assistance Device.

Intermediate Duration Work

Stationary work that occupies a location more than one daylight period up to 3 days, or nighttime work lasting more than one hour.

Long Term Work

Stationary work that occupies a location for more than three days.

Mobile Work

Work that moves intermittently or continuously (line striping, sign replacement, etc.)

Pathway

A general term denoting a public way for purposes of travel by authorized users outside the traveled way and physically separated from the roadway by an open space or a barrier and either within the highway right-of-way or within an independent alignment. Pathways include shared use paths, but do not include sidewalks.

Pedestrian

A person on foot, in a wheelchair, on skates, on a skateboard, or using any other type of mobility device.

Pedestrian Access Route

A continuous and unobstructed path of travel provided for pedestrians with disabilities within or coinciding with a pedestrian circulation path.

Pedestrian Circulation Path

A prepared exterior or interior surface provided for pedestrian travel in the public right-of-way.

Shared Roadway

A roadway that is open to motor vehicle travel and upon which no bicycle lane is designated.

Shared-Use Path

A facility used by bicyclists and pedestrians outside the traveled way and physically separated from motorized traffic by an open space or barrier and either within the highway right-of-way or within an independent alignment. Pedestrians include walkers, joggers, skaters, skateboarders, and manual and motorized wheelchair users.

Short Duration Work

Work that occupies a location up to one hour.

Short Term Work

Stationary work that occupies a location for more than one hour within a single daylight period.

Shoulder

The portion of roadway contiguous with the traveled way for accommodation of breakdown vehicles, pedestrians, and bicyclists.

Sidewalk

That portion of a street between the curb line or the lateral line of a roadway, and the adjacent property line or on easements of private property that is paved or improved and intended for use by pedestrians.

2. PREFACE

This document discusses practices relating to the design and implementation of a traffic control plan for pedestrians and bicyclists in work zones. These recommendations and examples apply to construction, maintenance, and utility work and provide information to aid in developing Temporary Traffic Control (TTC) Plans for pedestrians, bicyclists, and persons with disabilities.

Part 6 of the Manual on Uniform Traffic Control Devices (MUTCD) provides the fundamental principles of Work Zone traffic control, including the design of signs, pavement markings and devices. The Vermont Work Zone Safety and Mobility Guidance Document and its Appendix A provides additional information on the use of temporary traffic control devices, flaggers, and uniformed traffic officers to control and minimize worker exposure to traffic hazards and to increase road user safety, and can be accessed at <http://vtrans.vermont.gov/docs>. A TTC Plan generally includes a constructability assessment led by the designer to ensure the efficacy of the work zone and its traffic control provisions for all roadway users.

3. BICYCLE AND PEDESTRIAN ACCOMODATION

As part of the Vermont Agency of Transportation’s commitment to the safety of all roadway users within work zones, the accessibility and safety of bicyclists and pedestrians shall be considered during the planning and development of TTC Plans.

The extent of temporary facilities provided depends on several factors including:

- The type of facility being impacted by construction activities and/or staging (i.e. sidewalk, shoulder, bike lane, etc.)
- The duration of the activity impacting these facilities
- The known and/or projected use of the facility by bicyclists or pedestrians

The highest level of temporary facility will be provided when a facility specifically intended for bicycling or walking is impacted (e.g. sidewalk, bicycle lane or shared-use path).

When sidewalks, shared use paths, or roadway shoulders are closed due to construction, a temporary facility should match (or exceed) the level of accessibility that existed before construction wherever possible or practical.

Chapter 6D of the MUTCD comprehensively addresses pedestrian safety considerations for temporary traffic control. The same level of considerations discussed in the MUTCD for walking is applicable to other modes of transportation through the work zone, including bicycling.

It is important to consider the work zone needs of bicyclists and pedestrians as early as possible in the project development process. A temporary walkway or bikeway may require the use of property outside the existing right-of-way and identifying these needs prior to the right-of-way acquisition process is critical. Although there may be times where it is infeasible to fully meet the needs of bicyclists and pedestrians, every effort should be made to address their access and safety in the TTC plan.

3.1 ACCESSIBILITY REQUIREMENTS

Per the MUTCD Section 6A.01:

The needs and control of all road users (motorists, bicyclists, and pedestrians within the highway, or on private roads open to public travel...including persons with disabilities in accordance with the Americans with Disabilities Act of 1990 (ADA), Title II, Paragraph 35.130) through a TTC zone shall be an essential part of highway construction, utility work, maintenance operations, and the management of traffic incidents.

When a work zone disrupts existing pedestrian facilities, an equivalent Temporary Pedestrian Access Route (TPAR) shall be provided. Temporary pedestrian facilities must be accessible to and usable by pedestrians with disabilities. TPARs may include sidewalks, temporary walkways, street crossings, refuge islands, curb ramps, detectable warning surfaces, pedestrian signals and push buttons, and pedestrian route signage.

The TPAR must comply with the MUTCD and shall meet or exceed the level of accessibility present on the current circulation route. Recommendations made by the US Access Board in the Public Right-of-Way Accessibility Guidelines (PROWAG) shall be considered when developing the TTC Plan for any work zone

activity that affects pedestrian facilities within the right-of-way. These considerations include, but are not limited to, the provision of curb ramps, detectable barriers, and detectable warning surfaces in the design of TTC Plans.

Accessibility requirements for temporary pedestrian facilities are described in the PROWAG section R205:

“When a pedestrian circulation path is temporarily closed by construction, alterations, maintenance operations, or other conditions, an alternate pedestrian access route complying with sections 6D.01, 6D.02, and 6G.05 of the MUTCD shall be provided. Where provided, pedestrian barricades and channelizing devices shall comply with sections 6F.63, 6F.68, and 6F.71 of the MUTCD”.

Details on accessibility elements of a TTC Plan are found in Section 5 of this document. Additional information and requirements on accessible design of sidewalks can be accessed at: <https://www.access-board.gov/guidelines-and-standards/streets-sidewalks/public-rights-of-way>

4. ELEMENTS OF A TEMPORARY TRAFFIC CONTROL PLAN

A TTC Plan describes means and methods for facilitating vehicle, bicycle and pedestrian traffic through a work zone, usually for roadway, maintenance, or utility projects. The degree of detail of the TTC Plan is dependent on the complexity of the situation, i.e. what facilities are being closed or reduced, the work to be performed, the duration of the work, and the volume of traffic through the work zone (vehicles, bicycles, and pedestrians). Some form of a TTC Plan shall be included on all projects. The TTC plan should be developed by someone with engineering expertise and thorough knowledge of the MUTCD.

Ideally, the TTC Plan is developed by the project designer. In the case where a contractor proposes an alternate TTC Plan, the submitted proposal shall include complete details, including all aspects of traffic control, to the same extent provided by the project designer.

The scope of a TTC Plan will vary based on project complexity. Items that may be included in the TTC Plan include:

- **Public Notice:** Through use of a Public Information Officer, Portable Changeable Message Boards, Front Porch Forum, Town websites, or other means, planned closures should be communicated to the traveling public before work commences. This should include information specific to planned closures of sidewalks or bicycle facilities, if applicable. Available detours or alternate routes should also be communicated to reduce traffic flow and delay in and around the work zone.
- **Signs:** Appropriate selection and placement of warning and regulatory signs for vehicles, bicycles, and pedestrians shall be included to warn of a change in conditions and possible diversions or detours. In all cases, signs shall be clear, direct, and consistent throughout the work zone. General guidance on appropriate sign selection and placement can be found in Parts 2 and 6 of the MUTCD.
- **Temporary Facilities:** Temporary pedestrian and bicycle facilities including sidewalks, temporary surfaces, detectable barriers, line striping, curb ramps, and lighting should be included where necessary to ensure the safety of pedestrians and bicyclists traveling on a diverted route. In the case of pedestrian facilities (sidewalks, shared use paths) impacted by construction, routes must meet accessibility standards outlined in the PROWAG and MUTCD.

- **Channelizing Devices:** Channelizing devices may be used to enhance the safety and separation of pedestrians and bicyclists from work zone activities and vehicular traffic through work zones. The type, quantity, and placement of these devices may vary throughout each phase of a project as work zone conditions change; each stage should be accounted for in the TTC Plan. Additional guidance for selection and placement of channelizing devices can be found in Parts 6, 9, and Chapter 2B of the MUTCD.
- **Detours:** The TTC Plan may include a detour for pedestrians and/or bicyclists. This route should be well thought out, with consideration to length, grade, surface condition, drainage and runoff, and connectivity. Alternatives to detours such as shuttle services or work zone escorts may be provided to guarantee pedestrian and bicyclist mobility if a detour exceeds the distance that average pedestrians and bicyclists are likely to travel (half mile for pedestrians and 2 miles for bicyclists.) More on bicycle detours can be found in section 6.2 of this document.

All traffic control devices and methods included in the TTC Plan must adhere to the standards set forth in the MUTCD. This document provides *additional* guidance to enhance the safety of pedestrians and bicyclists in work zone areas. Each phase of construction should be accompanied by a unique TTC Plan that addresses safety and mobility of pedestrians and bicyclists specific to the project area.

5. WORK ZONE DESIGN FOR PEDESTRIANS

Detailed TTC Plans for pedestrians are required when existing sidewalk facilities are disrupted, closed, or relocated in a work zone. The temporary facilities shall be detectable and include accessibility features consistent with the features present in the existing pedestrian facility.

The principles discussed in the MUTCD Chapters 6C, 6D, 6F and 6G address minimal requirements needed to accommodate pedestrians in work zones.

The TTC Plan must provide specific traffic control measures and accessible features to accommodate all pedestrian traffic. Pedestrians require a useable, traversable, clearly defined pathway through or around a work zone. Key components in an accessible pathway include:

- *Accessible Features* – sidewalk curb ramps, landing areas, transit platform edges, etc.
- *Detectable Features* – truncated domes, curbs around fountains or pools, detectable channelizing devices, signs with audible features, etc.

Schools, shopping malls, theatres, arenas and similar pedestrian generators may result in sudden, large volumes of pedestrians in a concentrated section of a work zone. Carefully consider the location and elements of needed temporary pathways to safely and effectively guide pedestrians through or around work zones in these areas.

The preferred pedestrian accommodation (in order) is as follows:

1. Maintain an accessible sidewalk on at least one side of the roadway
2. Maintain an accessible pedestrian access route using road space when available (i.e. shoulder, parking lane, etc.)
3. Provide a pedestrian detour using existing sidewalks
4. Provide alternate means for pedestrians to move through the work zone e.g. escorts or shuttles

For site-specific conditions or configurations not addressed by the MUTCD, the TTC Plan designer must provide additional design details within the TTC Plan.

5.1 PEDESTRIAN ACCOMMODATION PRINCIPLES

When accommodating pedestrians in work zones and developing a pedestrian-specific TTC Plan, consider the following:

- Do not lead pedestrians into conflicts with traffic, construction vehicles, equipment, operations, or hazardous materials. Ensure protection when holes or trenches are adjacent to existing pedestrian facilities.
- Where practical, when directing pedestrians across a roadway, use existing intersection corners and crosswalks – marked or unmarked. Avoid developing temporary mid-block crossings if possible. An existing marked mid-block crossing may be used to shorten alternate pedestrian routes. The location of crosswalks must include adequate sight lines for motorists and pedestrians.
- Provide a convenient, continuous and accessible path that equals or exceeds, as practical, the existing pedestrian facilities. All surfaces, including temporary walkways, shall be firm, stable, and slip resistant. Routes shall be free of debris or protruding objects that prohibit passage (signs, hoses, barriers, materials, vehicles or equipment.)
- Coordinate with local agencies, as necessary, if alternate pedestrian routes are located on their facilities (including private roadways). Ensure pedestrian access and any traffic control materials (channelizing devices, signs, etc.) on their facilities are approved before the TTC Plan is completed and the project is released for advertisement.
- If work activities displace transit stops and other pedestrian access points, the TTC plan shall address how pedestrians access those points. For instance, flaggers may be used to safely assist pedestrians. However, if the situation will exist during times when workers are not present, the project engineer or supervisor will need to establish a proper diversion path to the transit stop, or relocate the transit stop to a more pedestrian-accessible location and provide sufficient signing/wayfinding information to the new location. This will require that agencies and contractors work with the transit agency to relocate the stop. Pedestrians should not be forced to cross active work spaces to reach bus stops or access points.
- Minimize out-of-direction travel for pedestrians.
- If closing a pedestrian route, sign the closure in **advance** at the nearest crossing or diversion point. Avoid having a pedestrian route double back on itself.
- If it is known that pedestrians with visual impairments may be impacted by a work zone, designers should consider the use of signs that provide detailed audible information about the work zone. These audible devices should adhere to the standards found in the MUTCD.
 - *A barrier or barricade detectable by a person with a visual disability is sufficient to indicate that a sidewalk is closed. If the barrier is continuous with detectable channelizing devices for an alternate route, accessible signing might not be necessary. An audible information device is needed when the detectable barricade or barrier for an alternate channelized route is not continuous. (MUTCD, Section 6F.14)*
 - *The most desirable way to provide information to pedestrians with visual disabilities*

that is equivalent to visual signing for notification of sidewalk closures is a speech message provided by an audible information device. Devices that provide speech messages in response to passive pedestrian actuation are the most desirable. Other devices that continuously emit a message, or that emit a message in response to use of a pushbutton, are also acceptable. (MUTCD, Section 6D.02)

- Provide temporary sidewalk facilities that meet accessibility requirements, including the following standards which shall be provided to the maximum extent feasible:
 - Maximum running slope of 8.3% for curb ramps
 - Maximum cross slope of 2.0% on sidewalks, curb ramps and landings
 - 60-in. sidewalk widths; or, 48-in. widths with 60-in. x 60-in. level landings (max. 2% slope) every 200 feet

- VTrans Standards C-3A and C-3B detail sidewalk curb ramps, pedestrian refuge islands, and sidewalk crossings of rail lines. Temporary pedestrian facilities are to be equal to or improve upon existing facilities. All temporary pedestrian facilities shall be accessible.
 - Examples of temporary curb ramp requirements are shown below.
 - Detectable warning surfaces shall meet the requirements of PROWAG section R305.

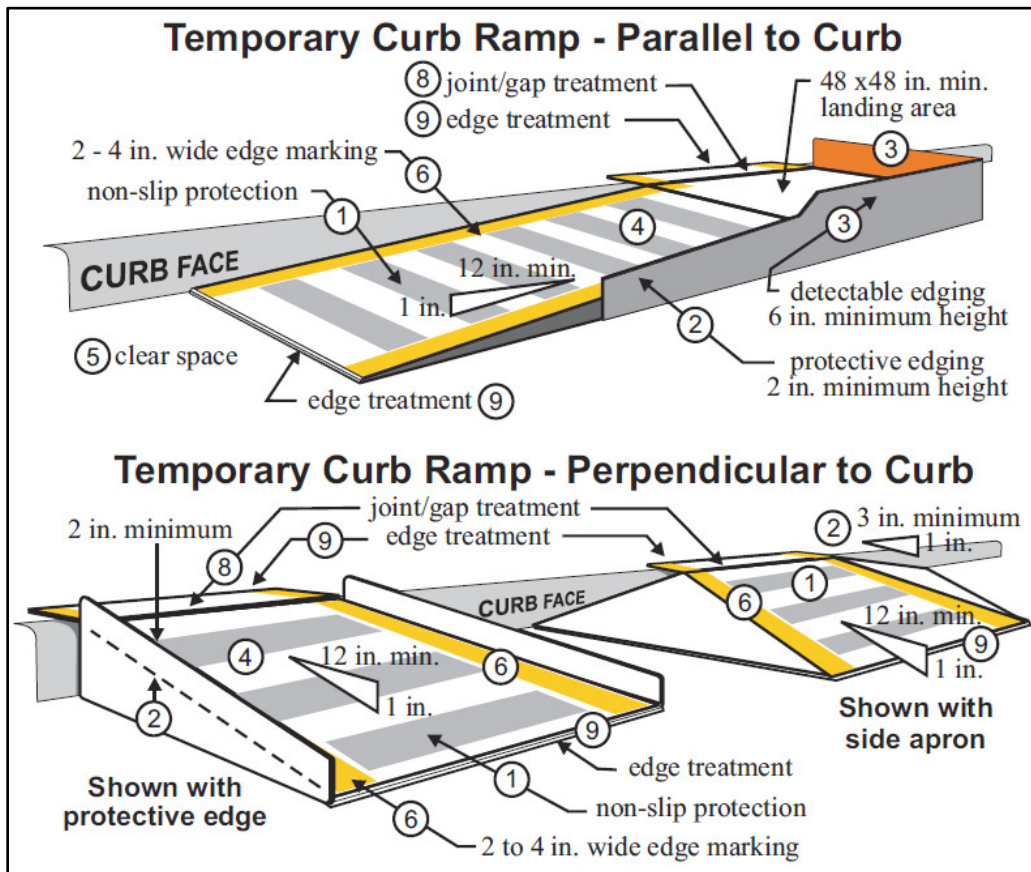

Temporary Curb Ramp Notes:

1. Curb ramps shall be 48 in. minimum width with a firm, stable, non-slip surface.
2. Protective edging with a 2 in. minimum height shall be installed when the curb ramp or landing platform has a vertical drop of 6 in. or greater or has a side apron slope steeper than 1:3 (33%). Protective edging should be considered when curb ramps or landing platforms have a vertical drop of 3 in. or more.
3. Detectable edging with a 6 in. minimum height and contrasting color shall be installed on all curb ramp landings where the walkway changes direction (turns).
4. Curb ramps and landings should have a 2% max cross-slope.
5. Clear space of 48 in. x 48 in. minimum shall be provided above and below the ramp.
6. The curb ramp walkway edge shall be marked with a contrasting color 2 to 4 in. wide contrasting color marking.
7. Impacts of temporary ramps on drainage shall be considered and their location should not result in ponding in the roadway that may result in a hazard.
8. Lateral joints or gaps between surfaces shall be less than 0.5 in. width.
9. Changes between surface heights should not exceed 0.5 in. Lateral edges should be vertical up to 0.25 in. high, and beveled at 1:2 between 0.25 in. and 0.5 in. height.

Temporary curb ramps may be pre-fabricated, or constructed on site using temporary materials such as plywood (with slip resistant material), bituminous concrete pavement, or compacted aggregate. All curb ramps, whether pre-fabricated or constructed in place shall meet the design requirements listed above.

5.2 TEMPORARY PEDESTRIAN SIGNALS

In some cases, it may be necessary to provide a temporary pedestrian signal as part of a TTC Plan. If providing a temporary pedestrian signal, it should include standard accessible features such as accessible pushbuttons as defined in the VTrans Standard Specifications for Construction section 752.14. The timing of the walk phase must be adequate to allow safe crossing by all users. Vulnerable pedestrian populations including children, senior citizens, and people with disabilities have slower walking speeds and if it is known that a crossing will likely serve these populations, additional time in the walk phase may be required.

5.3 PEDESTRIAN CHANNELIZING DEVICES (PCD) – SELECTION & PLACEMENT

Providing a well-delineated, accessible walkway is critical in guiding pedestrians safely and effectively through or around the work zone. If the temporary walkway is created using roadway or parking space (i.e. not using existing sidewalks) and pedestrians are being directed to a new path of travel, then Pedestrian Channelizing Devices (PCD) are required. Where PCD are used, they must have a continuous detectable top and bottom edge so that pedestrians with visual disabilities can detect them. The use of cones, barrels, or other intermittent devices with tape is not acceptable as a PCD. Examples of longitudinal channelizing devices and pedestrian barricades are shown below with proper dimensions and placement notes. Barricades are used to block off active work areas and may also be used as a channelizing device. Channelizing devices are used to define temporary walkways and to separate pedestrians from either construction activities or traffic. Additional information on channelizing devices can be found in the MUTCD Chapter 6F. Design details for channelizing devices and pedestrian barricades are provided in Appendix C of this document.

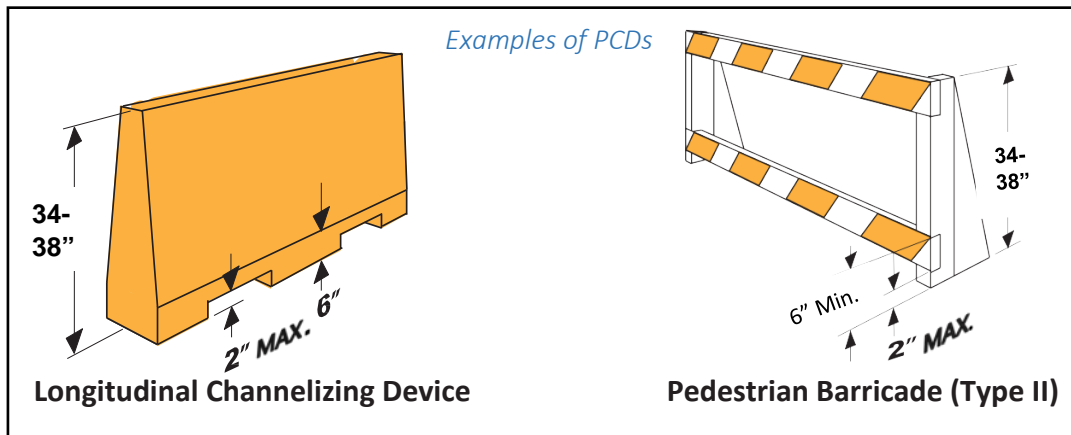

1. To prevent any tripping hazard to pedestrians, ballast shall be located behind or internal to the device.
2. The bottom edge of the bottom detectable edging shall be continuous and no greater than 2 inches above the walking surface and the top of the bottom edging should be at least 6 inches above the surface. PCDs should be orange, white, or yellow and consistent with adjacent devices.
3. Devices should not prevent the drainage of water from the walkway. An opening with a 2 inch maximum height above the walkway surface is allowed for drainage.
4. Longitudinal channelizing devices for pedestrians shall have a minimum height of 32 inches. Longitudinal channelizing devices shall not be installed with a handrail.
5. When hand guidance is required, the top surface of the device shall be in a vertical plane perpendicular to the walkway with a continuous height of 32 - 38 inches.
6. All devices should be free of sharp or rough edges with all fasteners installed below the surface and capped to prevent harm to hands, arms or clothing of pedestrians.
7. All devices used to provide guidance for pedestrians shall interlock to prevent gaps between devices.

5.4 TEMPORARY PATHWAY ALIGNMENTS

Where a TPAR is delineated with PCDs, they may be required on both sides. The PCD on the non-traffic side of the TPAR does not need to be crash-worthy, but the PCD separating pedestrians from adjacent traffic (if applicable) must be crash-worthy.

Use the following factors in determining accommodation plans for pedestrians:

- **Project Duration** – Longer projects may warrant a more comprehensive TTC Plan with several phases of traffic control, thereby justifying placement and cost of more substantial pedestrian control measures.
- **Vehicle and Pedestrian Volumes** – Work zones on high traffic volume facilities, facilities with transit service, and facilities with higher pedestrian volumes warrant more extensive plans for providing pedestrian access and safety.
- **Alternate Pedestrian Routes** – On-site alternate pedestrian routes are preferred over detours due to shorter lengths, consistent terrain, and accessibility. However, where staging impacts on-site routes, local detour routes may be available and can help decrease risks related to exposure to work activities. Both route options must provide for the protection of pedestrians, be properly signed, and accommodate users of all abilities.
- **“Outside the Box” Alternatives** – Occasionally, neither on-site pedestrian routes, nor local detours are viable. In these cases, more creative means of pedestrian transport should be

considered and weighed against traditional traffic control measures. Partnerships with public transit and shuttle services may provide acceptable levels of pedestrian mobility.

- **Available ROW Widths** – Where pedestrian facilities can be accommodated in proximity to the work area and existing facilities, consider including additional width as part of a construction easement. If widened, the additional width could be used for placement of temporary pedestrian facilities.
- **Benefit/Cost Ratios: Device Quantities vs. Other Measures** – While not a primary consideration, costs between measures must be compared and weighed in combination with other issues discussed above.
- **Assigning a Pedestrian Escort** – If it is infeasible to provide either a TPAR or pedestrian detour that is a reasonable length, it is allowable for contractors to assign someone the responsibility to assist pedestrians through the work zone. The person assigned these duties shall not be a flagger who is performing those duties.

5.5 DEVICE PLACEMENT

Placement of pedestrian channelizing devices will vary depending on a number of factors, including the location of pedestrians with respect to the hazard(s) – e.g. traffic, construction activities, surface conditions, work area hazards, etc.

- **Between Pedestrians and Traffic** – In cases where the project affects the existing pedestrian facility and pedestrians are provided access on the same roadway surface as motor vehicles (e.g. a closed lane or shoulder), an NCHRP-350 or MASH compliant crash-worthy barrier system (concrete, steel or plastic (water-filled)) on the roadway surface shall be used to separate vehicles from pedestrians.

Consider providing TPARs through a parking lot or similar areas by means of a construction easement or other agreements with property owners. Use PCD on both sides of the pathway to channelize these temporary pedestrian routes.

Do not specify “Work Area Fencing” to delineate temporary pedestrian routes, or to separate pedestrians from a work area.



Obsolete "Work Area Fencing" shall **not** be used as channelizing devices. This fencing does not provide pedestrians with adequate protection from work area activities or traveling vehicles and does not provide a continuous, detectable bottom edge.



Plastic, water filled barriers are an appropriate channelizing device for pedestrian facilities. PCD should be used on both sides of the pedestrian route when work area hazards or traffic are present on both sides of the roadway.

- **Between Pedestrians and The Work Area** – Use PCD between pedestrians and the active construction work area when the following conditions apply:
 - Pedestrian traffic must pass alongside the work area. The “work area” may include active or inactive work, the storage of equipment and materials, or empty space for contractor access/staging purposes.
 - If work area hazards are present on both sides of the pedestrian pathway, PCD should be placed on both sides of the pathway, as shown below.



Above, the pedestrian route is delineated on both sides to provide a physical barrier between the pedestrian and the work zone as well as between the pedestrian and vehicle traffic.

5.6 COVERED PATHWAYS

Where work activities are planned to take place above a pedestrian walkway (i.e. bridge work or on a building adjacent to a sidewalk) for an extended period, the TTC Plan shall include means to provide a covered walkway to protect from falling debris. Short-term closures of walkways and provision of

alternate routes shall be provided any time construction materials or operations occur over a pedestrian walkway. In no case shall active construction occur above walkways open to the public. It may be necessary to temporarily restrict pedestrian access while overhead work is occurring, but pedestrians shall never be exposed to overhead hazards.

Covered Walkway Design Elements

1. Specifications and drawings of the covered walkway must be stamped and signed by a Professional Engineer licensed in the state of VT.
2. Roofs of covered walkways shall be water tight and designed for adequate live loads.
3. Covered walkways shall have a clear and unobstructed ceiling height of not less than eight feet (8 ft).
4. Covered walkways shall have a clear unobstructed width of not less than five feet.
5. Covered walkways shall not allow unprotected passage along the sidewalk on either side of the covered walkway.
6. The interior of the covered walkway shall be lighted at all times. Lights shall be installed on the ceiling and provide an adequate level of illumination. Lights must be left on overnight. Lighting shall be inspected nightly and burned out or inoperative lights shall be replaced or repaired by the next business day.
7. The structural members of the covered walkway shall be adequately braced and connected to prevent displacement or distortion of the frame work.



A covered walkway protects pedestrians from construction dangers occurring above them including falling debris. Covered walkways shall be lit for nighttime use and include proper barriers along their alignment.

5.7 PATHWAY LIGHTING

Temporary pedestrian facilities should be adequately lit for nighttime use. Existing lighting may be used, but supplemental lighting may be needed for TPARs. Engineering judgement should be used to determine if additional lighting is needed. If the need for additional lighting is identified after work has begun (i.e.

via pedestrian complaint, incident, or otherwise) it shall be provided and installed as soon as is reasonably possible.

The National Cooperative Highway Research Program (NCHRP) Report 476 focuses on nighttime lighting for work zones and may be used as a resource for work zone lighting requirements. Lighting can mitigate factors such as slight changes in level or roughness of the walking surface that can cause trips and falls for pedestrians. Surfaces must be lighted in a way that does not conceal irregularities via shadows or light patterns.

The VTrans Street Lighting Design Guide (2015) and the NCHRP Report 476 should be used as the standard for lighting provisions for work zones. Note that requirements for work zones and pedestrian facilities may differ in these documents; if conflicting, the standard with the highest lighting provision shall be utilized. In any case, the method for achieving minimum illumination should be specified in the TTC Plan's lighting plan. Adequate nighttime lighting must also be provided for all temporary crosswalks. The VTrans Street Lighting Design Guide can be found at <http://vtrans.vermont.gov/docs#Guide>.

5.8 TEMPORARY SIGNING

Providing **appropriate, complete, and consistent** signing for TPARs is critical in helping to ensure effective pedestrian accommodation in a work zone.

Several standard signs are available for use in signing sidewalk closures, providing direction to crossing points or alternate routes and for pedestrian detours. Designers should use the following resources in developing their pedestrian traffic control sign plan details:

- FHWA Standard Highway Signs and its Supplement
- MUTCD
 - Part 2 – Signs
 - Part 6 – Temporary Traffic Control

In signing a temporary pedestrian facility, designers should focus on six important components:

- (1) **Notice of Closure:** When sidewalks are closed, clear signage is needed in advance of the closure. Signs shall be used together with PCD as an effective means for keeping pedestrians from venturing beyond the intended point of closure – especially critical where closure points are immediately adjacent to an active work area, or location that could result in significant injury or death for the pedestrian.
- (2) **Detectable Barrier:** PCD are also effective in providing a detectable barrier – a device designed to be detectable to visually impaired pedestrians. Audible signage may be required in addition to detectable barriers to guide visually disabled persons safely through or around the work zone. Audible signs may be utilized whenever detectable barriers are not continuous throughout the length of the work zone, and there is knowledge of visually impaired pedestrians in the area. It is best practice to always provide audible signs, but their use would be more imperative when it is known that an area is traversed by visually impaired pedestrians.
- (3) **Positive Guidance:** Through signing and devices, an alternate route must be conveyed to pedestrians. Without adequate, clear direction, pedestrians may choose their own route – a route that may lead them into conflict with construction activities. The use of standard signs, and those displaying regulatory messages is strongly recommended. Warning signs should be used to alert pedestrians of any changed conditions.

- (4) **Continuous Route Signing:** Adequate, clear pedestrian detour signing must be continued at reasonable intervals along the **entire** alternate route, for **both** directions. Confirmation signing may be needed at each intersection, or at key turns along the route. In some cases, multiple closure points may be necessary to construct a single, desired alternate route for pedestrians.
- (5) **Weather Conditions:** All signs and devices within and around a work zone shall be secured against weather related movement. This can be accomplished via sand bags, screwing down delineators to the pavement surface, or other appropriate means to ensure continuous proper placement of signs and channelizing devices. In the case of altered position or removal by weather or traffic, signs and delineating devices shall be returned and secured to their proper position as soon as reasonably possible.
- (6) **Location:** Work zone signs should never obstruct existing facilities. Signs obstructing sidewalks that would otherwise be open to the traveling public shall not be used. An example of unacceptable sign placement is shown below.



The above sign places the pedestrian in immediate danger by forcing the pedestrian onto the roadway to navigate around the work zone warning signs. This type of sign placement shall not be used.

Below are examples from the MUTCD regarding pedestrian traffic control in work zones. Specific details on the signs including size and suggested placement can be found in Part 6 of the MUTCD. Sign details are in the Standard Highway Signs Book. Pedestrian detours and diversions are shown. Whether a detour or diversion is used is at the discretion of the designer pending available facilities and physical characteristics of the roadway and surrounding area. In the following figures, only traffic control devices controlling pedestrian movement are illustrated. Additional traffic control devices may be needed to control vehicular traffic on the roadway.

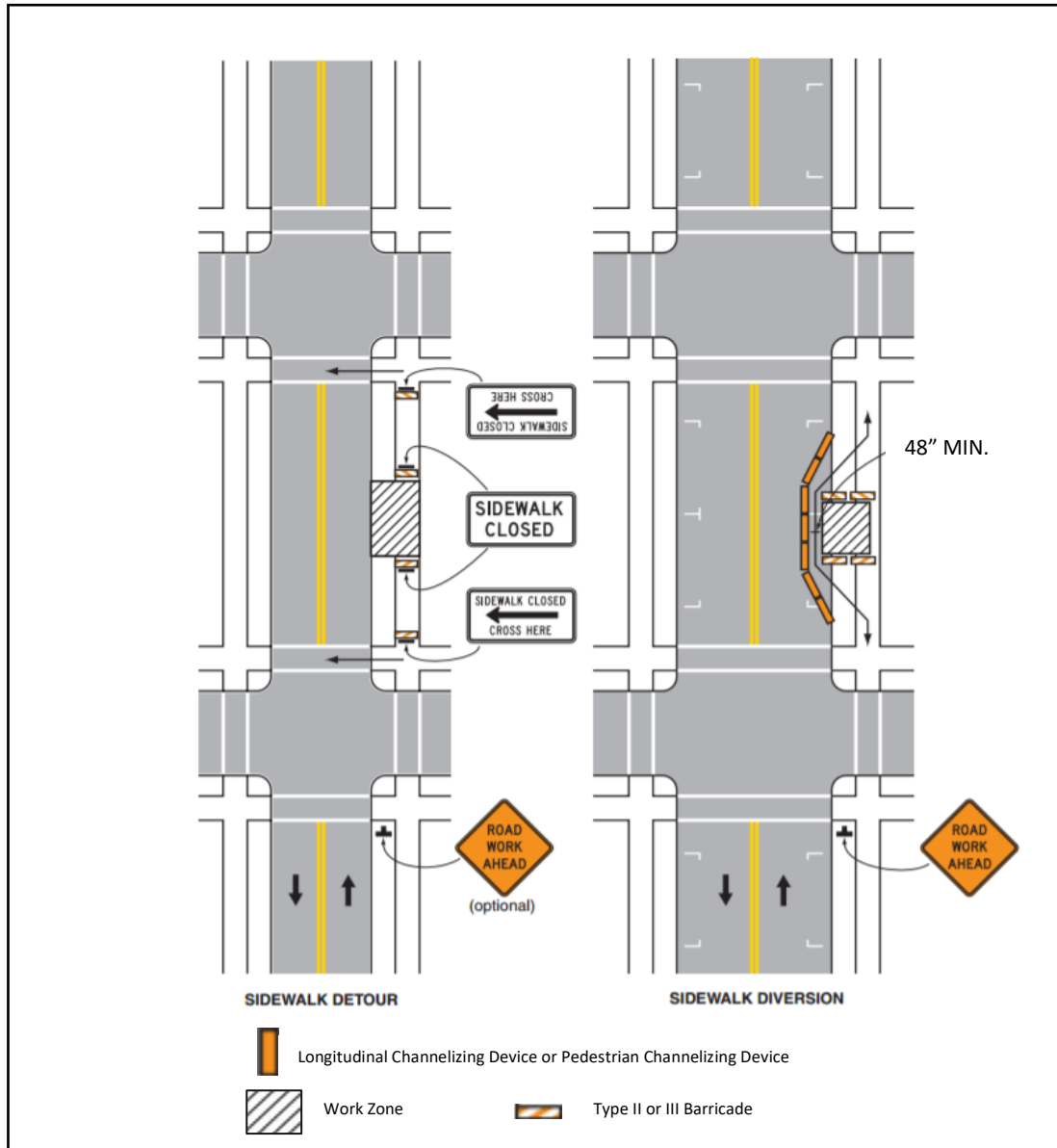

Typical Application 28 from the 2009 MUTCD demonstrates two options for accommodating pedestrians when a sidewalk is closed, a sidewalk detour and a sidewalk diversion. When a sidewalk is present on only one side of the roadway, a sidewalk diversion is the preferred treatment for pedestrian accommodation.

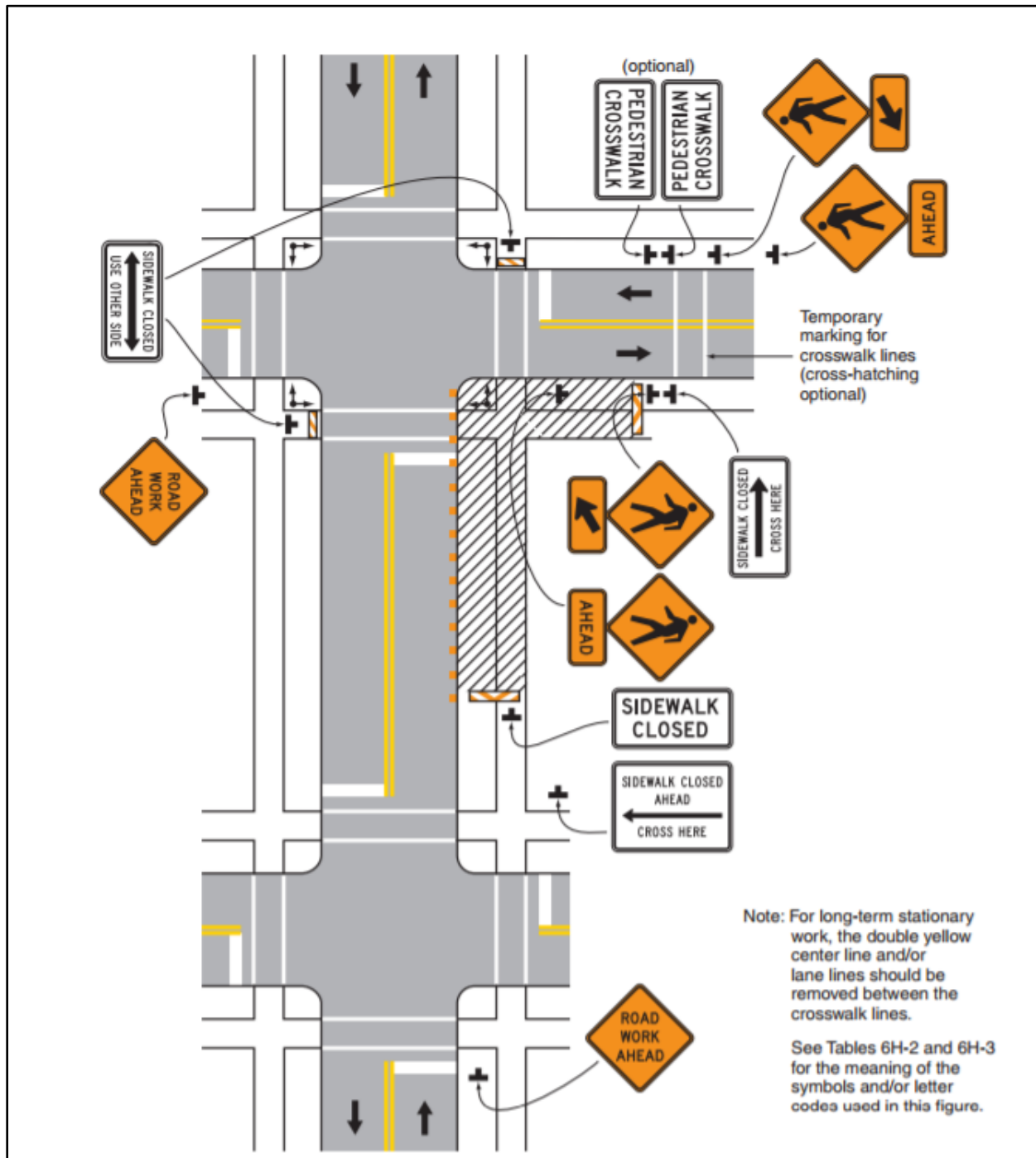

Typical Application 29 from the 2009 MUTCD demonstrates pedestrian accommodation using a temporary mid-block crosswalk as a pedestrian detour.

When existing site conditions make it infeasible to meet the recommended standards for pedestrian accommodation, these conditions shall be documented and maintained in the project files. Conditions may include insufficient width, traffic conflicts, steep grades, etc. The TPAR provided must still meet accessibility requirements to the maximum extent feasible.

The TTC Plan should include bid items and quantities necessary to implement the details shown in the plans. Special Provision 900.645 (Maintenance of Pedestrian Traffic) is available and provides a means to pay for temporary traffic control including channelizing devices, temporary pavement markings, signs, temporary curb ramps, handrails, and detectable warning devices. This special provision provides a lump sum bid item for all materials, installation, relocation, and removal required for maintaining pedestrian traffic through the work zone.

5.9 WORK ZONE DESIGN FOR CONSTRUCTION IN AREAS WITH NO SIDEWALK

In cases where a new sidewalk is being installed, and no pedestrian facility is being closed, it is still important to be aware that pedestrians may utilize the area for travel, and may need some level of accommodation. At a minimum, if the project area is known to have pedestrian traffic, the overall TTC Plan should discuss how pedestrian travel through the work zone is to be treated. While not required when there is no existing facility, designers should consider providing a temporary walkway through the work area so that pedestrians know where to go and are protected from construction activities and adjacent traffic.

For areas where pedestrian use is low, but not restricted (like it would be on a limited access highway), there are still some basic considerations for the occasional pedestrian that may come across the work zone. Contractor's personnel can be assigned the responsibility to escort those pedestrians through the work zone to make sure that they can do so safely, without being exposed to hazards from traffic or construction operations. Flaggers shall not be assigned this as an extra duty.

In either case, if pedestrian traffic is expected, it is recommend that the project plans include the Pedestrian Temporary Traffic Control Notes that have been developed by VTrans and are available here - <https://vermontgov.sharepoint.com/sites/VTRANS/VTransIntranetHome/Highway/Ops/TSMO/Shared%20Documents/Forms/AllItems.aspx>.

5.10 ROAD CLOSURES

Where a road that includes pedestrian facilities or is known to be used by pedestrians is closed, it may be necessary to include a provision in the contract to shuttle pedestrians from one side of the closure to the other. When considering whether this is the correct treatment, designers should consider the length of detour that a pedestrian would have to walk and the anticipated volume of pedestrians. If a sidewalk is impacted by the closure and the detour is excessive, a shuttle should be provided. In consideration of what length detour is excessive, keep in mind that the average pedestrian trip is ½ mile in length.

6. WORK ZONE DESIGN FOR BICYCLISTS

When a work zone affects the safety, accessibility, or movement of bicyclists, the TTC Plan shall provide traffic control measures to accommodate bicyclists through or around the work zone. Generally, for more rural sections of road with no specific bicycle facility (e.g. a marked bicycle lane or shared use path), TTC Plans for motor vehicle traffic will also serve bicyclists without much additional work or modification. Bicycle volumes should be researched prior to designing the TTC Plan and/or observed prior to the commencement of work to determine the need for specific bicycle facilities through the work zone. Municipalities, Regional Planning Commissions, VTrans, and other similar resources may be helpful in determining the likelihood of bicycle presence on particular roadways.

The VTrans Bicycle Corridor Priority Map can be found in Appendix A of this document. These priorities were determined as part of the VTrans On-Road Bicycle Plan. Data from this plan (found here: <http://vtrans.vermont.gov/planning/bikeplan>) should be used by designers and contractors as part of the available data to determine the potential presence of bicycles on roadways.

If the existing roadway to be affected by the project includes a marked bicycle lane or if the highway is a signed bicycling route (e.g. the Cross VT Trail or Lake Champlain Bikeway), bicyclists should be provided with a convenient facility that replicates, as nearly as practical, the most desirable characteristics of the existing bicycle facility (i.e. pavement markings, physical delineation, signs).

The continuity of a designated bikeway should be maintained through the work zone whenever possible. The continuity of the bikeway is especially important where bicyclists have been traveling on a shoulder, bike lane, or shared use path adjacent to a high speed (> 35mph) motorized vehicle travel lane. There is a safety concern if bicyclists were to share the travel lane with motorized vehicles through the work zone on these high speed roadways, specifically if a speed reduction is not applied to vehicular travel lanes. If available, a reasonable detour route on a lower speed roadway is preferred over extended lengths of shared lanes on high speed roadways, even if it means some out of direction travel.

6.1 BICYCLE ACCOMMODATION PRINCIPLES

The principles discussed in the VTrans Work Zone Mobility Guide and the MUTCD Part 6 all apply to accommodating bicycles in a work zone with regard to advance notice, use of devices and dimensions. For site-specific conditions or configurations not addressed in those references, the TTC Plan designer should provide additional bicycle-specific details within the TTC Plan.

- Do not lead bicyclists into conflicts with motorist traffic, construction vehicles, equipment, operations or hazardous materials.
- Provide a convenient and continuous bicycle facility with an equal or better degree of bicycle accommodation than the existing facility being disturbed.
- On-road bicyclists should not be directed onto a path or sidewalk intended for pedestrian use except for shared-use paths of adequate width or where no practical alternative is available.



- If possible, the preferred treatment is to provide separate roadway space (e.g. a minimum 4-foot-wide shoulder or bicycle lane) for bicyclists through work zones. A shoulder or bike lane should be provided on corridors with traffic volumes greater than 5000 AADT or with posted speeds (or construction posted speeds) of 40 MPH or greater. If those conditions exist, channelizing devices shall be used to separate bicycles from traffic if delineating a long-term temporary bicycle facility. Channelizing devices may be used for intermediate or short-term duration work zones.
- For posted speeds during construction of 35 mph or lower, where neither roadway width, nor alternate routes are available, a “shared roadway” condition may be adequate. If the project impacts an existing bike lane or signed bicycle route, the Bicycle warning sign (W11-1) and “Bicycles ON ROADWAY” plaques shall be used to increase awareness of the shared road condition.
- Dismount zones are strongly discouraged as a form of bicycle accommodation. Only in extreme cases where no other option is available should bicycles be forced to dismount to use a pedestrian facility.

6.2 BICYCLE DETOURS

Where an existing bicycle facility is impacted, and roadway width is not available to provide adequate bicycle facilities through a work zone, or where it has been determined that doing so would raise a significant safety concern based on existing vehicle speeds or volumes, detour routes should be considered for bicycle accommodation.

In considering potential detour routes for bicycles, several conditions shall be considered including length, grade, shoulder width, and surface condition of the alternate route. Bicycle detours should utilize existing, nearby bicycle facilities or low volume roads wherever possible. A detour that parallels the existing facility is ideal, but not always possible in rural areas. Engineering judgment shall be used in consideration of the above factors to determine if a detour is reasonable. Designers should consider that the average length of a bicycle trip in the U.S. is approximately 2 miles.

If a detour route is sought, it shall be well documented within the TTC Plan and have a signing plan in place. Coordinate with local agencies if detours are planned on their facilities (i.e. local roads or paths that are not part of the State network). Ensure bicycle traffic and any sign and channelizing device placement on their facilities are approved prior to the project being released for advertisement. Regulatory bicycle exclusion signs may be used to keep bicycles out of the work area and encourage use of the detour route.

If a detour is being provided for all traffic and it makes use of limited access highways where bicycle traffic is not allowed, a separate, signed detour route for bicycles shall be provided. Signs for the main detour route shall clearly indicate that it is not the intended route for bicycle traffic. Public outreach about both detours should also clarify the distinction between the two routes.

The TTC detour plan for the bikeway should include necessary advance warning signs (W-21 series) and detour signs (M4-9 series), as well as any other temporary traffic control devices necessary to guide bicyclists along the detour route.

Public notice for bicycle detours should be posted in advance of any closures. Notice can be posted on project and/or town websites, Front Porch Forum, at local bike shops, etc. to provide advanced warning of affected bicycle routes.

6.3 FLAGGERS

Flaggers can be utilized to aid in bicycle traffic control in work zones where a shared lane configuration exists and traffic is maintained in an alternating one-way pattern. All on-site flaggers should be aware of the TTC Plan's accommodation for bicyclists. It is current best practice to clear the vehicles from an approach first, while bicycles remain halted. Once the vehicles have cleared the queue, or at the flagger's halting of the queue, bicycles will proceed to travel through the work zone. This practice separates the through movements of vehicles and bicycles so that they are not competing for the same space and shall be used when the lane width is 11 feet or less and no dedicated bicycle facility is provided through the work zone. If separate roadway space is provided for bicyclists (i.e. a shoulder or bike lane), they may proceed together with motorized traffic.

6.4 "OUTSIDE THE BOX" ALTERNATIVES

Occasionally, neither on-site roadway width, nor local detours are available. In these cases, more creative means of accommodating bicycles should be considered and weighed against traditional measures. When a reasonable bicycle detour route cannot be determined, a shuttle service or other alternative transport may be provided to safely transport bicyclists around the work zone. Consider temporary bus/shuttle stops, information kiosks, "hotline" phone numbers, etc. to provide an effective transportation means for bicyclists on significant cycling routes.

Coordination with cycling events (e.g. The Vermont Challenge, triathlons, "Bike to School Day" events etc.) is essential when construction is occurring on planned event routes to ensure safety of contractors and event participants. This coordination may include event detours, or a special construction schedule to provide adequate, safe surfaces for cyclists.

6.5 TEMPORARY SIGNING

Bicycle-specific signing shall be used any time construction disrupts a designated bike lane or shared use path. Specific signing may be used when a signed bicycle route (e.g. the Cross VT Trail or Lake Champlain Bikeway) is impacted by construction.

Signing within the work zone should be clear and consistent for the entire length of the work area. The placement of temporary signs should be designed so as not to disrupt traffic flow, and to be easily visible to all users.

The BICYCLES MAY USE FULL LANE (R4-11) sign should be used when the following conditions exist:

- Roadways and street with a construction speed limit of 35 mph or less
- Where the combined travel lane and usable shoulder width is less than 14 feet

The BICYCLES MAY USE FULL LANE sign should **not** be used on unmarked, undivided roadways.

Include the bicycle warning sign (W11-1) for the conditions described above, and for locations and situations such as:

- Shoulders or bike lanes are closed or removed as part of construction activities
- Designated Bicycle Routes: Several highways in Vermont are signed as long-distance bicycle routes.

Temporary signing can also be helpful in identifying the location, or beginning and ending points of a temporary bicycle facility. Temporary warning signs as well as regulatory bicycle traffic control signs may be useful in safely guiding bicycles through or around work zones. While standard sign designs should be considered first, project-specific sign designs may be necessary. Bicycle-specific work zone sign details have been provided in Appendix C of this document.

The below sign packages focus on bicycle specific traffic control devices. Signs, lines, and other traffic control devices for vehicular traffic may also be necessary and shall conform to the standards outlined in the latest version of the MUTCD.

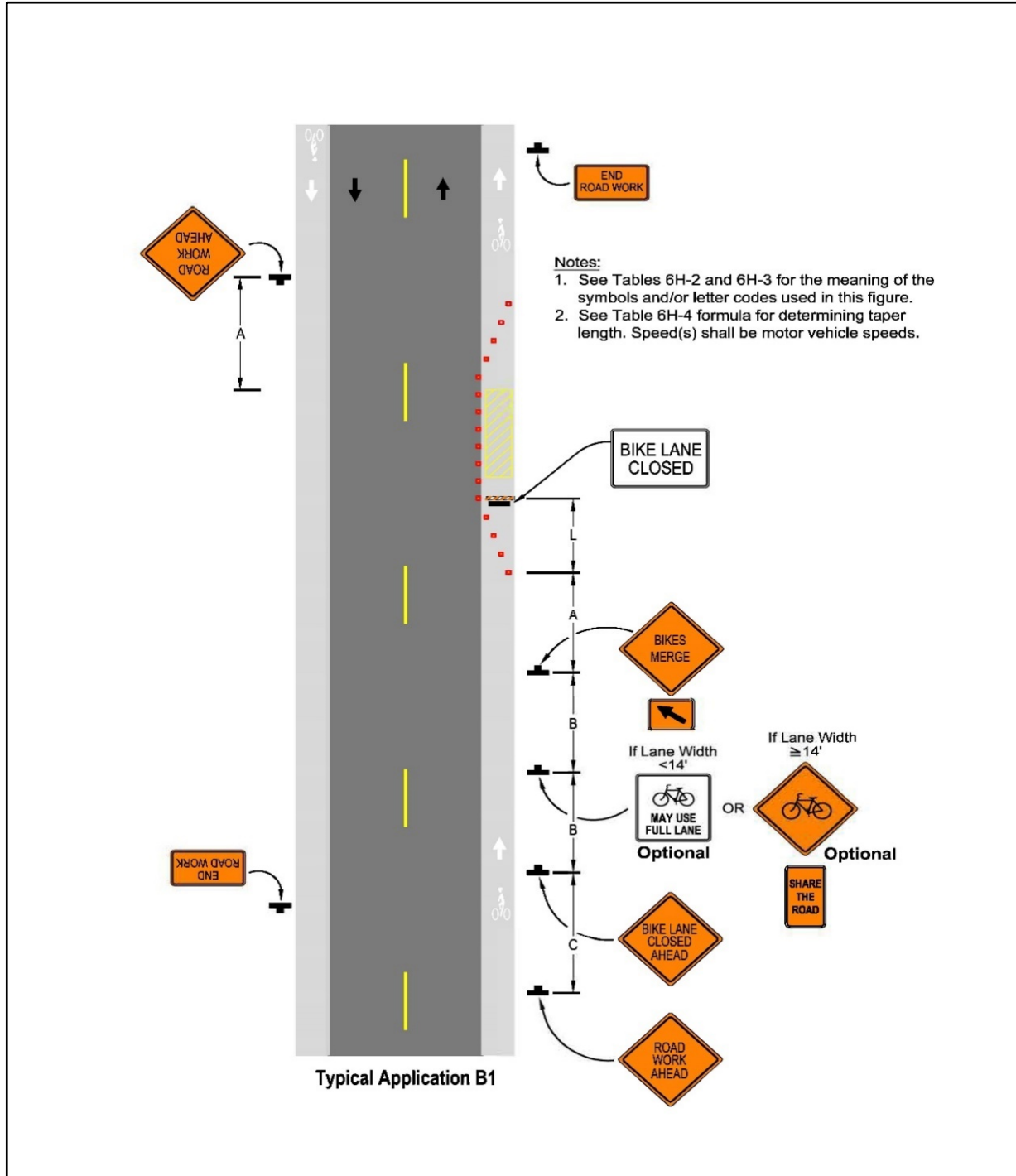

Typical Application B1 illustrates a closure of a bike lane where bicycle traffic is expected to share the travel lane with motor vehicles.

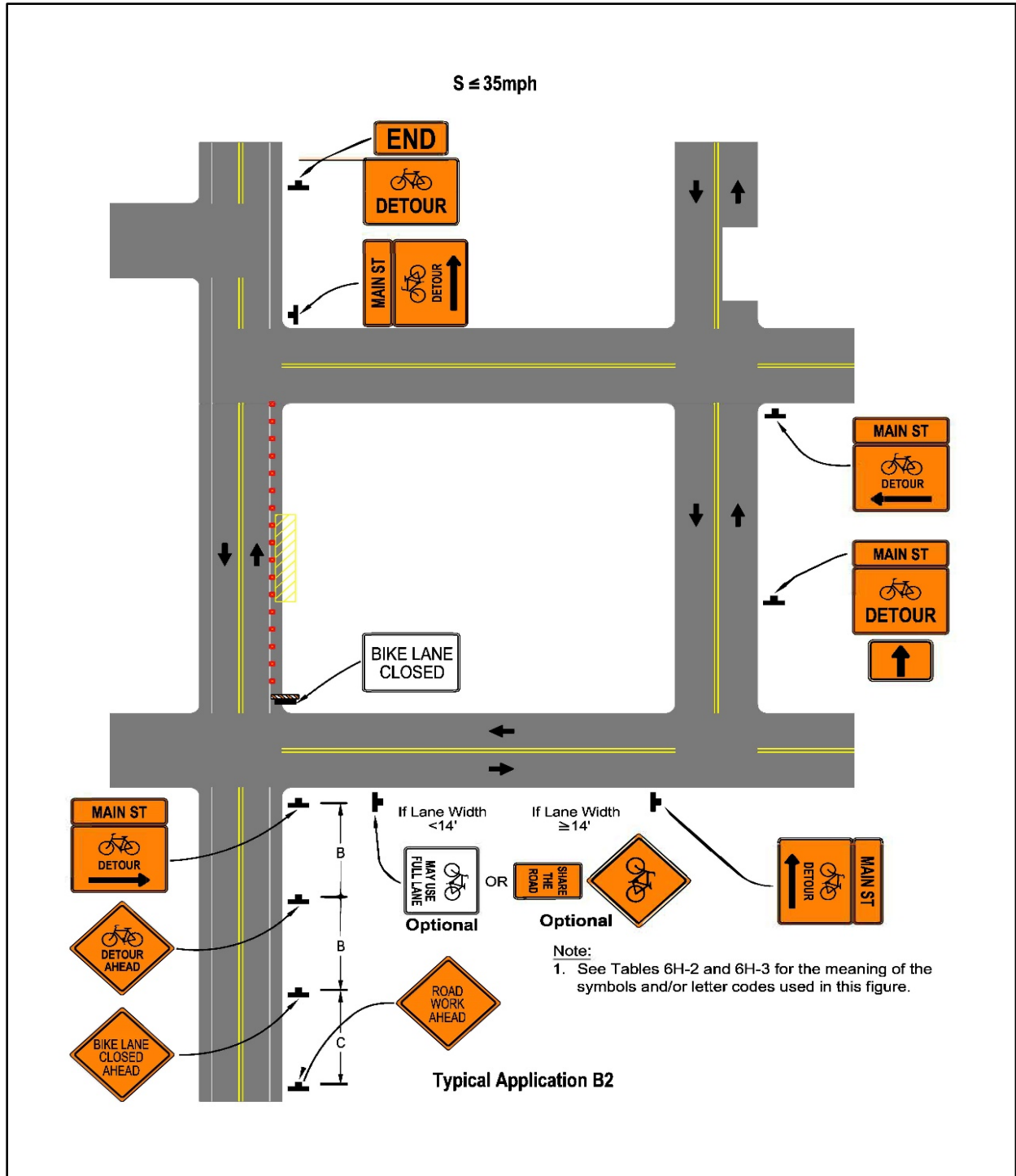

Typical Application B2 illustrates a closed bike lane and a signed bicycle detour.

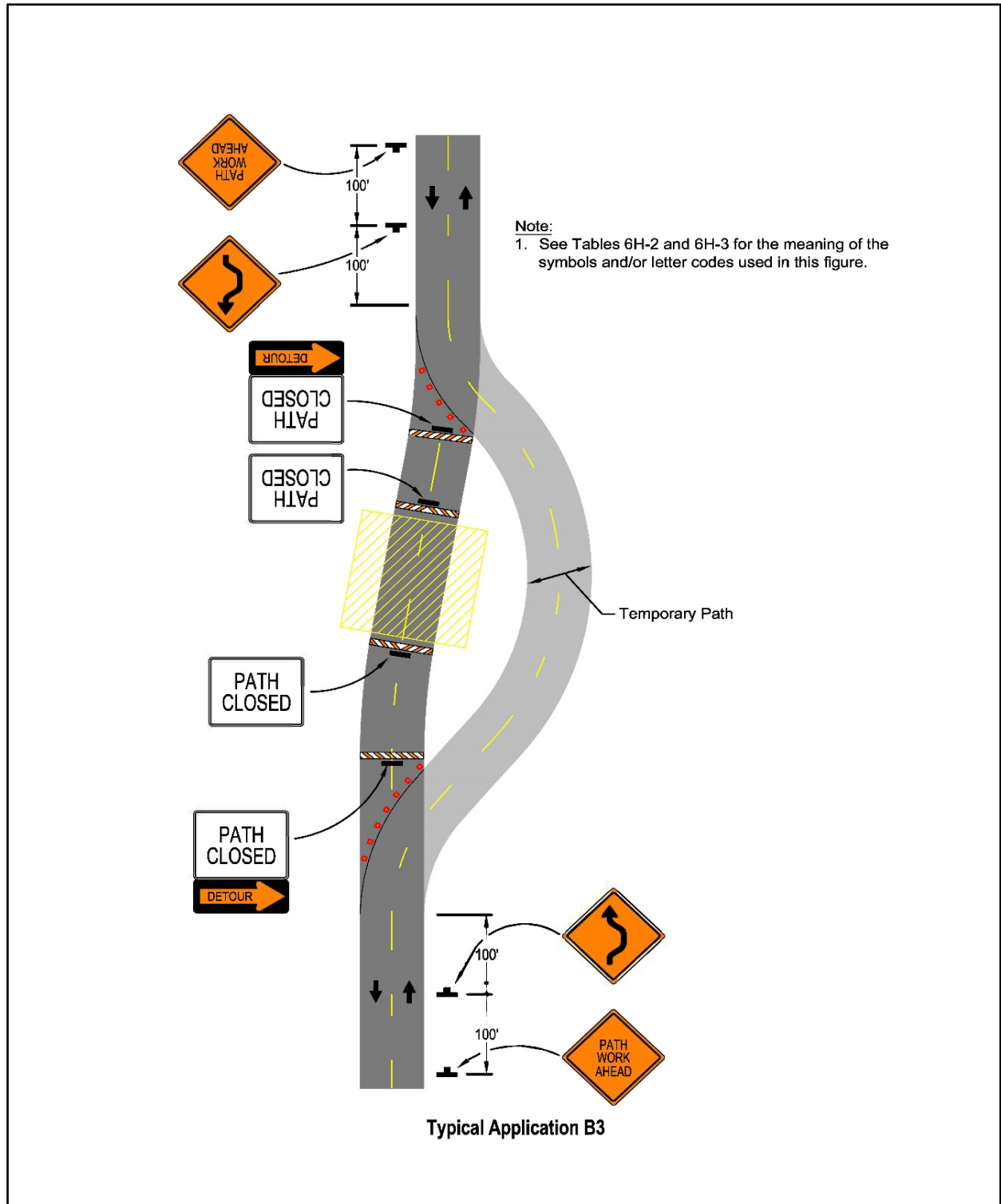

Typical Application B3 illustrates a closure of a shared-use path with the provision of a temporary path to provide continued access.

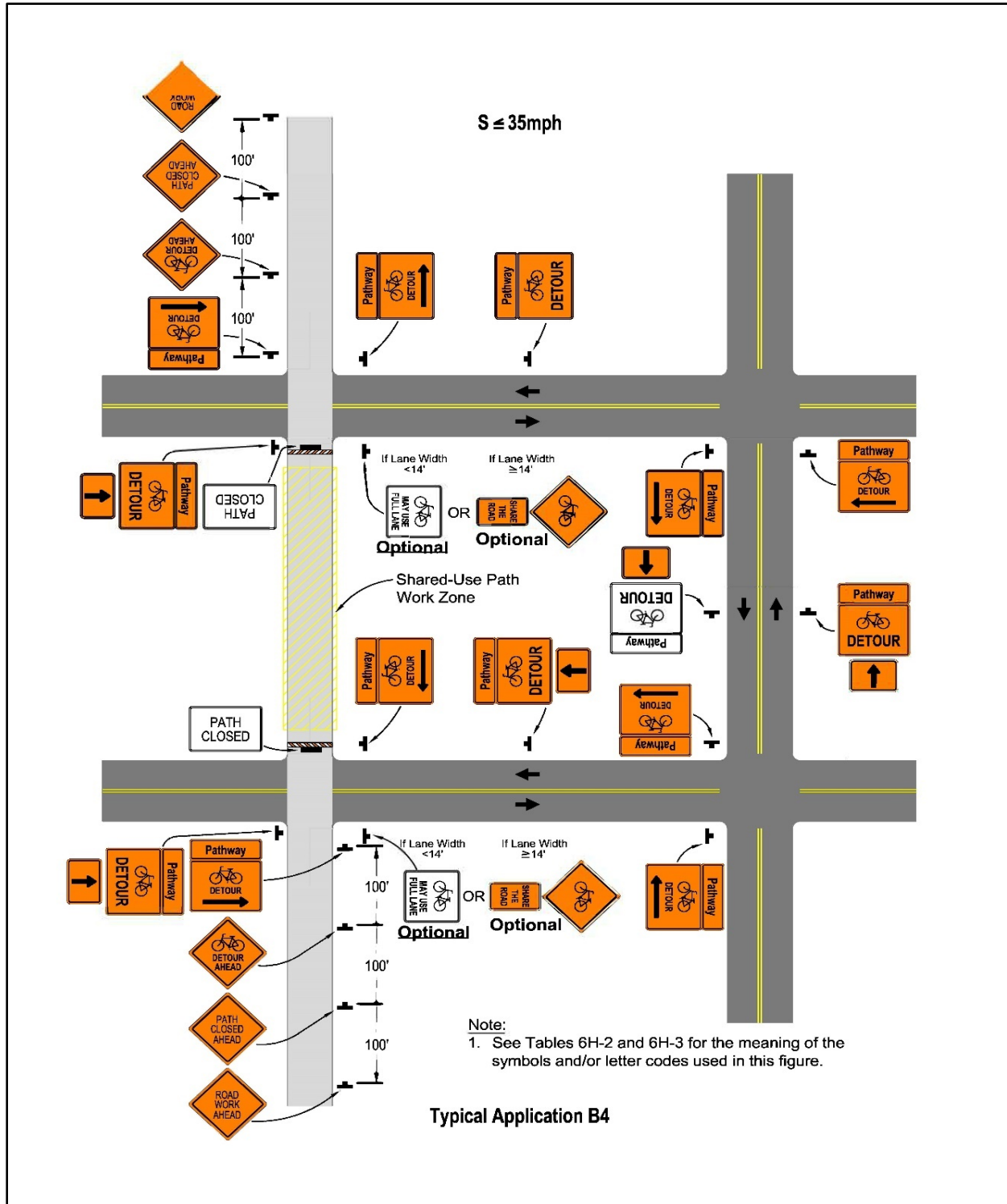

Typical Application B4 illustrates a closure of a shared-use path with the provision of a signed bicycle detour.

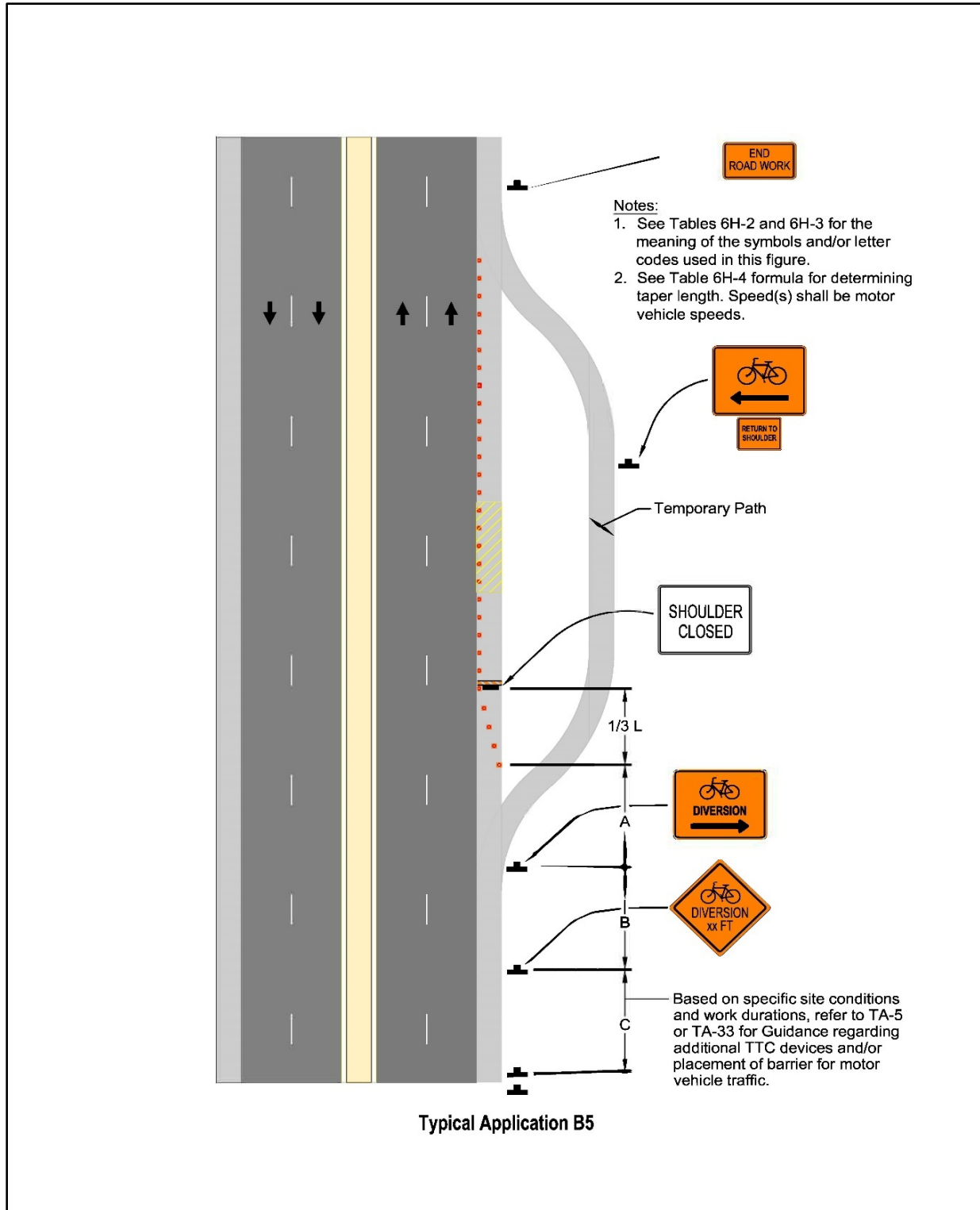

Typical Application B5 illustrates a closure of a bicycle lane with the provision of a temporary path to provide continued access.

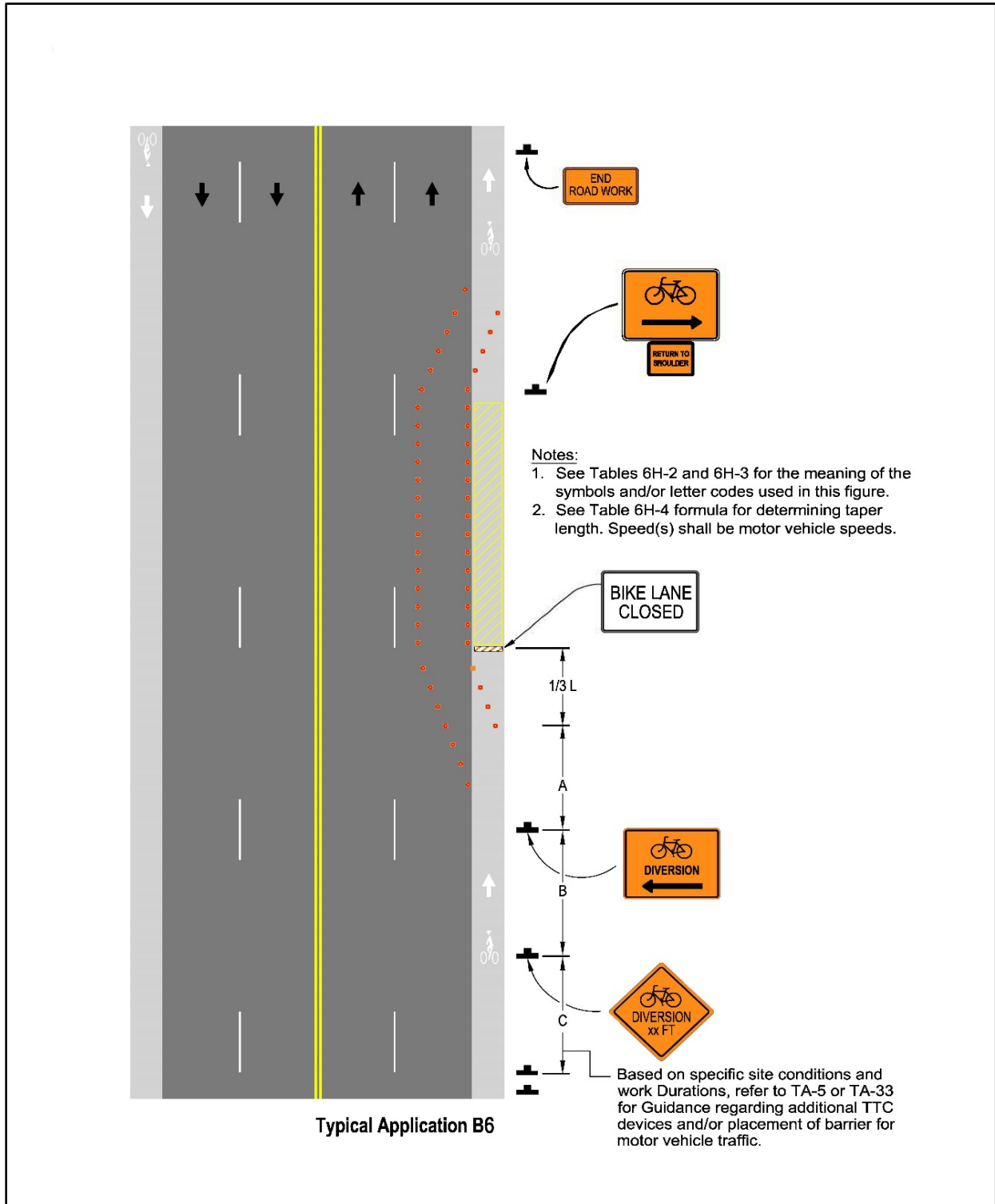

Typical Application B6 illustrates a closure of a bicycle lane with the provision of a temporary bike lane with delineation on the adjacent roadway.

6.6 CHANNELIZING DEVICES

Where a shoulder or bike lane of 4-feet or more is to be maintained between a traffic lane and the work area, designers should show enough detail on TTC Plan sheets to clearly convey the proper location of channelizing devices that will separate bicycle traffic from adjacent vehicle traffic and from the work area (if channelizing devices are being used.) Devices immediately adjacent to the work area (e.g. longitudinal saw cut, excavation, pavement overlay edge, etc.), should be located to optimize the width of the shoulder for bicycle traffic.

Include adequate numbers of cross-section details to emphasize the proper placement of devices with respect to the bicycle travel space. Designers should include additional notes or details to clarify the intent of how bicycles are to be accommodated in the work zone. Comments such as “Work zone will remain passable to bicycles at all times” are not acceptable.

As the required level of detail for bicycle and pedestrian accommodation is often higher and more site-specific than it is for motor vehicles, there is a benefit of designers providing bicycle-specific details on the TTC plan sheets.

6.6.1 BICYCLE CHANNELIZING DEVICES (BCD)

Bicycle Channelizing Devices (BCD) may be included in the TTC plan and placed between bicycle traffic and the active work area and/or between bicycle traffic and adjacent vehicle traffic. Depending on what is used for a BCD and site-specific conditions, an end treatment may be needed to ensure the BCD is not a hazard for vehicle traffic. BCD are not required to provide detectability as with PCD, therefore it is acceptable to use cones, flexible delineators or barrels. A clear width of at least 4 feet must be provided from the edge of any BCD to the edge of pavement or other physical object such as a curb or face of guardrail.

Below is an example of an unacceptable scenario where bicycles are entering an unmarked shared lane situation without any channelization or signage, and work zone hazards are present to their immediate right, followed by an example of appropriate device selection and placement.



No channelizing devices are provided for cyclists, forcing them to squeeze between the work area and the travel lane for motor vehicles. No signage or bicycle specific accommodations are made.



Channelizing devices are used above to separate bicyclists from vehicle traffic. Barricades are also used to separate bicyclists from work area hazards. Note that a combination of BCDs can be used to enhance visibility, separation, and mobility of bicycles as shown above.

The intent of the BCD is to guide bicyclists along a designated path and encourage them to stay on the roadway and out of the active work area. BCD are placed on the right of a bike lane/shoulder where it is necessary to separate bicyclists from active work areas. BCD are placed to the left of a shoulder/bike lane where traffic speeds and volumes indicate that positive separation between bicycle facilities and travel lanes is needed (see Section 6.1.)

Where a temporary bicycle facility differs from the motor vehicle alignment, BCD placement along the edge of the active work area should be considered. Additional BCDs may be placed on the opposite side of the temporary bicycle pathway to facilitate bicycles entering and exiting the temporary bicycle pathway.

In cases where work zone activities on the roadway occur in proximity to shared use paths, rail trails, or similar facilities, additional flaggers and traffic control management may be required. In areas where these facilities intersect state highways, it should be expected that bicycle and pedestrian volumes will be significantly higher and more frequent than other portions of the roadway.

7. SHARED USE PATHS

Shared use paths present a unique traffic control challenge: ensuring safe travel for both pedestrians and bicyclists. If a shared use path is impacted by construction, guidance through the work zone must be provided for all shared use path users, which may include: pedestrians, bicyclists, in-line skaters, joggers, etc. of all ages and abilities. When a shared use path is closed, pedestrians and bicycles may need to be diverted differently- e.g. pedestrians to the nearest sidewalk and bicyclists to the nearest bike lane. The alternative facility provided for pedestrians must meet accessibility requirements as described in section 5 of this guide.

Another alternative is to provide a temporary path that replicates the features of the path being impacted. With a temporary path, if it is provided using adjacent road space like a parking or travel lane, proper

channelizing devices must be used to separate the path from adjacent traffic. Because pedestrians use shared use paths, the channelizing devices must meet the detectability requirements of a PCD.

When detours are unavoidable, the shortest and most direct route as possible shall be used to safely guide pedestrians and bicyclists around the work zone. Any pedestrian detour shall meet accessibility requirements.

Using the principles and tools outlined for both pedestrians and bicyclists, a TTC Plan for a shared use path closure should be developed. If path users are directed to sidewalks and on-road bicycle facilities, it will be especially important to provide clear route signing for both user groups.

Another unique challenge for a TTC Plan for a shared use path is that paths serve bicycle traffic going both directions on one side of the road. If bicycle traffic is to be diverted onto a roadway to existing shoulders or bike lanes, careful attention must be paid to the transition from path to road and vice versa.

8. OTHER CONSIDERATIONS

The following represent unique environments that designers should be aware of as they begin their TTC Plan designs for bicycle and pedestrian accommodation. Each traffic control measure or work zone condition must consider the needs of bicyclists and pedestrians, or at least identify an alternative means to do so.

- **Temporary and Portable Signals:** Temporary pedestrian signals may be required to regulate temporary crossings on some roadways, especially for long-term work zones. These signals should include accessible pushbuttons and an accessible pedestrian path.
- **Impacts to Existing Pedestrian Signals:** If a crosswalk is closed at a signalized intersection, each applicable Pedestrian Crossing Signal Head should be covered, the existing push-buttons disabled, and the crossing itself should be signed and include detectable channelizing devices for any TPAR that is provided.
- **Urban/Suburban Intersections:** The scope of work for intersection improvements often includes work on all four corners of an intersection(s). In some urban/suburban environments, viable detours, or the location for adequate temporary facilities, may be limited. Consider the use of construction easements to provide the additional space needed to include a temporary pedestrian facility adjacent to the work area – one that would minimize out-of-direction travel and continue to provide good access and safety for pedestrians.
- **Construction Details and Staging Considerations:** TTC plans should provide enough detail to allow for the construction of the project, but also accommodate bicycles and pedestrians. For intersection projects, in particular, the TTC plan should break up intersection work into stages that will minimize out-of-direction pedestrian and bicycle travel. To meet this goal, only one corner of an intersection should be affected at a time.
- **Plan Sheets:** Plans should be developed specifically for pedestrian and bicycle accommodation at a larger scale (e.g. 1"=50') and should include details for:
 - Location of temporary curb ramps
 - Channelization
 - Closure points
 - Detour routes

- Surfacing design
- Widths of temporary pedestrian or bicycle facilities

For more information on addressing the needs of pedestrians and bicyclists in Work Zones or development of TTC Plans, contact:

Jon Kaplan, P.E.

Bicycle & Pedestrian Program Manager

VTrans Municipal Assistance Bureau

Jon.kaplan@vermont.gov

(802) 498-4742

Nancy Avery, P.E.

Work Zone Traffic Management Engineer

VTrans Traffic Systems Management and Operations

Nancy.avery@vermont.gov

(802) 279-5991

References

- Pedestrian Accommodation in Work Zones: A Field Guide (February 2018)
<https://www.workzonesafety.org/publication/pedestrian-accommodation-in-work-zones/>
- City of Seattle Traffic Control Manual for In-Street Work (2012)
<https://www.seattle.gov/transportation/tcmanual/2013/Traffic%20Control%20Manual%20FINAL%202012.pdf>
- FHWA Course on Bicycle and Pedestrian Transportation – Lesson 12: Pedestrian and Bicycle Facilities in Work Zones
https://safety.fhwa.dot.gov/ped_bike/univcourse/pdf/swless12.pdf
- Manual on Uniform Traffic Control Devices (and Revisions) (2009)
<https://mutcd.fhwa.dot.gov/index.htm>
- Oregon Department of Transportation Traffic Control Plans Design Manual – 12th Edition (2016)
http://www.oregon.gov/ODOT/HWY/TRAFFIC-ROADWAY/Pages/TTC_PLAN_manual.aspx
- United States Access Board Guide to the ADA Standards:
<https://www.access-board.gov/guidelines-and-standards/buildings-and-sites/about-the-ada-standards/guide-to-the-ada-standards>
- United States Access Board Proposed Right-of-Way Accessibility Guidelines:
<https://www.access-board.gov/guidelines-and-standards/streets-sidewalks/public-rights-of-way/proposed-rights-of-way-guidelines>
- Virginia Department of Transportation Work Zone Pedestrian and Bicycle Guidance (2016)
http://www.virginiadot.org/business/resources/wztc/2016_WZ_Ped_BikeGuide.pdf
- Work Zone Safety and Mobility Guidance Document- Appendix A (VTrans) (2011)
<http://vtrans.vermont.gov/docs>

APPENDIX A – BICYCLE CORRIDOR PRIORITY MAP



VTRANS BICYCLE CORRIDOR PRIORITY

Bicycle Use Categories

	Low Use / Priority	744 miles (30.8%)
	Moderate Use / Priority	784 miles (32.4%)
	High Use / Priority	890 miles (36.8%)

- | | | |
|--|--|--|
| | | |
| | | |
| | | |
| | | |
| | | |
| | | |

This map is the result of significant public participation and reflects the current and potential bicycle use on Vermont state roads. The map will be used by VTrans to prioritize improvements in projects and maintenance activities. For more information about the VTrans On-Road Bicycle Plan and how bicycle use was quantified, visit the project webpage (<http://vtransplanning.vermont.gov/bikeplan>).

COMPILED BY THE VERMONT AGENCY OF TRANSPORTATION POLICY, PLANNING & INTERMODAL DEVELOPMENT DIVISION MAPPING SECTION

MONTPELIER, VERMONT 05633

MARCH 2016

1:200,000

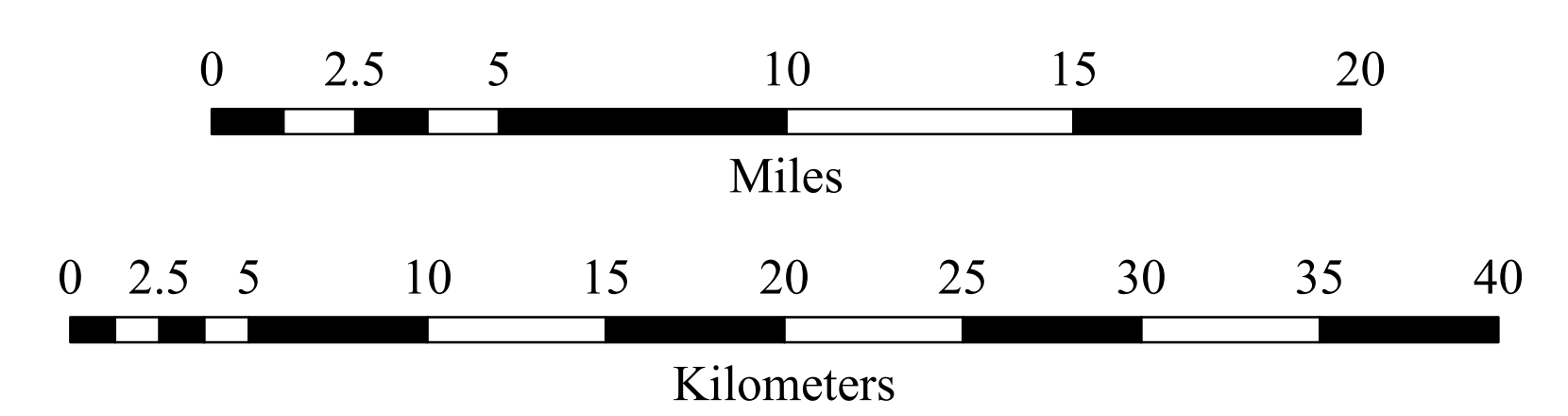

APPENDIX B – PEDESTRIAN AND BICYCLIST TTC CHECKLIST

VTrans Pedestrian and Bicyclist TTC Checklist

Project Name:			
Designer:			
PEDESTRIANS			
	YES	NO	Explanation for "NO" responses
General			
1. Is an existing sidewalk or shared use path going to be impacted by construction? If YES – A Temporary Pedestrian Access Route (TPAR) must be provided. If NO – Ensure that pedestrians are not exposed to construction hazards (equipment, materials, etc.) – At a minimum use TPAR standard notes.			
Signs			
2. Does the Temporary Traffic Control (TTC) plan include adequate construction approach signs? (sidewalk closures, advance notice of closures, temporary crosswalk signs, pedestrian detour routes)			
Barricades			
3. Are detectable barricades called for at the location of closures or to separate pedestrians from active work areas or traffic?			
Pedestrian Channelizing Devices (PCD)			
4. If the TPAR will be created using a portion of roadway, parking area or other area that was not existing sidewalk, are PCD called for?			
5. Do PCDs have a continuous bottom edge and a top rail that is 34" – 38" off the ground?			
TPAR			
6. Is the TPAR clearly delineated on TTC plans?			

	YES	NO	Explanation for "NO" responses
7. Is the "Clear width" a minimum of 48"? (60" preferred).			
8. If TPAR is 48", is a 60" X 60" passing area provided at least every 200 FT?			
9. Are there temporary curb ramps provided where applicable?			
Detours			
10. Has the length of pedestrian detours been minimized (preferred to provide access on the same side of street as the sidewalk closure)?			
11. Is the detour signed adequately in both directions?			
Overhead Work			
12. If overhead work is occurring over an existing or temporary pedestrian route for a long duration, is a covered walkway provided?			
Temporary Pedestrian Signals			
13. Are all accessible pedestrian features included on any temporary ped signals (locator tone, walk signal tone, accessible push button, etc.)?			
Lighting			
14. Is existing lighting adequate for nighttime use of the TPAR? Provide additional lighting as required by NCHRP 476 Guidelines.			
Miscellaneous			
15. If very limited pedestrian traffic is anticipated, is there a provision for pedestrians to be escorted through the work zone by an employee of the contractor (i.e. an off-duty Flagger)?			

	YES	NO	Explanation for "NO" responses
16. Is a road or bridge with an existing sidewalk going to be closed, and the pedestrian detour greater than ½ mile? A shuttle should be provided.			

Project Name:			
Designer:			
BICYCLISTS			
	YES	NO	Explanation for "NO" responses
General			
1. Is an existing signed bike route, bike lane or shared use path being impacted by construction? If YES – If the construction speed limit is > 30 MPH, provide a delineated shoulder/bike lane through the work zone or use a detour on a lower volume road that does not result in excess out of direction travel. If NO – Bicyclists generally accommodated via the standard work zone TTC plan.			
Signs			
2. Are bicycle specific signs provided as part of the TTC plan? (see Typical Applications B1 – B6 in the VTrans Bicycle and Pedestrian Work Zone Traffic Control Guide)			
3. Will a shared roadway (i.e. no shoulder) replace a signed bike route or a bicycle lane and the speed is ≤35 MPH? Use the "Bicycles on Roadway" sign.			
Barricades			
4. Have barricades been provided at the location of the closure or to separate bicyclists from active work areas or traffic?			
Bicycle Channelizing Devices (BCD)			
5. Have BCD been provided for disrupted bicycle facilities if AADT >5000 or Work Zone speed ≥ 40 MPH?			
Width			
6. Has 4 feet of "Clear Space" been provided for bicyclists?			

	YES	NO	Explanation for "NO" responses
Flaggers			
7. Where a shared roadway is provided through the work zone (i.e. no shoulder), is a note included for flaggers that indicates that bicyclists will be held to the end of the queue of vehicles then released last?			
Detours			
8. Does the overall detour for a project use limited access highways (i.e. no bicyclists allowed)? NO – see guidance above. YES – Provide a separate signed detour for bicyclists			
9. Are bicycle detours signed adequately in both directions using bicycle specific signs and noting all route direction changes (M4-9c sign series)?			
Shared Use Paths			
10. When a shared use path is closed, are bicyclists detoured onto sidewalks not designed for two-way multi-use traffic? This practice is not acceptable or compliant.			
11. Is a temporary shared use path used to bypass the work zone (Typical Application B3)? If so, the temporary path shall be at least 8 feet wide and provide an accessible surface.			
12. Is a road or bridge with an existing bicycle lane or route going to be closed and will the bicycle detour be greater than 2 miles? A shuttle should be provided.			

APPENDIX C – WORK ZONE TRAFFIC CONTROL DETAILS

NOTES

- ① CURB RAMPS SHALL BE 48" MIN. WIDTH WITH A FIRM, STABLE AND SLIP RESISTANT SURFACE.
- ② PROTECTIVE EDGING WITH A 2" MIN. HEIGHT SHALL BE PLACED WHEN A CURB RAMP OR LANDING PLATFORM HAS A VERTICAL DROP OF 6" OR GREATER OR HAS A SIDE APRON SLOPE STEEPER THAN 1:3. PROTECTIVE EDGING SHOULD BE CONSIDERED WHEN CURB RAMPS OR LANDING PLATFORMS HAVE A VERTICAL DROP OF 3" OR MORE.
- ③ DETECTABLE EDGING WITH 6" MIN. HEIGHT AND CONTRASTING COLOR SHALL BE PLACED ON ALL CURB RAMP LANDINGS WHERE THE WALKWAY CHANGES DIRECTION (TURNS).
- ④ CURB RAMPS AND LANDINGS SHALL HAVE A 2% MAX. CROSS SLOPE.
- ⑤ CLEAR SPACE OF 48"X48" MIN. SHALL BE PROVIDED ABOVE AND BELOW THE CURB RAMP.
- ⑥ THE CURB RAMP WALKWAY EDGE SHALL BE MARKED WITH A CONTRASTING COLOR, 2" TO 4" WIDE MARKING. THE MARKING IS OPTIONAL WHERE COLOR CONTRASTING EDGING IS USED.
- ⑦ WATER FLOW IN THE GUTTER SYSTEM SHALL NOT BE IMPEDED.
- ⑧ LATERAL JOINTS OR GAPS BETWEEN SURFACES SHALL BE LESS THAN 1/2" WIDTH.
- ⑨ CHANGES BETWEEN SURFACE HEIGHTS SHALL NOT EXCEED 1/2". LATERAL EDGES SHOULD BE VERTICAL UP TO 1/4" HIGH, AND BEVELED AT 1:2 BETWEEN 1/4" AND 1/2" HEIGHT.
- ⑩ CURB RAMPS MAY BE PRE-FABRICATED OR CONSTRUCTED IN PLACE. CONSTRUCTED IN PLACE RAMPS SHALL BE CONSTRUCTED USING PLYWOOD (WITH APPLIED NON-SLIP SURFACE), COMPACTED AGGREGATE, OR TEMPORARY BITUMINOUS CONCRETE.

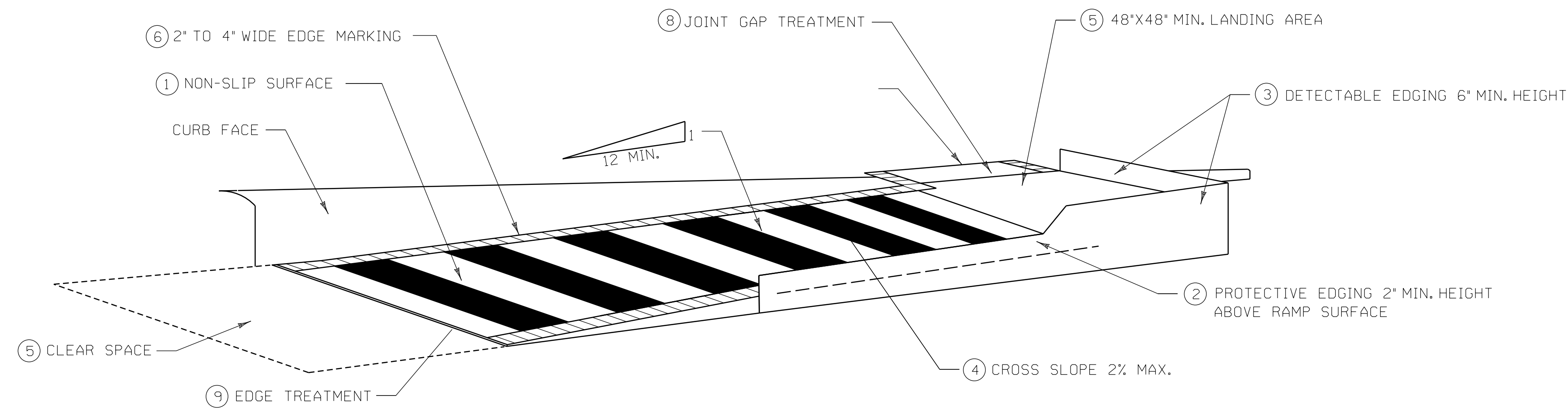

TEMPORARY CURB RAMP
PARALLEL TO CURB

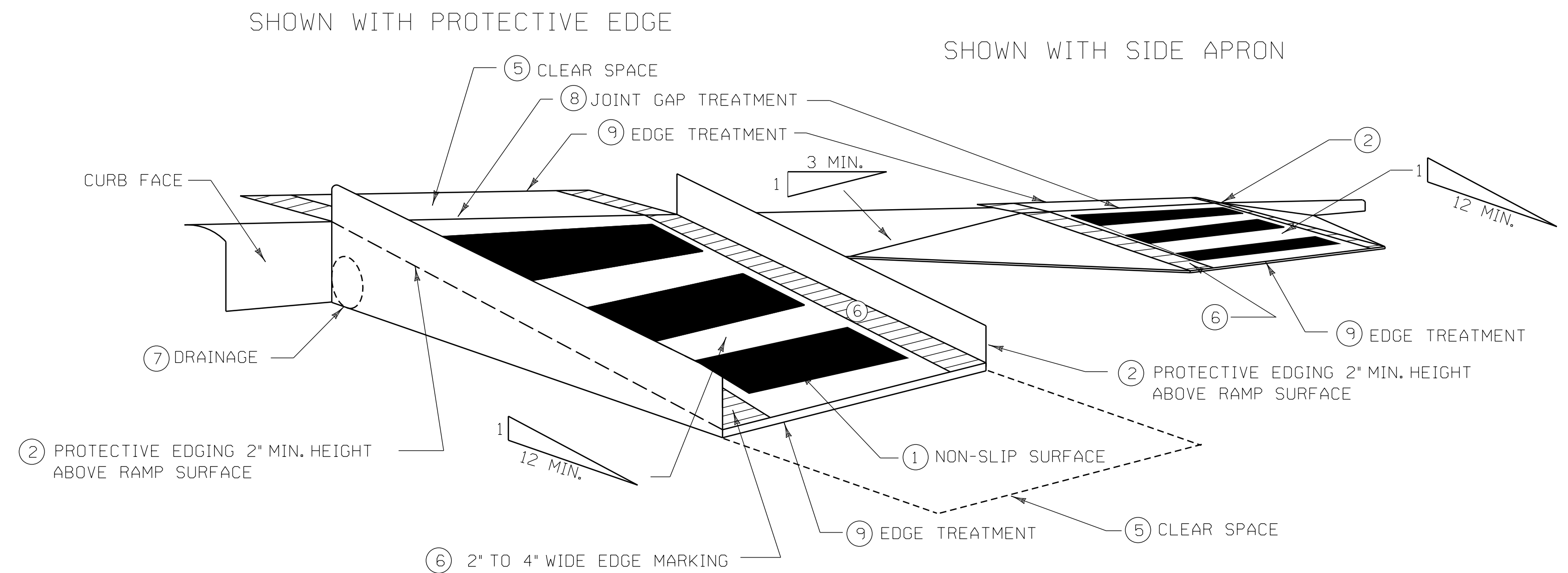

TEMPORARY CURB RAMP
PERPENDICULAR TO CURB

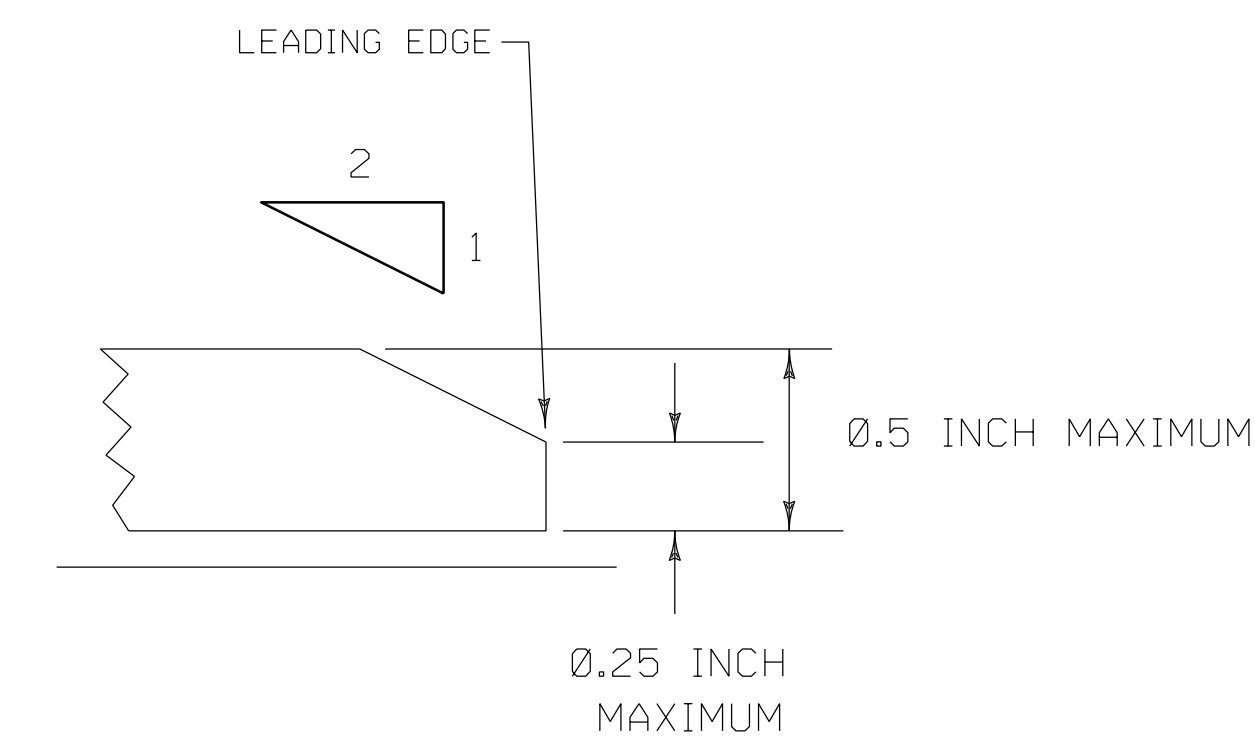

⑨ EDGE TREATMENT

REV.	DATE	DESCRIPTION
0	JUNE 9, 2017	INITIAL DRAFTING (PRE-APPROVED)

TEMPORARY CURB RAMPS

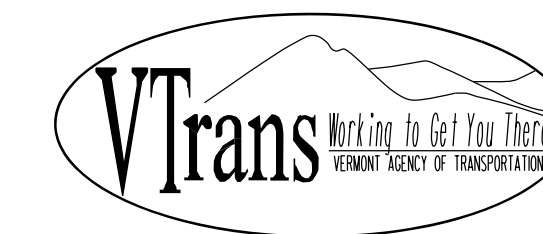

WORK ZONE
TRAFFIC CONTROL
DETAILS

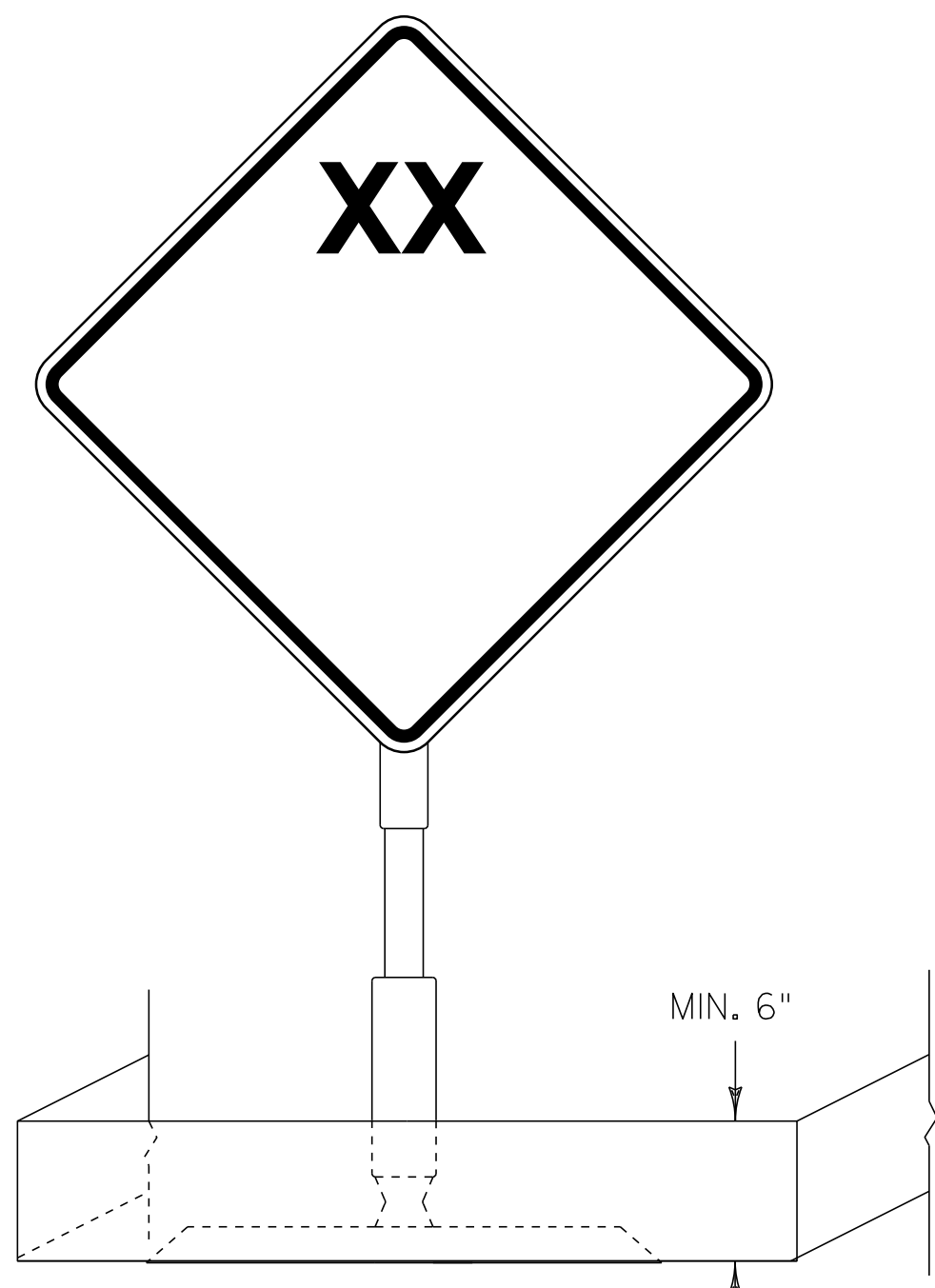

DETECTABLE EDGE FOR PORTABLE SIGN STANDS
NOT TO SCALE

- NOTES:
1. A MAXIMUM OPENING OF 2 INCHES ABOVE WALKWAY SURFACE IS ALLOWED FOR DRAINAGE.
 2. DETECTABLE EDGE SHALL BE CONTINUOUS AND DETECTABLE.
 3. EDGING AROUND PORTABLE SIGN STANDS SHOULD BE USED WHEN SIGN SUPPORTS ARE LOCATED ON A SIDEWALK OR SHARED USE PATH.

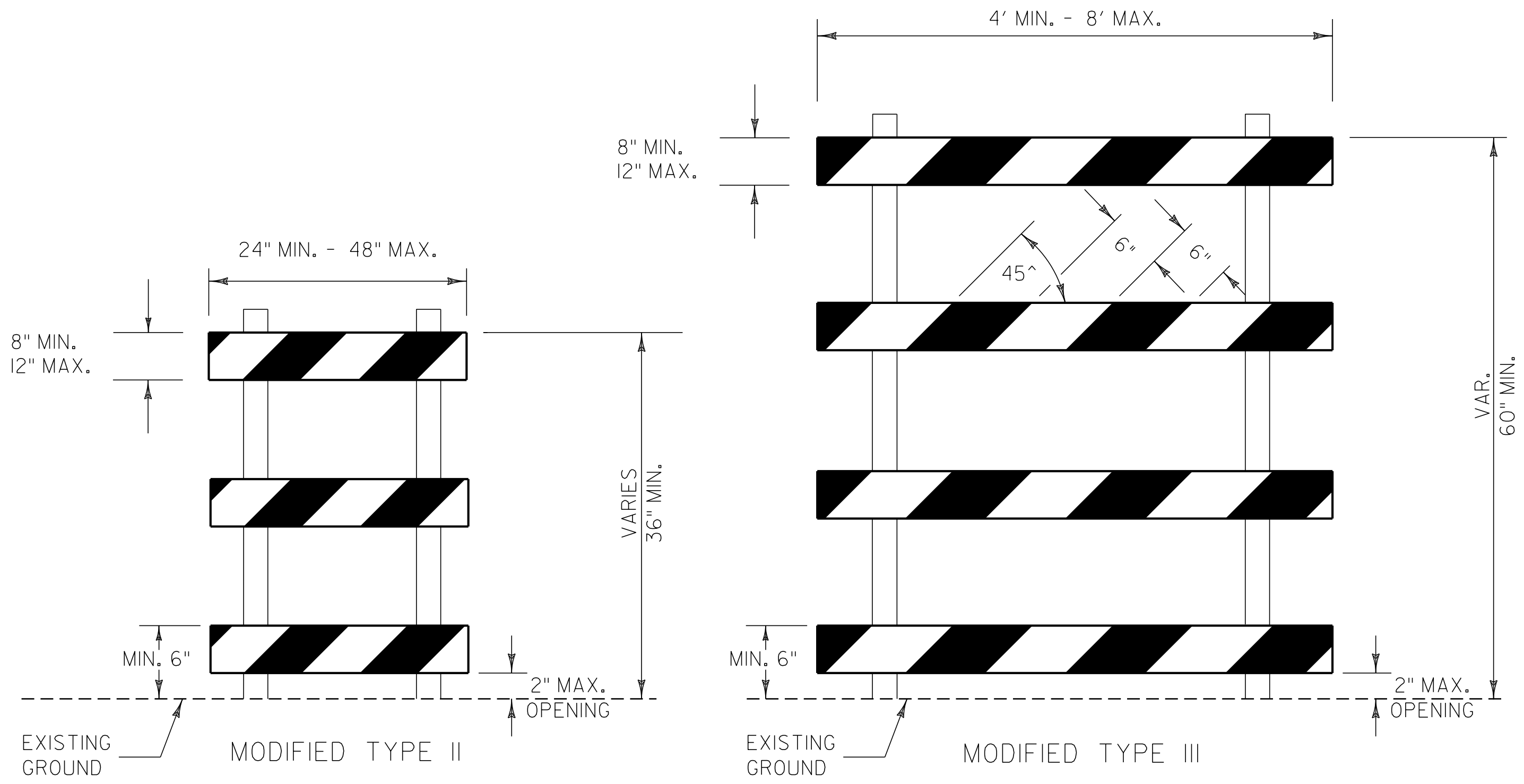

SIDEWALK CLOSURE BARRICADE
NOT TO SCALE

- NOTES:
1. STRIPES ON BARRICADE RAILS SHALL BE ALTERNATING ORANGE AND WHITE RETROREFLECTIVE STRIPES SLOPING DOWNWARD AT AN ANGLE OF 45 DEGREES IN THE DIRECTION ROAD USERS ARE TO PASS.
 2. SANDBAGS MAY BE PLACED ON LOWER FRAME TO PROVIDE REQUIRED BALLAST.
 3. BALLAST SHALL NOT EXTEND ABOVE BOTTOM RAIL OR BE SUSPENDED FROM BARRICADE.
 4. WHEN RAIL LENGTHS ARE LESS THAN 36 INCHES, 4 INCH WIDE STRIPES MAY BE USED.
 5. EACH BARRICADE RAIL SHALL BE 8 TO 12 INCHES WIDE.
 6. DO NOT BLOCK BICYCLE LANES OR SIDEWALKS UNLESS THE FACILITY IS PROPERLY CLOSED AND SIGNED ACCORDING TO THE TRAFFIC CONTROL PLAN.
 7. A "SIDEWALK CLOSED" SIGN (R9-9) SHOULD BE USED AT THE BEGINNING OF A CLOSED SIDEWALK. IT MAY BE A STANDALONE SIGN OR ATTACHED TO THE TOP OF THE BARRICADE.
 8. VERTICAL SPACING OF RAILS IS TO BE EVENLY DIVIDED BETWEEN RAILS.

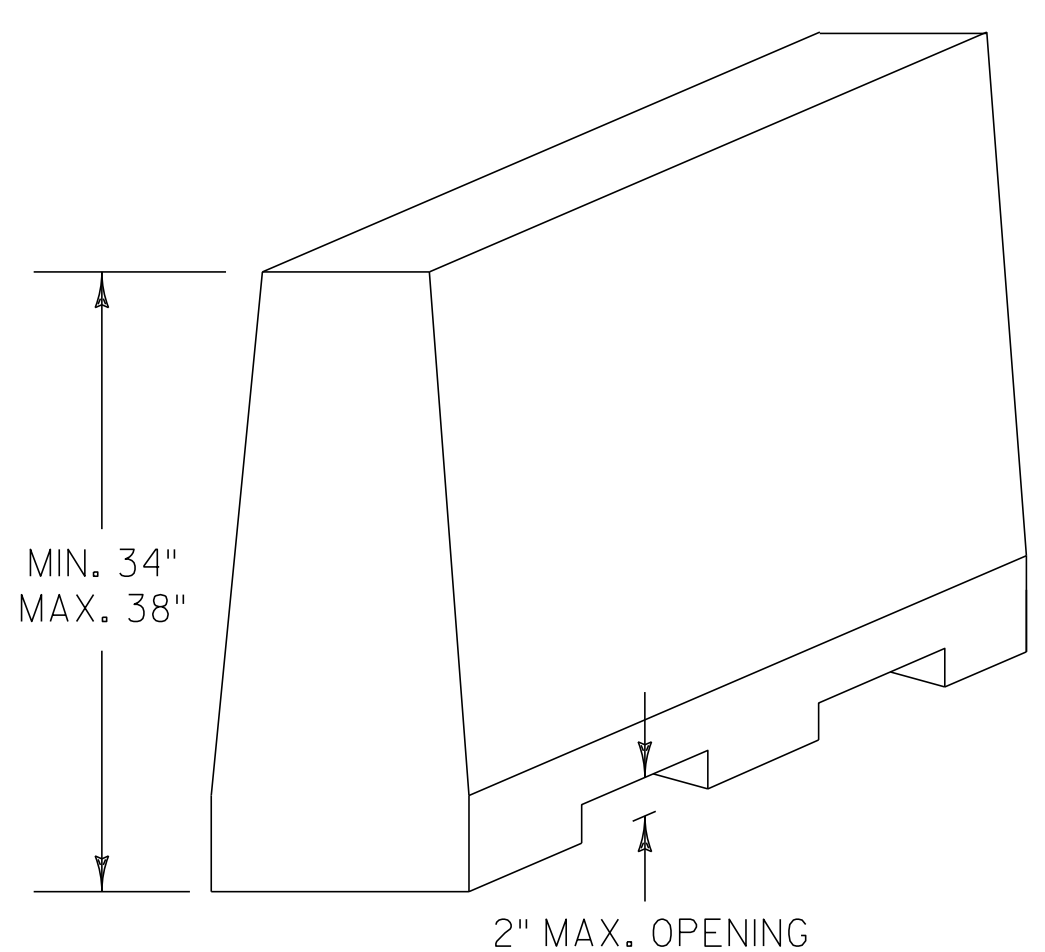

LONGITUDINAL CHANNELIZING DEVICE
NOT TO SCALE

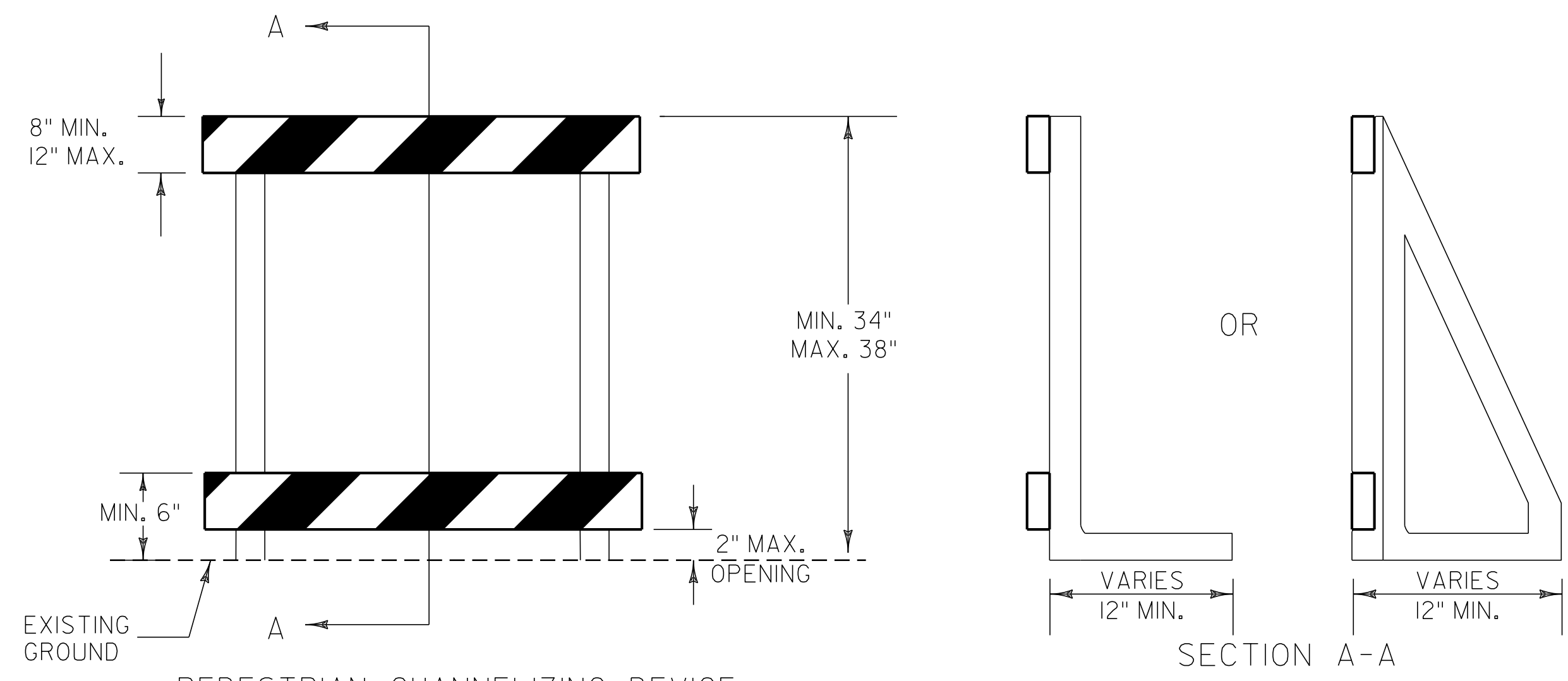

PEDESTRIAN CHANNELIZING DEVICE
NOT TO SCALE

- NOTES:
1. LONGITUDINAL CHANNELIZING DEVICE MAY BE HOLLOW AND FILLED WITH WATER OR SAND AS BALLAST.
 2. DEVICES MAY BE USED AS PEDESTRIAN TRAFFIC CONTROL AND USED INSTEAD OF A LINE OF BARRICADES.
 3. WHEN USED TO FORM A CONTINUOUS PEDESTRIAN CHANNELIZER, CONNECTION POINTS SHOULD BE SMOOTH TO OPTIMIZE LONG CANE AND HAND TRAILING.
 4. THE INTERLOCKING DEVICES SHALL NOT HAVE GAPS THAT ALLOW PEDESTRIANS TO STRAY FROM THE CHANNELIZING PATH.
 5. AN OPENING WITH A 2 INCH MAXIMUM HEIGHT ABOVE THE WALKWAY MAY BE PROVIDED TO ALLOW FOR DRAINAGE.
 6. PEDESTRIAN CHANNELIZING DEVICES MAY BE PRE-FABRICATED OR CONSTRUCTED ON SITE. ALL DEVICES SHALL BE APPROVED BY THE ENGINEER.

- GENERAL NOTES:
1. PEDESTRIAN CHANNELIZING DEVICES MAY BE PAID UNDER ITEM 641.10 TRAFFIC CONTROL OR ITEM 900.645 SPECIAL PROVISION (MAINTENANCE OF PEDESTRIAN TRAFFIC).

REV.	DATE	DESCRIPTION
1	APRIL 4, 2018	DIMENSION AND MISC. NOTE REVISIONS.

PEDESTRIAN TRAFFIC CONTROL DEVICES



WORK ZONE
TRAFFIC CONTROL
DETAILS

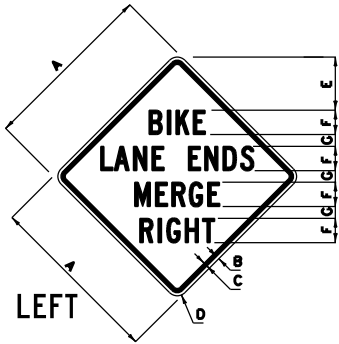

LEFT

A	B	C	D	E	F	G
36	3/8	3/8	2 1/4	10 3/8	5C	2 3/4
48	3/4	1 1/4	3	16 1/8	6C	3

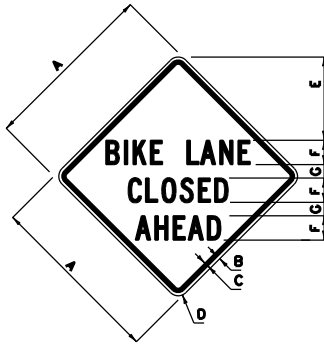

A	B	C	D	E	F	G
36	3/8	3/8	2 1/4	17 3/8	5C	2 3/4
48	3/4	1 1/4	3	23 3/8	6C	3

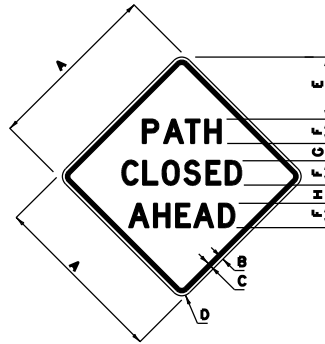

A	B	C	D	E	F	G	H
36	3/8	3/8	2 1/4	12 3/8	50	2 3/4	3 3/4
48	3/4	1 1/4	3	18 3/8	70	3	3

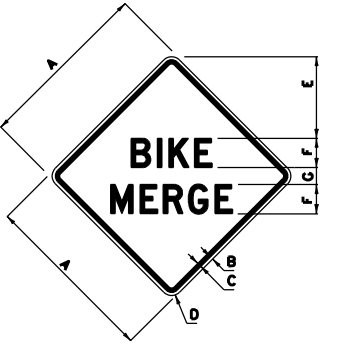

A	B	C	D	E	F	G
36	3/8	3/8	2 1/4	16 3/8	60	3 1/2
48	3/4	1 1/4	3	22 3/8	80	5

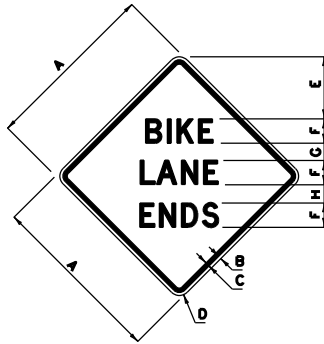

A	B	C	D	E	F	G	H
36	3/8	3/8	2 1/4	12 3/8	50	3 1/2	3 3/4
48	3/4	1 1/4	3	23 3/8	70	4 3/4	5 1/4

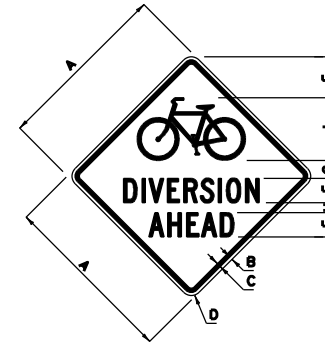

A	B	C	D	E	F	G	H	J
36	3/8	3/8	2 1/4	8 3/8	5C	3 1/4	2	12 3/8
48	3/4	1 1/4	3	14 3/8	6C	5 3/4	6	17 3/8

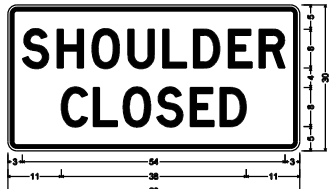

1.88" Radius, 0.75" Border, 0.50" Inset, Black on White; "SHOULDER" D specified length; "CLOSED" D specified length;



1.88" Radius, 0.75" Border, 0.50" Inset, Black on White; "BIKE LANE" D specified length; "CLOSED" D specified length;



1.88" Radius, 0.75" Border, 0.50" Inset, Black on White; "PATH" D; "CLOSED" D specified length;



1.88" Radius, 0.75" Border, 0.50" Inset, Black on Orange; Symbol R0025; "DETOUR" D; Standard Arrow Custom 20.00" X 5.38" 180°;



1.88" Radius, 0.75" Border, 0.50" Inset, Black on Orange; Symbol R0025; "DETOUR" D;



1.88" Radius, 0.75" Border, 0.50" Inset, Black on Orange; Symbol R0025; Standard Arrow Custom 20.00" X 5.38" 180°;



1.88" Radius, 0.75" Border, 0.50" Inset, Black on Orange; Symbol R0025; "DIVERSION" C; Standard Arrow Custom 20.00" X 5.38" 180°;



1.50" Radius, 0.65" Border, 0.38" Inset, Black on Orange; "RETURN TO" C specified length; "SHOULDER" C;

NOTES:

1. ALL DIMENSIONS ARE IN INCHES.
2. ALL SIGNS SHALL CONFORM TO THE CURRENT EDITION OF THE MANUAL ON UNIFORM TRAFFIC CONTROL DEVICES AND ITS LATEST REVISIONS, AND THE VERMONT STANDARD SPECIFICATIONS FOR CONSTRUCTION, DATED AND ITS REVISIONS (ITEM 675- TRAFFIC SIGNS)
3. REFER TO VTRANS STANDARD T-45 FOR SQUARE TUBE SIGN POST AND ANCHOR DETAILS.
4. SIGNS ON THIS SHEET ARE SPECIFIC TO BICYCLE FACILITIES. ADDITIONAL TRAFFIC CONTROL DEVICES MAY BE NEEDED FOR VEHICLES AND PEDESTRIANS IN THE WORK ZONE.

TEXT DESIGN:

LETTERS, DIGITS, ARROWS, SPACING, AND TEXT DIMENSIONS SHALL CONFORM WITH THE "STANDARD ALPHABET FOR HIGHWAY SIGNS AND PAVEMENT MARKINGS" AND DESIGNS PRESCRIBED IN THE STANDARD HIGHWAY SIGNS AS SPECIFIED IN THE MANUAL ON UNIFORM TRAFFIC CONTROL DEVICES (MUTCD).

MATERIALS:

THE SIGN BASE MATERIALS USED FOR TRAFFIC SIGN TYPE A SHALL BE FLAT SHEET ALUMINUM MEETING THE FLAT SHEET ALUMINUM THICKNESS CHART ON STANDARD SHEET T-2.

THE REFLECTIVE MATERIAL SHALL BE AASHTO TYPE III MINIMUM REFLECTIVE SHEETING APPLIED TO THE ENTIRE BACKGROUND OF THE SIGN. THE TEXT OF THE SIGNS SHALL BE LETTERING FILM.

ALL SIGN TEXT SHALL BE IN ACCORDANCE WITH THE RESPECTIVE ALPHABET AS IDENTIFIED IN THE CURRENT "STANDARD HIGHWAY SIGNS AND MARKINGS" (SHSM) BOOK AND ITS LATEST REVISIONS.

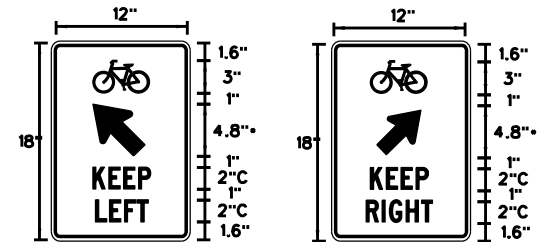

LEGEND - BLACK (NON-REFLECTIVE)
BACKGROUND - WHITE (REFLECTIVE)

• 4" X 6" ARROWS AT 45 DEGREES
BORDER - 0.625"
INSET - 0.375"
RADIUS - 1.5"

NOTE:

THE SIGN SHOWN ABOVE SHOULD BE USED IN THE EVENT THAT BICYCLE AND PEDESTRIAN TRAFFIC ARE DIVERTED SEPARATELY ON A DIVERSION OR DETOUR FROM A SHARED USE PATH.

REV.	DATE	DESCRIPTION
0		ORIGINAL APPROVAL

OTHER STANDARDS REQUIRED: T-1, T-2
VTRANS AND FHWA APPROVAL ON FILE WITH CONTRACT ADMINISTRATION

BICYCLE AND PEDESTRIAN WORK ZONE SIGNS



WORK ZONE TRAFFIC CONTROL DETAILS