

**2010**

SD5-2014.2.19

# VTrans Structures Design Manual

*By the VTrans Structures Section*

**Fifth Edition**



# VTrans Structures Design Manual

**SD5-2014.2.19**

**Fifth Edition**

**LRFD Implementation Committee**



**Structures Section**  
**VTrans Program Development Division**  
1 National Life Drive | Montpelier, VT 05633  
Phone (802) 828-2621 | [www.aot.state.vt.us](http://www.aot.state.vt.us)

SD5-2014.2.19

Copyright © 2010

By Vermont Agency of Transportation (VTrans), Structures Section

Fifth Edition, first printing, 2010

All rights reserved. This guide or any part thereof may not be reproduced in any form without the written permission of the Vermont Agency of Transportation.

Information contain in this work has been obtained from sources believed to be reliable. State of Vermont shall not be responsible for any errors, omissions or damages arising out of this errant information. VTrans has published this work with the following understanding: though the requirements herein must be followed for projects constructed in Vermont, in all cases, Engineering Judgment shall be used and communicated. VTrans is not rendering engineering or other professional services with this guideline. If such services are required, please seek an appropriate professional.

Printed in the U.S.A.

SECTION 1: DESIGN INTRODUCTION.....	1-1
1.1 SCOPE OF THE STRUCTURES LRFD DESIGN MANUAL.....	1-1
1.1.1 Structures Engineering Instructions (SEI).....	1-1
1.2 DESIGN METHODOLOGY FOR HIGHWAY PROJECTS.....	1-2
1.2.1 New Bridges.....	1-2
1.2.2 Rehabilitation Projects.....	1-2
1.2.3 Roadway Design.....	1-2
1.3 PLANS PRODUCTION.....	1-2
1.4 REFERENCES.....	1-3
1.4.1 Roadway Geometrics.....	1-3
1.4.2 Structural.....	1-3
SECTION 2: GENERAL DESIGN AND DETAILS.....	2-1
2.1 LOCATION FEATURES.....	2-1
2.1.1 Route Location.....	2-1
2.1.1.1 General.....	2-1
2.1.1.2 Horizontal Alignment Recommendations.....	2-1
2.1.1.3 Vertical Alignment Recommendations.....	2-1
2.1.1.4 Cross slopes.....	2-1
2.1.1.4.1 General Criteria.....	2-1
2.1.1.4.2 Conditions for Elimination of Superelevation.....	2-2
2.1.1.5 Maximum Grades.....	2-2
2.1.2 Clearances.....	2-2
2.1.2.1 Waterways.....	2-2
2.1.2.2 Vertical Clearance for National Highway System [NHS].....	2-2
2.1.2.3 Railroads Overpass.....	2-2
2.1.2.4 Clear Zones.....	2-3
2.1.3 Bridge Typical Section.....	2-3
2.1.4 Project Limits Definition.....	2-4
2.2 DESIGN OBJECTIVES.....	2-5
2.2.1 Design Criteria Sheet.....	2-5
2.3 BRIDGE LAYOUT PROCEDURES.....	2-6
2.3.1 Working Points.....	2-6
2.3.2 Skew and Askew.....	2-7
2.3.2.1 Skew.....	2-7
2.3.2.2 Askew.....	2-7
2.3.2.3 Bridge Joint Skew Restrictions.....	2-7
2.3.3 Deck on Beam Structures.....	2-8
2.3.4 Concrete Structures.....	2-8
2.3.5 Pipes, Small Boxes and Small Frames.....	2-8
2.4 BRIDGE TYPES.....	2-8
2.4.1 Integral Abutment.....	2-8
2.4.2 Concrete Slab Bridge.....	2-8
2.4.3 Covered Bridge.....	2-9
2.4.4 Steel Truss.....	2-9
2.4.5 Straight Beams and Girders.....	2-9
2.4.6 Curved Beams and Girders.....	2-9
2.4.7 3-Span Continuous Cantilever Bridges.....	2-9
2.5 BRIDGE END DETAIL SCHEMATICS.....	2-9
2.5.1 Location of Expansion Joint.....	2-9

2.5.2 Selection of Bridge End Detail.....	2-9
2.5.2.1 Type A.....	2-10
2.5.2.2 Type B.....	2-10
2.5.2.3 Type C.....	2-10
2.5.2.4 Type D.....	2-10
2.5.2.5 Type E.....	2-10
2.5.2.6 Type F.....	2-10
2.5.2.7 Type G.....	2-10
2.5.2.8 Type H.....	2-10
2.5.2.9 Type I.....	2-10
2.5.3 Bare and Paved Concrete Deck Details.....	2-17
2.5.3.1 Bare Concrete Deck Details.....	2-17
2.5.3.2 Paved Deck Details.....	2-18
2.5.4 Prestressed Concrete Issues.....	2-18
2.6 APPROACH SLABS.....	2-18
2.6.1 When to Use.....	2-18
2.6.2 Approach Slab Details.....	2-18
2.6.3 Approach Slab Properties.....	2-20
2.7 PAVEMENT DESIGN.....	2-20
2.7.1 Roadway Pavement Considerations.....	2-20
2.7.2 Pavement Thickness on Bridge Decks.....	2-20
2.7.3 Pavement Thickness on Approach Slabs.....	2-21
2.7.4 Prestressed Concrete Deck Beams or Slabs.....	2-21
2.7.5 Cold Planing.....	2-21
2.7.6 Sand Borrow Substitution.....	2-21
2.8 GENERAL EARTHWORKS DETAILS.....	2-22
2.8.1 Cofferdam Section.....	2-22
2.8.1.1 Cofferdam Notes.....	2-23
2.8.2 Material behind Abutment.....	2-23
2.8.3 Subbase Details.....	2-23
2.8.3.1 Subbase Detail at Abutment.....	2-23
2.8.3.2 Subbase at Begin and End of Project.....	2-24
2.8.4 Typical Channel Section.....	2-24
2.9 Snow Fence.....	2-24
SECTION 3: LOADS AND LOAD FACTORS.....	3-1
3.1 GENERAL DESIGN.....	3-1
3.2 LOAD FACTORS AND COMBINATIONS.....	3-1
3.2.1 Covered Bridges.....	3-2
3.2.1.1 Load Combinations for Buildings, Including Covered Bridges.....	3-2
3.2.2 Load Modifiers.....	3-3
3.3 PERMANENT LOADS.....	3-3
3.3.1 Dead Loads (DL, DW and EV).....	3-3
3.3.2 Design Pavement Thickness.....	3-3
3.3.3 Bridge Rail.....	3-3
3.3.4 Earth Loads (EH, ES, LS and DD).....	3-4
3.4 LIVE LOAD.....	3-4
3.4.1 Applying Live Load (LL).....	3-4
3.4.2 Live Load on Buried or Earth Retaining Structures.....	3-4
3.4.3 Pedestrian Live Load.....	3-5
3.4.4 Centrifugal Force (CE).....	3-5
3.4.5 Breaking Force (BR).....	3-5

3.4.6 Snow Removal Live Load .....	3-5
3.5 WATER LOADS (WA).....	3-6
3.5.1 Stream Flow Pressure.....	3-6
3.6 WIND LOAD (WL AND WS).....	3-6
3.6.1 Wind Load on Conventional Bridges.....	3-6
3.6.2 Wind Load on Live Load .....	3-6
3.6.3 Wind Load on Buildings Including Covered Bridges .....	3-7
3.6.3.1 Wind Speed Conversion .....	3-7
3.6.3.2 Importance Factor for Wind Loads .....	3-8
3.6.3.3 Minimum Wind Load on Covered Bridges .....	3-9
3.6.3.4 Anchorage .....	3-9
3.6.3.5 Covered Bridge Types.....	3-9
3.6.3.5.1 Open Covered Bridge .....	3-9
3.6.3.5.2 Partially Enclosed Covered Bridge.....	3-9
3.6.3.5.3 Enclosed Covered Bridge .....	3-10
3.6.3.6 Determining Wind Load for Covered Bridges .....	3-10
3.6.3.6.1 Main Wind Force Resisting System (MWFRS) .....	3-10
3.6.3.6.2 Components and Cladding.....	3-14
3.6.3.6.3 Area to Load for Cladding and Components .....	3-15
3.6.4 Wind Load on Signs.....	3-15
3.6.4.1 Reserved Capacity.....	3-15
3.6.4.2 Fatigue Design Checks.....	3-15
3.7 ICE LOAD (IC).....	3-18
3.7.1 Ice Pressure .....	3-18
3.7.2 Snow Loads.....	3-18
3.7.2.1 Snow Load on Bridge Decks .....	3-18
3.7.2.2 Snow Load on Buildings including Covered Bridges .....	3-19
3.7.2.2.1 Snow Loads on Covered Bridges .....	3-20
3.7.2.2.2 Unbalanced Roof Snow Load.....	3-21
3.7.2.3 Ice Load on Signs .....	3-23
3.8 EARTHQUAKE EFFECTS (EQ).....	3-23
3.8.1 Seismic Design Specifications .....	3-23
3.8.2 Design Criteria .....	3-24
3.8.3 Seismic Design for Covered Bridges .....	3-24
3.8.3.1 Bridge Decks of Covered Bridges .....	3-24
3.8.3.2 Site Class Definition.....	3-24
3.8.3.3 Adjustment to Mapped Spectral Response Acceleration Based on Site Class .....	3-27
3.8.3.4 Design Spectral Response Acceleration Parameters .....	3-28
3.8.3.5 Use Category .....	3-28
3.8.3.6 Seismic Design Category .....	3-28
3.8.3.6.1 Seismic Design Category Based on Ss Only .....	3-28
3.8.3.6.2 Fundamental Period.....	3-28
3.8.4 Design Requirements for Seismic Design Category A.....	3-29
3.8.5 Simplified Analysis Procedure for Seismic Design of Covered Bridges Meeting Seismic Design Categories B and C.....	3-29
3.8.5.1 Seismic Base Shear .....	3-30
3.8.5.2 Vertical Distribution.....	3-30
3.8.5.3 Horizontal Shear Distribution.....	3-30
3.8.5.4 Anchorage of Covered Bridge.....	3-30
3.8.5.5 Seismic Load Effects and Combinations .....	3-30
3.8.5.6 Overturning .....	3-31
3.8.5.7 Structural Drift .....	3-31
3.8.6 Design Requirements for Seismic Design Category D.....	3-31
3.9 EARTH PRESSURE (EH, ES, LS AND DD).....	3-31



3.10 FORCE EFFECTS DUE TO SUPERIMPOSED DEFORMATIONS (TU, TG, SH, CR AND SE).....	3-32
3.10.1 Thermal Forces.....	3-32
3.11 FRICTION FORCES.....	3-32
3.12 CONSTRUCTION LOADS.....	3-34
3.12.1 Formwork.....	3-34
3.12.2 Structural Elements.....	3-34
3.12.3 Construction Live Load.....	3-34
3.12.3.1 Temporary Live Loads.....	3-34
SECTION 4: STRUCTURAL ANALYSIS AND EVALUATION.....	4-1
4.1 GENERAL INFORMATION.....	4-1
4.2 SOFTWARE.....	4-1
4.2.1 3D/2D Finite Element Modeling.....	4-1
4.2.2 General Design.....	4-1
4.2.3 Prestress Concrete Design.....	4-2
4.2.4 Steel Beam Design.....	4-2
4.2.5 Pile Design and Analysis.....	4-2
4.3 LOAD DISTRIBUTION.....	4-2
4.3.1 Dead Load Distribution.....	4-2
4.3.1.1 Bridge Decks with Curved Beams.....	4-2
4.3.1.2 Non-compliant Bridge Decks.....	4-2
4.3.1.3 Deck, Wearing Course, Future Wearing Surface, Railing, Barriers, and Medians.....	4-2
4.3.1.4 Miscellaneous Loads - Conduits, Sign Structure, etc.....	4-3
4.3.2 Live Load Distribution.....	4-3
4.3.2.1 Steel and Prestressed Concrete Beams.....	4-3
4.3.2.2 Slab Spans and Timber Decks.....	4-3
4.3.3 Pedestrian Bridge Live Load.....	4-3
4.4 SUBSTRUCTURE FIXITY.....	4-3
4.5 STRUCTURAL MODELS.....	4-4
4.6 RAILROAD BRIDGES & BRIDGES OR STRUCTURES NEAR RAILROADS.....	4-4
SECTION 5: CONCRETE STRUCTURES.....	5-1
5.1 MATERIAL PROPERTIES.....	5-1
5.1.1 Concrete Types.....	5-1
5.1.1.1 High Performance Concrete.....	5-1
5.1.1.1.1 HP Class AA.....	5-1
5.1.1.1.2 HP Class A.....	5-1
5.1.1.1.3 HP Class B.....	5-1
5.1.1.1.4 HP Class SCC.....	5-1
5.1.1.1.5 HP Class LW <sup>1</sup> .....	5-1
5.1.1.2 Precast Concrete.....	5-1
5.1.1.3 Prestressed Concrete.....	5-2
5.1.1.4 Structural Concrete.....	5-2
5.1.1.5 Uses for Concrete Classes.....	5-2
5.1.1.6 Release Strength.....	5-2
5.1.1.7 Coefficient of Thermal Expansion.....	5-3
5.1.2 Reinforcing.....	5-3
5.1.2.1 Sizes of Reinforcing Steel.....	5-3
5.1.2.2 Types of Reinforcing Steel.....	5-4
5.1.2.3 Prestressing Steel Strands.....	5-5
5.1.2.4 Transverse Post-Tensioning Tendons.....	5-5

5.1.2.5 Mechanical or Welded Reinforcing Splices .....	5-5
5.1.2.6 Minimum Concrete Cover .....	5-6
5.1.3 Concrete Anchors .....	5-6
5.2 CAST-IN-PLACE CONCRETE DETAILS .....	5-7
5.2.1 Minimum Concrete Thickness .....	5-7
5.2.1.1 Concrete Deck Slabs on Longitudinal Components (Beams) .....	5-7
5.2.1.1.1 Minimum Deck Thickness .....	5-7
5.2.1.2 Walls .....	5-7
5.2.1.3 Footings .....	5-7
5.2.1.3.1 Minimum Footing Thickness .....	5-7
5.2.2 Joints in Concrete .....	5-7
5.2.2.1 Horizontal Construction Joints in Abutments, Piers & Walls .....	5-7
5.2.2.2 Expansion Joints in Abutments, Piers & Walls .....	5-8
5.2.2.3 Contraction Joints in Abutments, Piers & Walls .....	5-8
5.2.2.4 Design Software (Conspan) .....	5-8
5.2.3 Continuity .....	5-8
5.2.4 Shrinkage and Temperature Reinforcement .....	5-8
5.2.5 Detailing Reinforcing .....	5-9
5.2.5.1 Varying Reinforcement Bar Lengths .....	5-9
5.2.5.2 Reinforcing for Wing wall Corners .....	5-9
5.3 PRESTRESS CONCRETE DETAILS .....	5-10
5.3.1 Skews .....	5-10
5.3.2 Surface Treatment .....	5-10
5.3.3 Preferred Concrete Sections .....	5-10
5.3.3.1 Site Classifications for Butted Beams .....	5-11
5.3.3.2 Structural Overlays .....	5-11
5.3.4 Shear Keys .....	5-11
5.3.5 Grout .....	5-12
5.3.6 Transverse Tendons .....	5-12
5.3.6.1 Strands per Sleeve .....	5-13
5.3.6.2 Tendon Pull Requirements .....	5-14
5.3.6.3 Tendon Anchorage Devices .....	5-14
5.3.6.4 Grout Placement Control .....	5-14
5.3.7 Butted Deck Beam Framing Plan .....	5-14
5.3.8 End Reinforcing Details .....	5-15
5.3.9 Void Drains .....	5-16
5.3.10 Strand Patterns .....	5-16
5.4 CONCRETE BRIDGE END DETAILS .....	5-16
5.4.1 Anchor Bolt Detail .....	5-17
5.4.2 Waterstop .....	5-18
5.4.3 Negative Moment Reinforcement .....	5-19
5.5 DEVELOPMENT AND SPLICES OF REINFORCEMENT .....	5-19
5.5.1 Development of Reinforcement .....	5-19
5.5.2 Splices of Bar Reinforcement .....	5-19
5.5.3 Commonly Used Splices Lengths .....	5-19
5.5.4 Splice modifiers .....	5-20
5.5.5 Common Splices .....	5-21
5.5.5.1 Category 1 .....	5-21
5.5.5.2 Category 2 .....	5-21
5.5.5.3 Category 3 .....	5-22
5.6 CONSTRUCTION .....	5-23
5.6.1 Deck Concrete Placement Sequence .....	5-23
5.6.1.1 Simple Spans .....	5-23
5.6.1.2 Continuous Spans .....	5-23
5.6.1.3 Three Span Continuous Cantilevers .....	5-23

5.6.1.4 Deck Construction Joint Details .....	5-23
5.6.1.5 Curbs and Sidewalks .....	5-24
5.6.1.6 Deck Finish .....	5-24
5.6.2 Sequence of Construction for Prestressed Voided Slabs and Box Beams.....	5-24
5.6.2.1 Layout Working Lines.....	5-24
5.6.2.2 Verify Beam Seat Elevations.....	5-24
5.6.2.3 Erect Beams.....	5-24
5.6.2.4 Install Oakum or Equivalent Joint Filler (backer rod).....	5-24
5.6.2.5 Install Transverse Post-tensioning Tendons .....	5-24
5.6.2.6 Grout Shear Keys .....	5-25
5.6.2.7 Post-Tension Transverse Tendons.....	5-25
5.6.2.8 End Details .....	5-25
5.6.2.9 Finish Work.....	5-25
5.6.2.10 Construction Joints.....	5-25
5.7 CONCRETE BRIDGE END DETAILS.....	5-26
5.7.1 Concrete Bridge End Details - Type A.....	5-26
5.7.2 Concrete Bridge End Details - Type B.....	5-27
5.7.3 Concrete Bridge End Details - Type C.....	5-29
5.7.4 Concrete Bridge End Details - Type D.....	5-30
5.7.5 Concrete Bridge End Details - Type E.....	5-31
5.7.6 Concrete Bridge End Details - Type F.....	5-31
5.7.7 Concrete Bridge End Details - Type G.....	5-32
5.7.8 Concrete Bridge End Details - Type H.....	5-32
5.7.9 Concrete Bridge End Details - Type I.....	5-33
SECTION 6: STEEL STRUCTURES.....	6-1
6.1 GENERAL DESIGN.....	6-1
6.2 MATERIALS .....	6-1
6.2.1 Structural Steel.....	6-1
6.2.1.1 Weathering Steel .....	6-1
6.2.1.2 High Performance Steel (HPS).....	6-1
6.2.2 Bolts .....	6-2
6.2.3 Stud Shear Connectors .....	6-2
6.2.4 Weld Metal.....	6-2
6.2.5 Paint .....	6-2
6.2.5.1 Standard Paint Colors.....	6-2
6.2.5.1.1 Weathering Steel .....	6-2
6.2.5.1.2 Painted Steel.....	6-2
6.2.5.1.3 Bridge Rail.....	6-2
6.3 GENERAL DIMENSION AND DETAIL REQUIREMENTS.....	6-3
6.3.1 Dead Load Camber.....	6-3
6.3.1.1 Dead Load Camber at Midspan.....	6-3
6.3.1.2 Camber Tolerance .....	6-4
6.3.2 Steel Plate Thickness.....	6-4
6.3.2.1 Minimum Thickness.....	6-4
6.3.2.2 Maximum Thickness .....	6-4
6.3.2.3 Minimizing Number of Plate Thicknesses .....	6-4
6.3.2.4 Recommended Plate Thicknesses.....	6-4
6.3.3 Diaphragms and Cross Frames.....	6-5
6.3.3.1 Connection Plates for Diaphragms.....	6-5
6.3.3.2 Bearing Diaphragms & Cross Frames .....	6-5
6.3.3.3 Intermediate Diaphragms & Cross Frames.....	6-5
6.3.3.4 Pier Diaphragms & Cross Frames .....	6-5
6.3.3.5 Curved Superstructures .....	6-5
6.3.4 Lateral Bracing.....	6-6
6.3.5 Paint .....	6-6

6.3.5.1 Painted Joints.....	6-6
6.3.5.2 Lead Paint.....	6-6
6.3.6 Girder Flange Proportions.....	6-6
6.3.7 Shear Connectors.....	6-6
6.3.8 Stiffeners.....	6-6
6.3.8.1 Transverse Intermediate Stiffeners.....	6-6
6.3.8.2 Bearing Stiffeners.....	6-6
6.3.9 Cover Plates.....	6-7
6.4 CONNECTIONS AND SPLICES.....	6-7
6.4.1 General.....	6-7
6.4.2 Bolted Connections.....	6-7
6.4.2.1 Slip Critical Design.....	6-7
6.4.2.1.1 Slip Coefficients.....	6-7
6.4.2.2 Bolt Detailing.....	6-7
6.4.3 Welded Connections.....	6-7
6.4.3.1 Weld sizes.....	6-9
6.4.4 Splices.....	6-9
6.4.4.1 Maximum Beam Shipping Length.....	6-9
6.4.4.2 Span Length Requirements.....	6-9
6.4.4.3 Splice Locations.....	6-9
6.4.4.4 Axial Capacity.....	6-10
6.4.4.5 Moment Capacity.....	6-10
6.4.4.5.1 Web Splice.....	6-10
6.4.4.5.2 Flange Splice.....	6-10
6.4.4.6 Shear Capacity.....	6-10
6.4.4.6.1 Plate Girder.....	6-10
6.4.4.6.2 Rolled Beam.....	6-10
6.4.4.7 Bolted Splices.....	6-10
6.4.4.7.1 Non-Composite Areas.....	6-10
6.4.4.8 Welded Splices.....	6-11
6.4.5 Gusset Plates in Steel Truss Bridges.....	6-12
6.4.5.1 Resistance in Gusset Plates.....	6-13
6.5 FATIGUE AND FRACTURE CONSIDERATIONS.....	6-14
6.5.1 Fatigue.....	6-14
6.5.2 Redundancy - Fracture Critical Members.....	6-14
6.5.2.1 Redundancy.....	6-14
6.5.2.2 Primary and Secondary Members.....	6-14
6.5.3 Fracture Critical Members.....	6-14
6.5.3.1 Defining on Plans.....	6-15
6.5.3.1.1 Fracture Critical Members.....	6-15
6.5.3.1.2 Charpy V-Notch Test.....	6-15
6.6 DESIGN PROCEDURES FOR STEEL BRIDGES.....	6-16
6.6.1 Straight Beams.....	6-16
6.6.1.1 Refined Methods of Analysis.....	6-16
6.6.2 Curved Beams.....	6-16
6.6.2.1 Refined Methods of Analysis.....	6-16
6.6.2.2 Expansion Bearing Orientation.....	6-16
6.6.3 3-Span Continuous Cantilever Bridges.....	6-16
6.6.4 Construction.....	6-16
SECTION 7: ALUMINUM STRUCTURES.....	7-1
7.1 GENERAL DESIGN.....	7-1
SECTION 8: WOOD STRUCTURES.....	8-1
8.1 GENERAL DESIGN.....	8-1

8.1.1 Design Methodology .....	8-1
8.1.2 Live and Dead Loads .....	8-1
8.2 MATERIALS .....	8-1
8.2.1 Base Resistance and Modulus of Elasticity .....	8-1
8.2.2 Preservative Treatment .....	8-1
8.2.2.1 Requirement for Treatment .....	8-1
8.2.2.2 Wearing Surface .....	8-1
8.2.2.3 Timber Deck on Steel Supports .....	8-1
SECTION 9: DECK AND DECK SYSTEMS .....	9-1
9.1 GENERAL DESIGN .....	9-1
9.2 GENERAL DECK DETAILS .....	9-1
9.2.1 Bridge Rail .....	9-1
9.2.2 Curbs .....	9-1
9.2.2.1 Curbs on Prestress Deck Beam Bridge Decks .....	9-1
9.2.3 Deck Drainage .....	9-1
9.2.3.1 Scuppers .....	9-1
9.2.3.2 Downspouts .....	9-1
SECTION 10: FOUNDATIONS .....	10-1
10.1 ROCK AND SOIL PROPERTIES .....	10-1
10.2 LIMIT STATES AND RESISTANCE FACTORS .....	10-1
10.2.1 Definitions of Flood Events .....	10-1
10.2.2 Design Scenarios .....	10-1
10.2.2.1 Service Limit State .....	10-1
10.2.2.2 Strength Limit State .....	10-1
10.2.2.3 Extreme Event Limit State .....	10-1
10.2.3 Spread Footings .....	10-1
10.2.3.1 Bearing Resistance .....	10-1
10.2.3.2 Spread Footing on Soil .....	10-2
10.2.3.2.1 Abutments .....	10-2
10.2.3.2.2 Piers .....	10-2
10.2.3.3 Spread Footing on Bedrock .....	10-2
10.2.4 Driven Piles .....	10-2
10.2.4.1 Pile Bearing Values .....	10-3
10.2.4.1.1 Vertical Design Loading .....	10-3
10.2.4.1.2 Horizontal Design Loading .....	10-3
10.2.4.2 Friction Piles .....	10-3
10.2.4.3 Pile Spacing and Clearances .....	10-3
10.2.5 Drilled Shafts .....	10-4
SECTION 11: ABUTMENTS, PIERS AND WALLS .....	11-1
11.1 GENERAL DESIGN .....	11-1
11.1.1 Design Methodology .....	11-1
11.1.2 Design Economy .....	11-1
11.2 SUBSTRUCTURES AND RETAINING WALLS .....	11-1
11.2.1 Earth Pressure .....	11-1
11.2.2 Weep Holes .....	11-1
11.3 FOOTING DESIGN .....	11-2
11.3.1 General Design .....	11-2
11.3.2 Toe Design .....	11-3
11.3.2.1 Toe Steel .....	11-3

11.3.3 Heel Design ..... 11-3

11.4 COMPRESSION MEMBERS WITH OR WITHOUT FLEXURE ..... 11-3

SECTION 12: BURIED STRUCTURES ..... 12-1

12.1 GENERAL DESIGN ..... 12-1

    12.1.1 Weep Holes ..... 12-1

12.2 CULVERT DESIGN ..... 12-1

    12.2.1 Minimum Cover ..... 12-1

    12.2.2 Coatings ..... 12-1

12.3 BURIED STRUCTURES AND TUNNEL LINERS ..... 12-1

    12.3.1 General Design Features ..... 12-1

    12.3.2 Loading ..... 12-1

    12.3.3 Safety Against Soil Failure..... 12-1

    12.3.4 Scour ..... 12-1

    12.3.5 Soil Envelope ..... 12-1

12.4 METAL PIPE, PIPE ARCH, AND ARCH STRUCTURES ..... 12-2

    12.4.1 General ..... 12-2

12.5 LONG-SPAN STRUCTURAL PLATE STRUCTURES ..... 12-2

    12.5.1 General ..... 12-2

    12.5.2 Safety Against Structural Failure ..... 12-2

        12.5.2.1 Acceptable Special Features ..... 12-2

            12.5.2.1.1 Continuous Longitudinal Stiffeners ..... 12-2

            12.5.2.1.2 Reinforcing Ribs ..... 12-2

    12.5.3 Settlement Limits ..... 12-2

    12.5.4 End Treatment ..... 12-2

        12.5.4.1 Cut Ends ..... 12-2

    12.5.5 Headwalls ..... 12-2

12.6 STEEL TUNNEL LINER PLATE ..... 12-2

12.7 EARTHWORKS CONSIDERATIONS ..... 12-3

    12.7.1 Undercuts ..... 12-3

    12.7.2 Backfill Materials ..... 12-3

    12.7.3 Horizontal Excavation and Backfill Limits ..... 12-3

SECTION 13: RAILINGS GENERAL DESIGN ..... 13-1

13.1 GENERAL DESIGN ..... 13-1

13.2 BRIDGE RAIL GUIDANCE ..... 13-1

    13.2.1 Definitions ..... 13-2

        13.2.1.1 Procedure for selecting Test Level ..... 13-2

        13.2.1.2 Bridge and Approach Rail Selection ..... 13-2

13.3 CONSIDERATIONS FOR PEDESTRIANS ..... 13-2

    13.3.1 Design Speed of 45 mph or Less: ..... 13-2

    13.3.2 Design Speed of 50 mph or Higher: ..... 13-2

13.4 Average Daily Traffic Adjustment Factors ..... 13-3

13.5 Test Level Selection Table ..... 13-5

13.6 Approved Bridge and Approach Rail Options ..... 13-7

SECTION 14: JOINTS AND BEARING ..... 14-1

14.1 GENERAL DESIGN .....	14-1
14.2 JOINTS .....	14-1
14.2.1 Joint Types .....	14-1
14.2.1.1 Modular Expansion Joint.....	14-1
14.2.1.2 Vermont Joint.....	14-1
14.2.1.2.1 Square Plate Vermont Joint .....	14-1
14.2.1.2.2 Finger Plate Vermont Joint.....	14-2
14.2.1.3 Asphaltic Plug Joint.....	14-2
14.2.1.4 Pavement Saw Cut Joint.....	14-2
14.2.1.4.1 Saw Cut Joint Note .....	14-2
14.3 BEARINGS .....	14-3
14.3.1 Requirements for Bearings.....	14-3
14.3.1.1 Horizontal Force and Movement.....	14-3
14.3.1.1.1 Coefficients of Friction.....	14-3
14.3.1.1.2 Curtain Walls.....	14-3
14.3.2 Prestressed Deck Beam Bearing Layout .....	14-4
14.4 LOAD PLATES AND ANCHORAGE FOR BEARINGS.....	14-4
14.4.1 Plates for Load Distribution .....	14-4
14.4.1.1 Material .....	14-4
14.4.1.2 Holes.....	14-5
14.4.1.3 Sole Plates .....	14-5
14.4.2 Tapered Plates .....	14-5
14.4.3 Anchorage and Anchor Bolts .....	14-5
14.5 SPECIAL DESIGN PROVISIONS FOR BEARINGS.....	14-5
14.5.1 Metal Rocker and Roller Bearings .....	14-5
14.5.2 Steel-Reinforced Elastomeric Bearings – Method A.....	14-5
14.5.3 Pot Bearings .....	14-5
14.6 CORROSION PROTECTION.....	14-6
14.7 DETAILING BEARINGS .....	14-6
14.8 PAYMENT FOR BEARINGS .....	14-6
SECTION 15: LOAD RATING .....	15-1
15.1 GENERAL.....	15-1
15.2 LOAD RATING METHODOLOGY FOR HIGHWAY PROJECTS/ EXISTING BRIDGES.....	15-1
15.2.1 Vehicular Live Loads .....	15-3
15.2.1.1 Rating in Tons .....	15-3
15.3 WORKING STRESS AND LOAD FACTOR DESIGNS.....	15-3
15.4 LOAD AND RESISTANCE FACTOR RATING.....	15-3
15.4.1 Load Rating Buried Structures .....	15-3
15.5 LOAD RATING PROCEDURES .....	15-3
APPENDIX A: REPORT AN ERROR OR MAKE A SUGGESTION .....	A-1
APPENDIX B: NOTES.....	B-1

## SECTION 1: DESIGN INTRODUCTION

### 1.1 SCOPE OF THE STRUCTURES LRFD DESIGN MANUAL

The content of the Structures Manual supersedes the AASHTO LRFD Bridge Design Specifications. The intent of this division is to address the specific needs of Vermont highway structures.

The Structures Section has based the content of this manual on the LRFD design philosophy as published by AASHTO.

#### 1.1.1 Structures Engineering Instructions (SEI)<sup>1</sup>

Structures Engineering Instructions (SEI) are intended to be utilized for the expeditious dissemination of important information and will normally be used to issue specialized engineering-related directions for designs and projects advanced through or by the Structures Section. They will generally relate to the following:

- The timely issuance of new or revised specifications, direction, guidance, or procedure for design of highway structures and Structure Section Projects until such time that the material is incorporated into the Structures Manual, Standard Specifications or other document.
- To announce the issuance of new or revised detail sheets, standard drawings, and CADD cells
- To announce the latest revision of design software and in-house developed spreadsheets or MathCAD worksheets
- To forward technical advisories or requirements from other VTrans Sections or Divisions, FHWA or AASHTO

The Structures Section intends the SEI process to supplement VTrans Policy and PDD Procedure. In the case of a conflict between information contained in a SEI and VTrans Policy or PDD Procedure, the VTrans Policy or PDD Procedure shall govern.

The approving authority for a SEI is the Structures Program Manager.

A SEI remains "in-force" or "active" until the Structures Section incorporates the body of the SEI in a new Specification, a Structures Manual revision or other official document. The Structures Section may reissue or amend a SEI into a new SEI, which will subsequently update and replace the existing. A SEI may be retired (superseded) as deemed necessary by the Structures Program Manager.

Through their Project Manager or Supervisor, anyone in the Structures Section may recommend a subject for issuance as a SEI to the Structures Program Manager. When bringing such matters forward, the staff member shall include the following:

- A summary of the proposed SEI covering the issue or matter
- Proposed wording for the SEI, including content with any interpretations and proposed direction

Whenever practical, Project Managers will receive circulated draft SEIs for their comments prior to the Structures Section issuing a final draft.

Approved SEIs will be distributed electronically and available on the VTrans internet as soon as possible.

---

<sup>1</sup> Policy as stated in Structures Engineering Instructions 07-001 (10/30/07)



## **1.2 DESIGN METHODOLOGY FOR HIGHWAY PROJECTS**

### **1.2.1 New Bridges**

Design new vehicle and pedestrian bridges, earth-retaining structures, and buried structures that have not progressed beyond the Preliminary Plan Stage as of October 1, 2007 using the AASHTO Load and Resistance Factor Design (LRFD) specifications.<sup>2</sup>

### **1.2.2 Rehabilitation Projects**

Design work relating to the maintenance or rehabilitation of existing bridges, earth-retaining structures, and buried structures shall be done in accordance with AASHTO LRFD.

Design work relating to the maintenance or rehabilitation of existing bridges, earth-retaining structures, and buried structures not located on the NHS, and historic trusses and historic arches regardless of location may be exempted from this requirement.

Design work related to the maintenance or rehabilitation projects based on the AASHTO Standard Specifications shall use the Allowable Stress Design (ASD) methodology.

### **1.2.3 Roadway Design**

Consult the VTrans Roadway Design Manual for specific design requirements of roadway widths and alignments. In addition, consult the references listed in Section 1.4.1 for specific requirements not specified in the VTrans Roadway Design Manual.

## **1.3 PLANS PRODUCTION**

Consult the VTrans CADD Manual for guidance on the content of the plans and the presentation of that content.

---

<sup>2</sup> Not yet applicable for railroad bridges.

## **1.4 REFERENCES**

### **1.4.1 Roadway Geometrics**

- The Vermont State Standards for the Design of Transportation Construction, Reconstruction and Rehabilitation on Freeways, Roads and Streets – or simply [The Vermont State Standards](#).
- AASHTO A Policy on Geometric Design of Highways and Streets – or simply AASHTO Green Book.
- AASHTO Roadside Design Guide
- American Railway Engineering and Maintenance-of-Way Association – or simply AREMA.
- [VTrans Policy on Design Exceptions](#)
- VTrans Highway Functional Classification Map
  - <http://www.aot.state.vt.us/planning/documents/highresearch/publications/pub.htm>

### **1.4.2 Structural**

- AASHTO LRFD Bridge Design Specifications – or simply LRFD



## SECTION 2: GENERAL DESIGN AND DETAILS

### 2.1 LOCATION FEATURES

#### 2.1.1 Route Location

##### 2.1.1.1 General

The Geometrics of Design, including roadway widths, horizontal and vertical clearances, shall comply with the latest edition of The Vermont State Standards for the Design of Transportation Construction, Reconstruction and Rehabilitation on Freeways, Roads and Streets. Refer to the AASHTO, A Policy on Geometric Design of Highways and Streets [AASHTO “Green Book”.] for criteria not addressed in the Vermont State Standards.

##### 2.1.1.2 Horizontal Alignment Recommendations

Make every effort to keep the structure entirely on or entirely off horizontal curves.

##### 2.1.1.3 Vertical Alignment Recommendations

Preferably, locate the entire structure either on or off vertical curves. In addition, avoid placing the structure on a sag vertical curve. When the project’s geometry outweighs these concerns, try to keep the low point of the curve off the structure. Further, avoid grades of less than 1.0% if possible.

##### 2.1.1.4 Cross slopes

Refer to the appropriate section of the [Vermont State Design Standards](#) when determining the appropriate superelevation for a site. Each section refers to a different classification of road, in accordance with the Functional Classification of Inventory Route provided by the [FHWA’s Recording and Coding Guide for the Structure Inventory and Appraisal of the Nation’s Bridges](#).

###### 2.1.1.4.1 General Criteria

Follow these general guidelines:

- Any banking transition used on the structure must be a straight line to avoid discontinuities in the deck cross-slope. Avoid banking reversals where possible.
- Whether a gravel road is in a normal crown or banked, the slope used shall continue at a straight line between the centerline and the face of rail. The result will be no break at the theoretical edge of traveled way.
- Design Bridge decks on a straight cross-slope, with no parabolic curve. This applies to all designs, whether on gravel or paved roads.
- For shoulders 6 feet or wider, the shoulder may be broken with its own slope of 4.0%. This applies to the shoulder width on normal sections and if no part of the structure is in transition.
- The slope break behind a guardrail shall be 6%.

#### **2.1.1.4.2 Conditions for Elimination of Superelevation**

Under certain conditions, the designer may eliminate the superelevation on designs of roadways with a design speed of 30 mph or less. Some conditions that might warrant elimination are as follows:

- In urban areas, reduced or no banking may be used at the designer's discretion.
- Proximity to an intersection
- Banking amounts on existing curves at either end of the project

#### **2.1.1.5 Maximum Grades**

Refer to the appropriate section of the [Vermont State Standards](#) when selecting a criterion. If a segment of roadway within the limits of the available survey indicates a grade greater than the maximum specified for "level terrain", consider the terrain as either rolling or mountainous. These tables recommend lower design speed for rolling or mountainous terrain.

### **2.1.2 Clearances**

Navigational clearances for crossings over navigable waterways shall be by permit obtained from the U.S. Coast Guard.

Railroad clearance requirements shall be according to American Railway Engineering and Maintenance-of-Way Association [AREMA] or as required by individual railroad involved.

#### **2.1.2.1 Waterways**

Determine minimum vertical clearances over waterways from hydraulics, geometric and navigational concerns.

Determine minimum horizontal clearance over waterways from the Hydraulic Unit's considerations.

#### **2.1.2.2 Vertical Clearance for National Highway System [NHS]**

All bridges over the National Highway System shall have a minimum vertical clearance of 16.5 feet. When necessary, the designer may request a design exception from the FHWA<sup>1</sup>. The minimum vertical clearance for all other bridges shall be as recommended by AASHTO concerning trusses and girder structures<sup>2</sup>. Vertical clearance is the minimum measurable vertical distance from the underpass roadway surface to the underside of the overpass.

#### **2.1.2.3 Railroads Overpass**

All structures over railroads shall have a minimum vertical clearance of 23'-0", or as otherwise stated in the American Railway Engineering and Maintenance-of-Way Association Specifications (AREMA). If a variance from this case is necessary, refer to 5 V.S.A. § 3670.

5 V.S.A. § 3670 (b): Subject to the approval of the transportation board, a variance from the standards established by this section may be established by written agreement from VTrans, all involved railroad companies and any affected municipality.

Horizontal clearances at highway structures over or adjacent to railroads shall be in accordance to AREMA and are subject to railroad approval.

---

<sup>1</sup> Rentz, Henry H., Vertical Clearance, Interstate System Coordination of Design Exceptions, September 17, 1999. Accompanied form (SDTE-SA) March 19, 2008

<sup>2</sup> AASHTO, Geometric Design of Highways and Streets, Washington, D.C.: AASHTO, 2004: p. 763

### 2.1.2.4 Clear Zones

Safety requirements dictate that the designer maintains a clear zone between the edge of traveled way and any obstructions. The designer shall use the Vermont State Standards, the AASHTO Green Book and AASHTO Roadside Design Guide, where applicable, when establishing the clear zone. The Designer may modify clear zone distances shown in Table 3.1 of the Roadside Design Guide based on accident history, existing conditions, economics, etc. If clear zone distances need modifications, then record the reasons in the design folder.

Show the clear zone distances on the layout sheets and on the typical section at the preliminary plan submittal. Delineate the minimum clear zone distance on the layout by a line consisting of a repeating pattern of two dots and a dash and labeled with a "CZ" ( **•• — CZ •• —** ). The delineation of the clear zone should begin at the "Begin Project Station" and end at the "End Project Station". Do not show clear zone delineation behind bridge rail; the clear zone stops at the beginning of the bridge rail and starts again after the end of the bridge rail.

Clear zones delineation lines shall run parallel to the centerline. The delineation lines shall run perpendicular to the centerline, where the clear zone width changes. Some reasons for changing the clear zone distance include guardrail, change of design speed, climbing lanes or sight distance issues. The clear zone behind guardrail will be the dynamic deflection distance. However, the full clear zone distance should extend approximately 50 feet along the guardrail from the terminal end.

### 2.1.3 Bridge Typical Section

The clear width is the measurement between the faces of bridge railing. (See LRFD 3.6.1.1.1). The bridge width shall be the fascia-to-fascia width. For more dimensions, see Figure 2.1.3 -1.

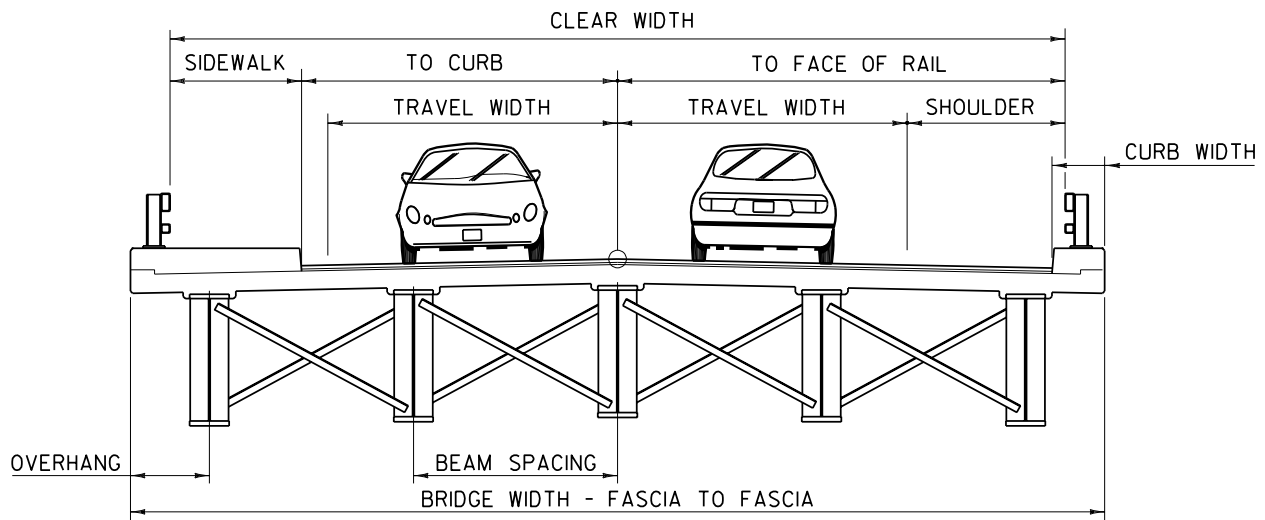

Figure 2.1.3 -1 Bridge Typical

- Refer to the Bridge Inspection Files for the bridge functional classification. VTrans Functional Classification Maps published in 2004 or after, shows State and Town Highways that are on the Federal or State system in various classifications:
- Principal Arterial such as Interstate, Freeways
- Minor Arterial
- Major Collector
- Minor Collector

- The Agency refers to Town Highways on the Federal system as Federal Aid Secondary (FAS) routes
- Town Highways not shown on the map that are not on the State System are “Local Road”
- Use the design criteria in the Vermont State Standards for the highway classification shown on the map for the highway in question. If the Functional Classification Map does not include the roadway, consider it a “Local Road” as specified in [Section 6.0](#) of the Vermont State Standards, giving focus to the requirements of Section 6.14.
- Use [Table 6.3](#) of the Vermont State Standards to select the bridge width on local roads. Use [Table 5.3](#) to select the widths for bridges on collector highways.
- Any new bridge not meeting the minimum width from the appropriate table requires an approval as a design exception. See Section 2.2.1.
- On a local road with an ADT of up to 50 or for roadways not shown on the Functional Classification Map, consider using a design exception allowing the use of a one-lane bridge, a minimum of 16' (for farm or other large equipment). See Section 2.2.1.
- Use the projected [future] ADT and DHV traffic information for width selection. Provide the best estimate of the construction year when requesting traffic data. The design year will be 10 years beyond the estimated date for rehabilitation projects and 20 years beyond for new construction.
- In general, use sidewalks only where sidewalks exist on the approaches or on the existing bridge. At times, local needs may require adding a sidewalk where none existed or vice-versa.

### 2.1.4 Project Limits Definition

A project approach begins at the point of cold planning and ends at the point where the full depth construction begins. Begin and end of project begins at the point of full construction depth and ends at the point where the full construction depth starts to transition. See Figure 2.1.4 -1. Attempt to keep these locations to the nearest 10 feet.

Minimum approach lengths typically extend 50 feet beyond the back of abutment. The designer shall provide a transition detail from the bridge width to the existing roadway width. The maximum rate of width transition is 1:25.

Properly indicating these locations on the plans will help a future designer tie in their project to the current project. The proper location of these points also aid in writing permits during the project scoping process.

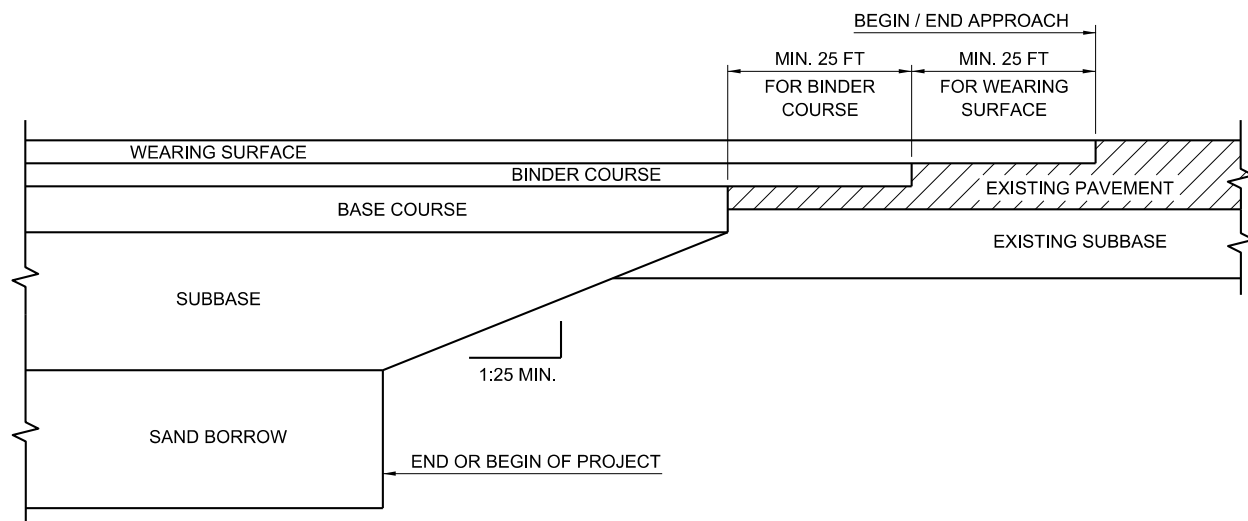

Figure 2.1.4 -1 Approach Detail

## **2.2 DESIGN OBJECTIVES**

The designer will gather a variety of information as described in this Section and summarize this information on a Design Criteria Sheet. The designer will use these criteria to determine the need for any exceptions.

### **2.2.1 Design Criteria Sheet**

Use reasonable engineering judgment in the application of the Vermont State Standards and the AASHTO Green Book guidelines. Prepare a Design Criteria Sheet for each project, to place in the front of the design folder. On this design criteria sheet, list the following:

- Traffic Data (ADT, ADTT, etc)
- Design speed and the reason for its selection. Include the references to the appropriate tables in the Vermont State Standards and the Green Book.
- Horizontal and vertical alignment criteria, using references to the Vermont State Standards and the Green Book as necessary
- Determination of typical approach roadway and bridge sections
- Maximum banking with reference to the appropriate tables. Include any notations as to conditions that have warranted elimination or modification of the banking.

The Structures Section allows minor deviations from the accepted standards listed in section 2.1.1.1 with sufficient justification and with an approved design exception. The Vermont State Standards supersede the AASHTO Green Book, therefore design exceptions will only be necessary in those situations where the design criteria do not fall within the acceptable range of possible values and combinations covered by The Vermont State Standards. Refer to the VTrans Policy on Design Exceptions for more information and the process for obtaining an exception.



## 2.3 BRIDGE LAYOUT PROCEDURES

### 2.3.1 Working Points

Use Working Points (WP) for aiding field staking and layout. Bridge plans show Working Points along the centerline with stations and elevations. In some cases, the plans may also show northing and easting coordinates. The plans show all other working points, such as those for substructure units, as dimensioned from the centerline working points along a line defined at an angle from the bridge chord. Three working points usually define the basic layout of each substructure unit. Figure 2.3.1-1 through Figure 2.3.1-3 show the layout of various bridges.

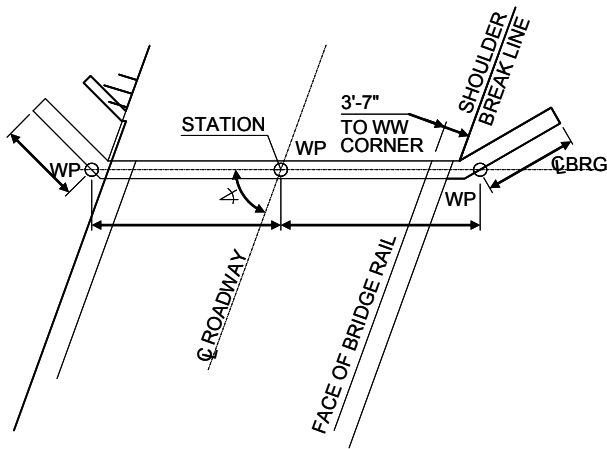

Figure 2.3.1-1 Deck on Beam Bridge Layout

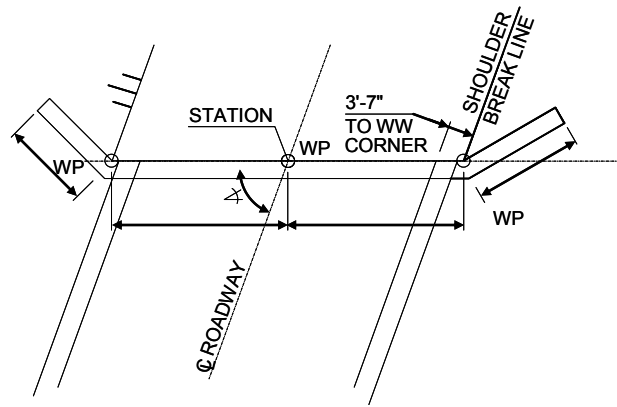

Figure 2.3.1-2 Concrete Slab, Two Cell Box or Two Cell Frame

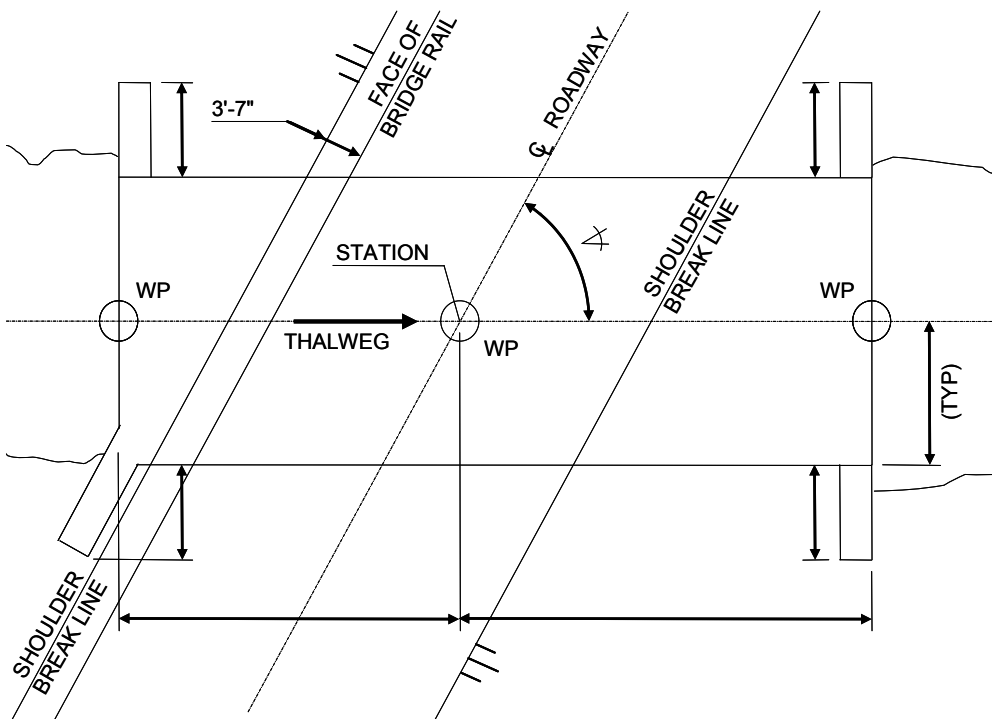

Figure 2.3.1-3 Pipe, Small Box or Small Frame

## 2.3.2 Skew and Askew

### 2.3.2.1 Skew

Skew ( $\Theta$ ) is the angle between the centerline of a support and a line normal to the bridge chord. See Figure 2.3.2-1. For curved beam bridges, measure the skew from the radial line crossing the intersection of the bridge chord and centerline of substructure, to the centerline of substructure.

### 2.3.2.2 Askew

Askew is the compliment angle of the skew. See Figure 2.3.2-1.

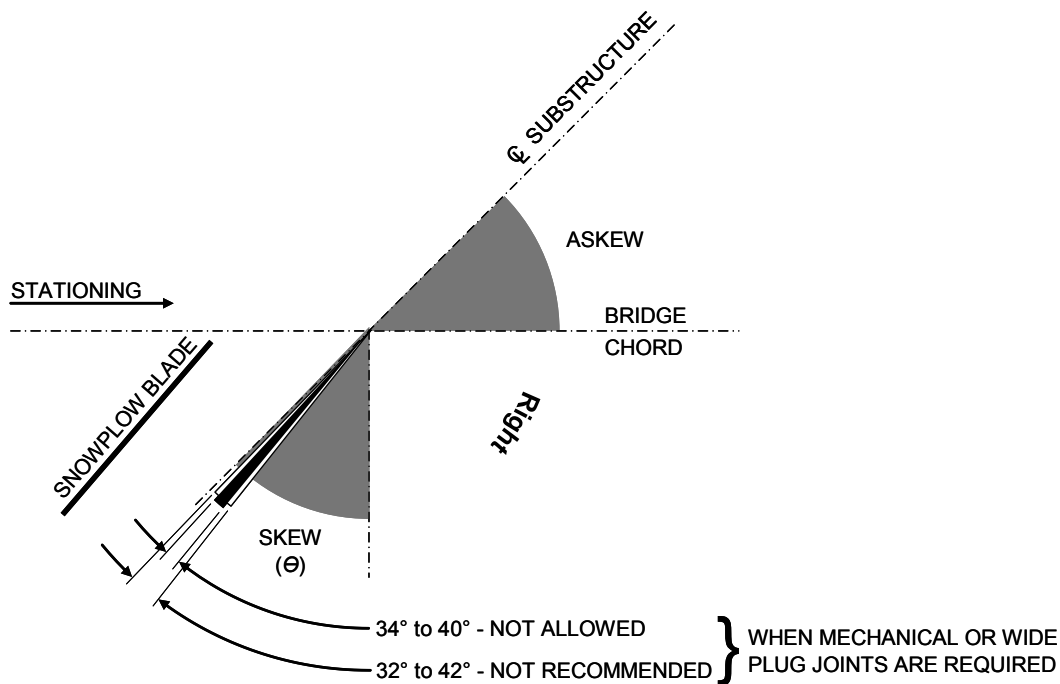

Figure 2.3.2-1 Skew and Askew Definition

### 2.3.2.3 Bridge Joint Skew Restrictions<sup>3</sup>

The VTrans Operations Division currently uses snowplows that have a horizontal blade angle of 36.5° to 37.5° right, measured from a perpendicular to the long axis of the plow vehicle. In situations where the angles of the snowplow blade and bridge joint are nearly the same, the blade will likely damage the bridge joint. The blade catches on the mechanical parts of the joint such as angles or plates as well as gouging out the joint material of the wide pavement joints. This situation can also result in significant damage to the plow and/or truck and may cause harm to the snowplow operator.

The designer must also consider other factors regarding the alignment of the snowplow blade with the bridge joint. Such factors include the width of the bridge joint; the plow truck path may not necessarily align with the bridge centerline when it passes over the joint or snowplow blades may be slightly misaligned.

<sup>3</sup> Policy as stated in Structures Engineering Instructions 08-003 (3/31/08)

In consideration of these variables, the following skew restrictions apply on new bridges when mechanical or wide plug joints are required: (See Figure 2.3.2-1)

- Skews ( $\Theta$ ) not allowed: 34° to 40° to the right
- Skews ( $\Theta$ ) to avoid: 32° to 34° and 40° to 42° to the right

Because Local municipalities utilize equipment that is similar to that used by the VTrans Operations Division, these restrictions apply to all bridges designed for all of the bridge programs. The Structures Section extends these restrictions to left skews for bridges on the Interstate System, or other divided two-lane highways, which requires maintenance using left angled plows.

The Structures Section does not restrict the skew when using narrow saw cut pavement joints for bridge projects. The skew ( $\Theta$ ) restrictions do not apply for rehabilitation bridge projects.

Bridges that have skew angles within the restricted range, either a bridge rehabilitation project or a new bridge design which have a skew restriction exemption, the bridge joint shall be marked with delineators designed in consultation with the Operations Division. In these special cases, the designer should consider design features that minimize possible damage to the joint and maintenance equipment.

### **2.3.3 Deck on Beam Structures**

For bridges with beams or girders, lay out the abutments from the centerline of bearings. A working point shall be located at the intersection of the roadway centerline and the bearing centerline. Identify an additional working point where the centerline of bearing intersects the exposed face of each wing wall. Dimension the wing wall lengths from these right and left working points, to the end of the wing walls. See Figure 2.3.1-1.

### **2.3.4 Concrete Structures**

Cast-in-place concrete slab structures, precast concrete slab structures, large concrete boxes and concrete rigid frames shall be laid out from the abutments or outside walls from the begin and end bridge points extended along the back face. Working points shall be located at the bridge begin and end points along the centerline of the roadway. Additional working points shall be located where the back of the abutments and the inside of the wingwalls meet at the top of footing for either side of the abutment. Dimension the wing wall lengths from these right and left working points to the end of the wing walls. See Figure 2.3.1-2.

### **2.3.5 Pipes, Small Boxes and Small Frames**

For corrugated plate arches, pipes, or pipe arches; small concrete boxes or small concrete frames, lay out the structure from the intersection of the roadway centerline and the centerline of structure. A working point shall be located at this intersection. The centerline of the structure should closely approximate the thalweg of the river or the approximate centerline of the stream. Show the dimensions left and right from this working point to the ends of the structure. Dimension the ends of the wing walls from the edge of the structure. See Figure 2.3.1-2 and Figure 2.3.1-3.

## **2.4 BRIDGE TYPES**

### **2.4.1 Integral Abutment**

Integral Abutment bridges encapsulate all other bridge types. Substructures and the superstructure of an integral abutment bridge are monolithic, thereby eliminating joints and bearings. The Agency considers the integral abutment as the primary choice for bridges in the state. If site conditions do not permit an integral abutment to be constructed, consider other bridge types.

### **2.4.2 Concrete Slab Bridge**

These include cast-in-place concrete or butted prestressed concrete deck beams. Spans are typically short.

### **2.4.3 Covered Bridge**

Historically, an all timber structure comprised of side trusses; a deck built up with floor beams topped with runners; and a roof system. Typically, timber sheathing covers the trusses; however, some covered bridges have exposed trusses. Over time, the Agency has renovated several covered bridges. Some of these bridges have received a steel girder/timber deck system leaving the timber trusses and roof structure self-supported.

### **2.4.4 Steel Truss**

Steel trusses are comprised of two similar truss structures connected by floor beams and a system of overhead sway bracing. In the past, the Agency used steel truss structures in locations where site conditions required long spans and maximized clear depths.

### **2.4.5 Straight Beams and Girders**

This is a system of steel or prestress beams topped by a concrete deck. This bridge configuration makes up the majority of the federal and state system. Typically, if a simple concrete slab will not be sufficient as the superstructure for the bridge; straight beam framing will be the next alternative to explore.

### **2.4.6 Curved Beams and Girders**

Beams configured similar to Section 2.4.5, however curved with the roadway alignment. Use curved beams only where straight beams are impractical or produce an unacceptable overhang. Ideally, the substructures are radial however, some have skewed substructure.

### **2.4.7 3-Span Continuous Cantilever Bridges**

A 3-Span continuous cantilever bridge has modified abutments attached to and supported by the superstructure. All abutment dead loads, superstructure dead loads, and live loads are then supported by two piers. This type of design allows a maximizing of the center span over the stream combined with some of the economics of a continuous design. The ideal span ratio is around 1 – 5 – 1.

## ***2.5 BRIDGE END DETAIL SCHEMATICS***

Integral abutment construction shall be considered as the first alternative for all concrete slab and concrete deck on steel beam or prestressed concrete beam bridges during the Project Definition Stage for Structure Section projects. Project Managers shall document the reasons for not selecting the integral abutment bridge type in a Scoping Report or in a memo from the Project Manager to the Structures Program Manager.

Avoid using expansion joints, if possible. If the design requires the use of expansion joints, the selection of the joint type is dependent on the length of span and total movement required.

### **2.5.1 Location of Expansion Joint**

See Section 4.4 for a discussion of location of fixed and expansion joints.

Avoid open expansion joints at piers.

### **2.5.2 Selection of Bridge End Detail**

Refer to Figure 2.5.2-1 to assist in selecting the appropriate bridge end detail for superstructures constructed from cast-in-place concrete slabs, prestressed concrete butted or spread beams, prestressed NEXT beams or steel beams. For timber, superstructures refer to Section 8 for bridge end details. Sections 2.5.2.1 to 2.5.2.9 guide the designer in selecting the proper end of bridge details and expansion joints. The details in this section show the bridge end details with exposed concrete decks. For paved deck or exposed concrete deck options, refer to Section 2.7. The designer shall refer to Section 5 and Section 6 for detailed information regarding the various decking options.

### **2.5.2.1 Type A**

Use the Type A bridge end detail for Integral Abutment bridges with approach slabs. For short spans, use the Type C bridge end detail as an option. See Figure 2.5.2.1 -1.

### **2.5.2.2 Type B**

A Type B bridge end detail is similar to Type A (See Section 2.5.2.1) for an integral abutment end detail however without approach slabs. See Figure 2.5.2.2 -1.

### **2.5.2.3 Type C**

Use the Type C bridge end detail for fixed and expansion ends for short spans with approach slabs, with cast in place concrete or precast voided slab decks. Use this bridge end detail for short span integral abutment bridges as well. See Figure 2.5.2.3 -1.

### **2.5.2.4 Type D**

Use the Type D bridge end detail for fixed and expansion ends for short spans without approach slabs, including cast in place concrete slabs, precast voided slabs and box beam decks. Use this bridge end detail for short span integral abutment bridges as well. See Figure 2.5.2.4 -1.

### **2.5.2.5 Type E**

A Type E bridge end detail applies to both fixed and expansion ends for intermediate spans using spread beams without approach slab. See Figure 2.5.2.5 -1

### **2.5.2.6 Type F**

A Type F bridge end detail applies to fix and expansion ends of intermediate spans using spread beams with approach slab. See Figure 2.5.2.6 -1.

### **2.5.2.7 Type G**

Use a Type G bridge end detail for the fixed end of spread beam decking on long spans with approach slabs. For butted box beam decks, use this bridge end detail for the fixed end, when skews are greater than 30°. See Figure 2.5.2.7 -1.

### **2.5.2.8 Type H**

Use a Type H bridge end detail for the expansion end of spread beam decking on long spans with approach slabs. For butted box beam decks, use this bridge end detail for the expansion end, when skews are greater than 30°. See Figure 2.5.2.8 -1.

### **2.5.2.9 Type I**

Use a Type I bridge end detail for spread beam decking of long spans without approach slabs. For butted box beam decks, use this bridge end detail for the expansion end, when skews are greater than 30°. Specify this bridge end detail for both fixed and expansion ends on gravel roadways. Use this detail for the fixed end and the Type H detail for the expansion end on paved highways. See Figure 2.5.2.9 -1.

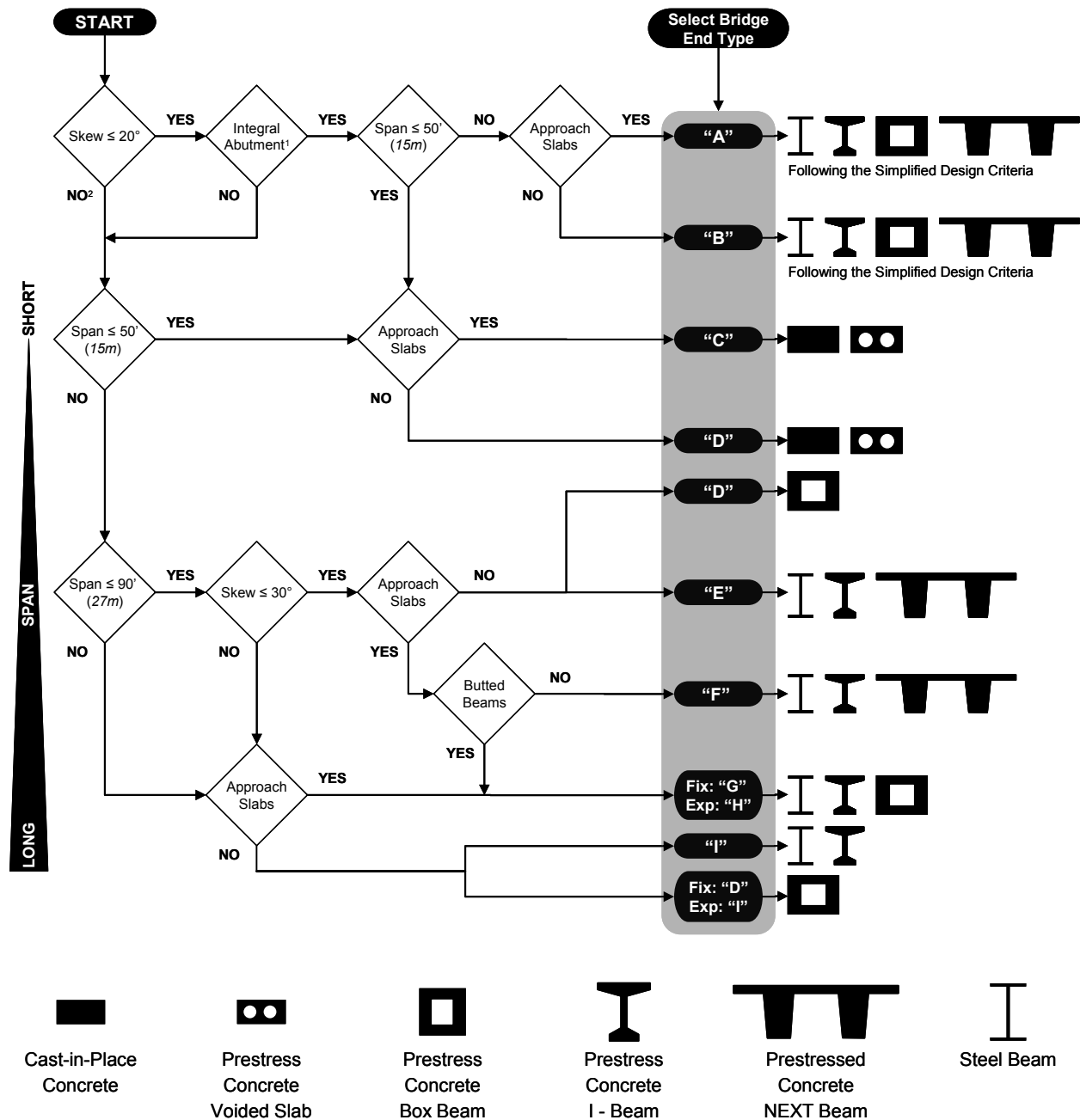

1. Integral Abutments shall be the first choice when selecting a bridge type. This flow chart only addressed the simplified design method as presented in the VTrans Structures' Integral Abutment Design Guide. For bridges that do not comply with the criteria for the Simplified Design Method, use additional considerations to design them with Integral Abutment.

2. Though the skew exceeds  $20^\circ$ , using Integral Abutments is possible using additional design considerations

Figure 2.5.2-1 Flowchart Used for Selecting End of Bridge Details

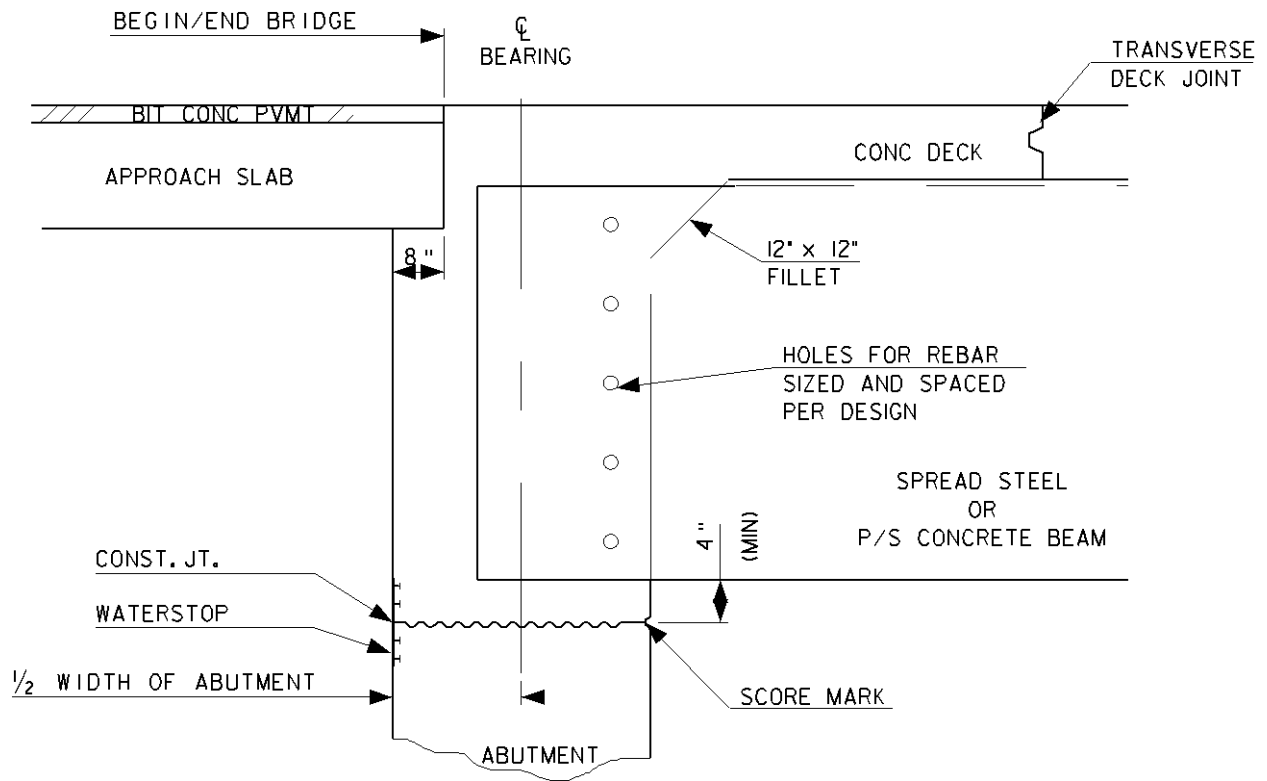

Figure 2.5.2.1 -1 Type A – Bridge Ends for Integral Abutment Bridges with Approach Slabs.

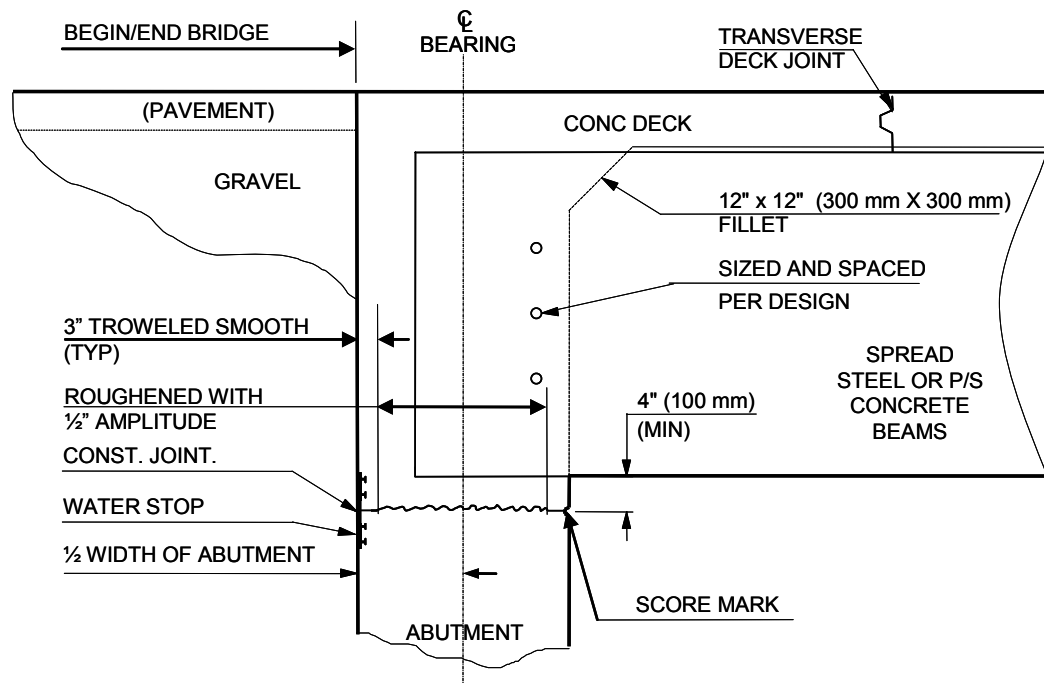

Figure 2.5.2.2 -1 Type B - Bridge Ends for Integral Abutment Bridges without Approach Slabs.

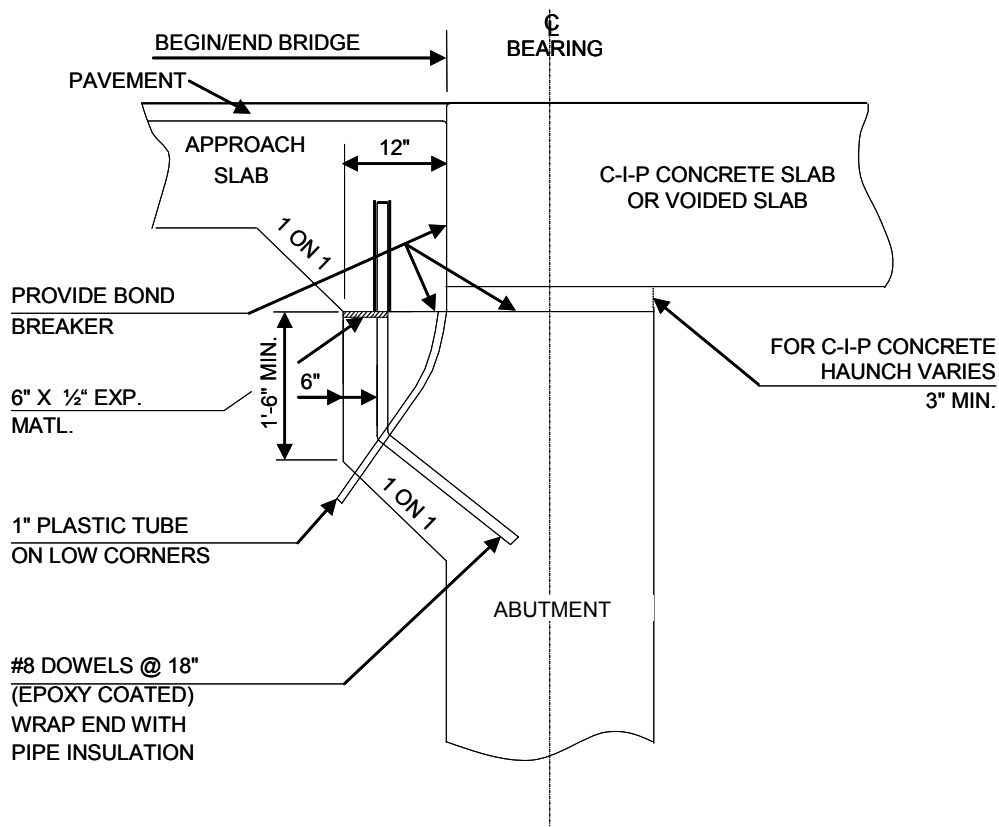

Figure 2.5.2.3 -1 Type C – Bridge Ends (both abutments) for short spans with Approach Slabs.

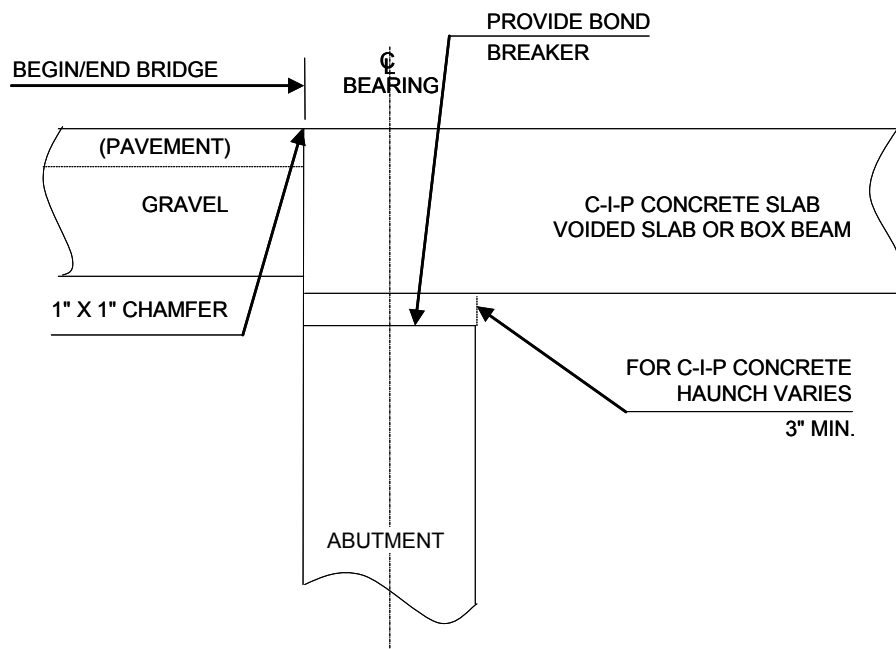

Figure 2.5.2.4 -1 Type D - Bridge Ends for short spans without Approach Slabs.



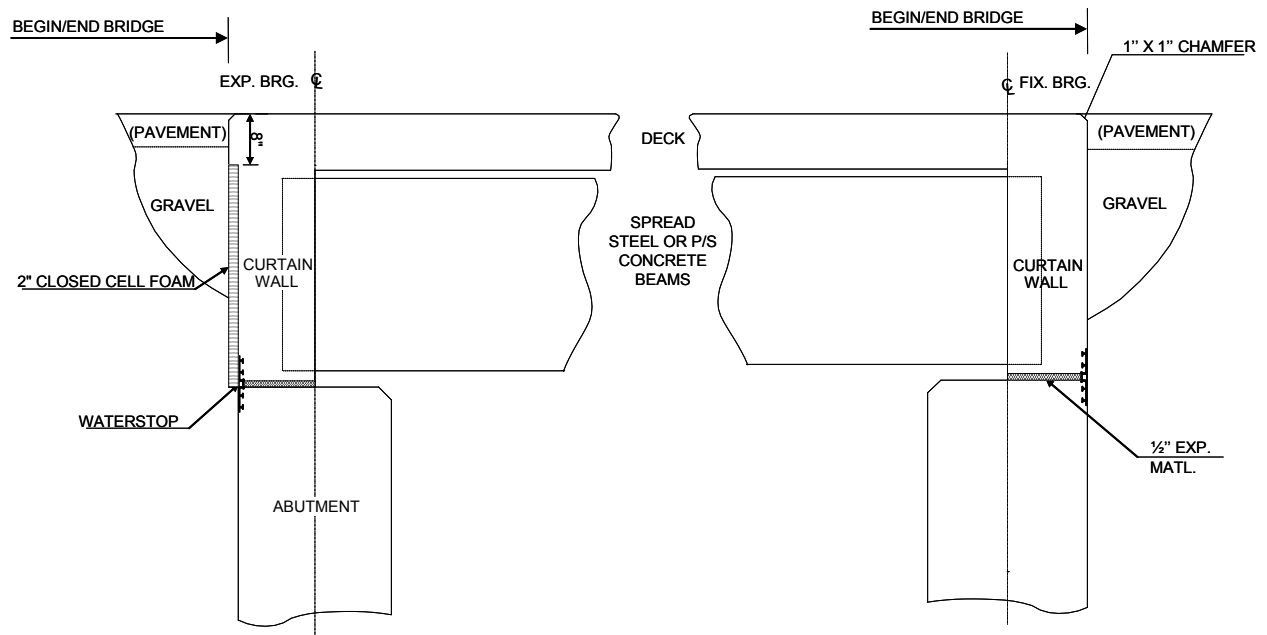

Figure 2.5.2.5 -1 Type E – Bridge Ends for intermediate spans without Approach Slabs.

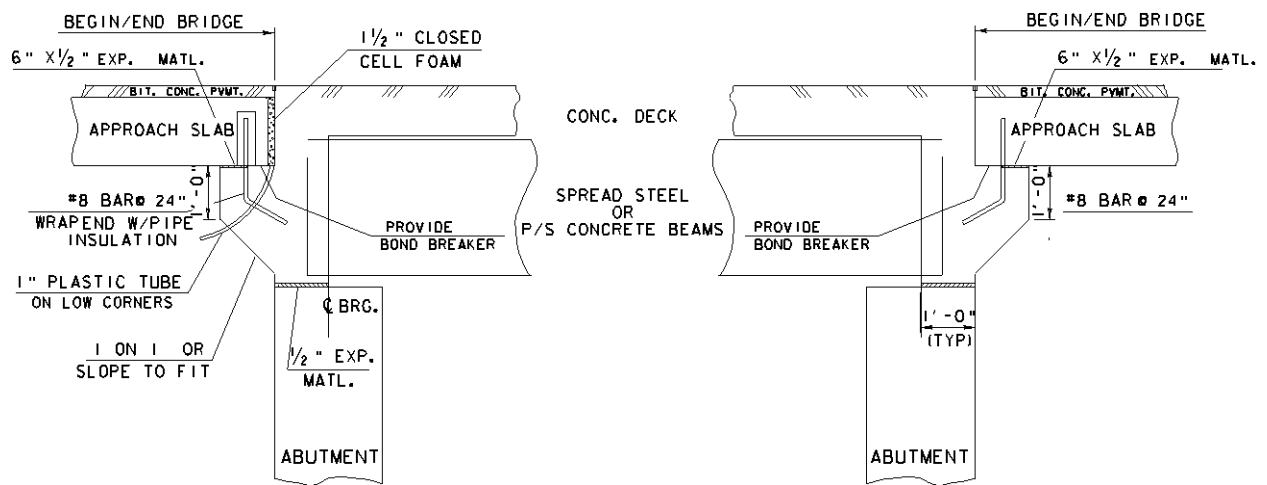

Figure 2.5.2.6 -1 Type F – Bridge Ends for intermediate spans with Approach Slabs.

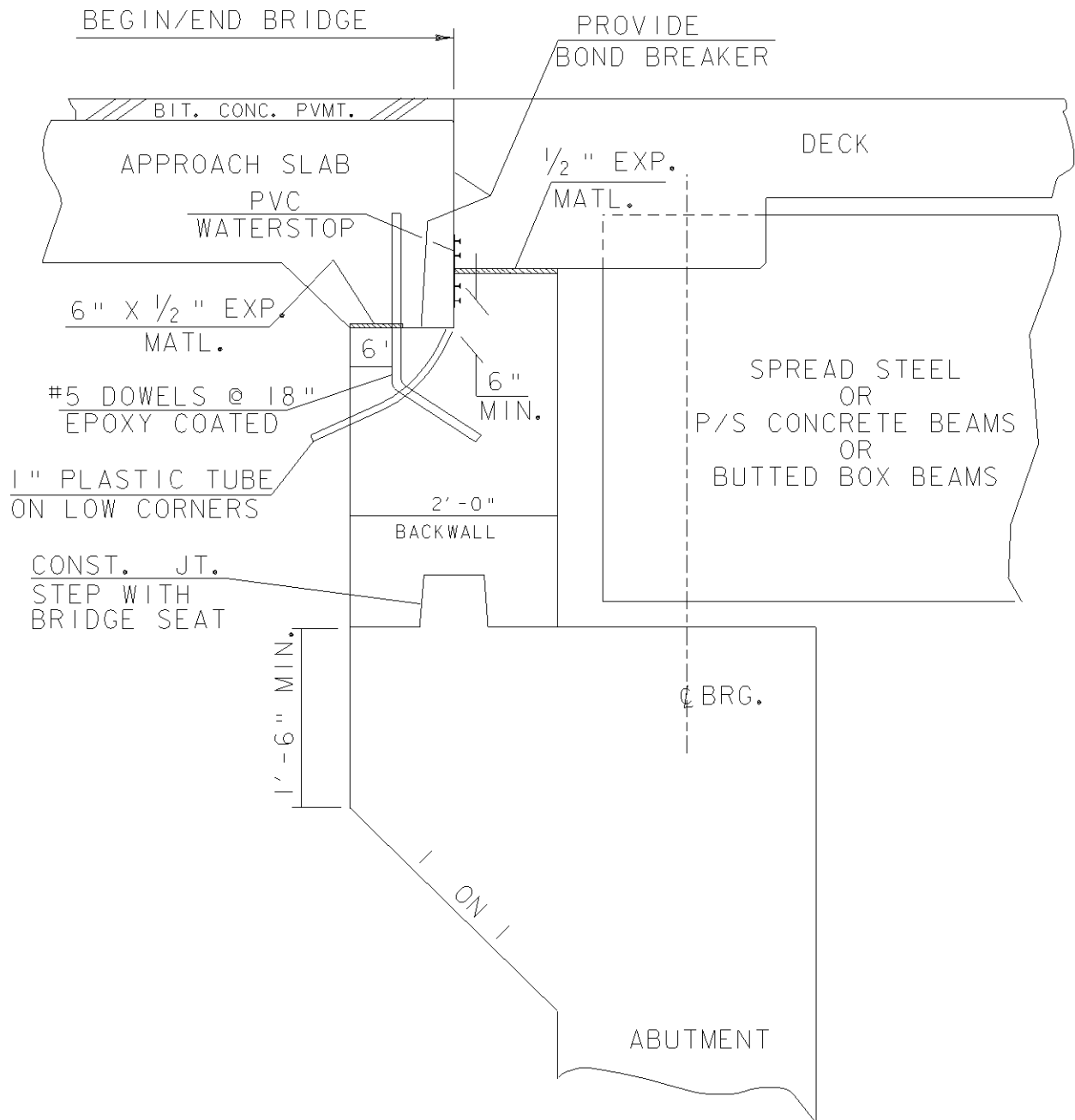

Figure 2.5.2.7 -1 Type G – Bridge End for Long Spans with Spread Beam Decking or Intermediate Spans with Butted Box Beams decking, both with Approach Slabs.

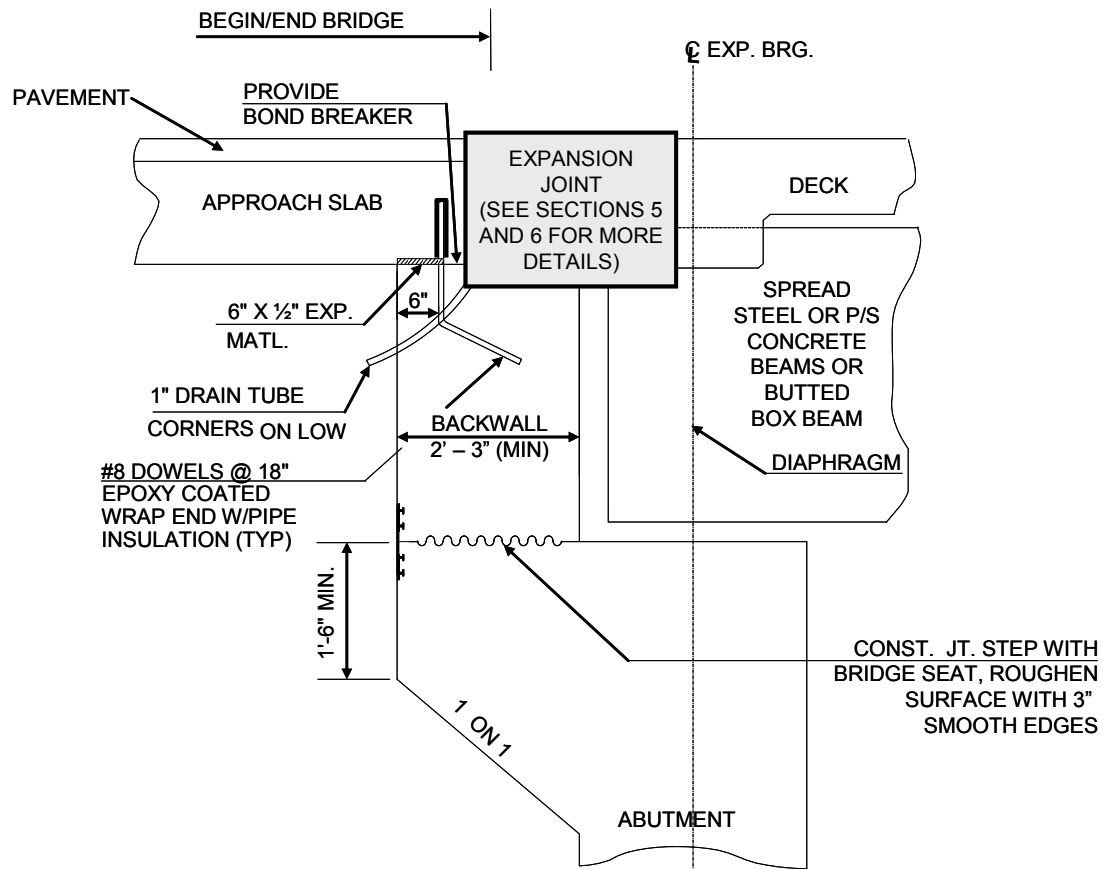

Figure 2.5.2.8 -1 Type H – Bridge End for Long Spans with Spread Beam Decking or Intermediate Spans with Butted Box Beams decking, both with Approach Slabs.

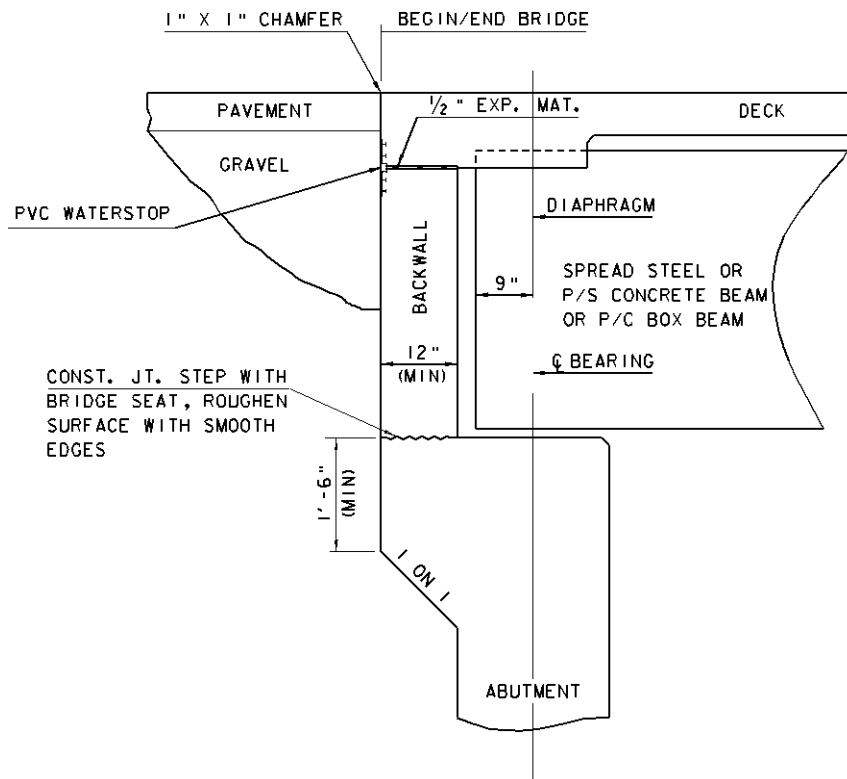

Figure 2.5.2.9 -1 Type I – Expansion and Fixed Bridge Ends for Long Span Spread Beam Decking without Approach Slabs of any skew or for the Expansion End of Butted Box Beam Decks with skews greater than 30°.

### 2.5.3 Bare and Paved Concrete Deck Details

The designer shall consider a bare deck initially. When specifying a paved deck in the plans, the bridge end details will require additional pavement details.

#### 2.5.3.1 Bare Concrete Deck Details

For deck thicknesses refer to Section 5.2.1.1.1. The concrete surface will require special treatment to ensure there will be adequate traction. This treatment will include applying a texture during the screeding of the deck, and may include grooving the deck once the concrete cures. Use the details above as well as those in Sections 5 and 6 as presented.

Grooving of the deck is used to provide appropriate friction for dry and wet pavement while still keeping a low-noise surface. A proper combination of macrotexture and microtexture (wavelengths of 0.5mm to 50mm and 1µm to 0.5mm, respectively) while limiting megatexture (wavelengths of 50mm to 500mm) can provide the texture needed for both adequate wet pavement friction and low noise. All bare concrete decks shall, as a minimum, have the surface textured by means of a broom finish. Bridges with design speeds greater than 45 miles per hour or with a radius of curvatures less than 1640 feet shall also be tined or grooved. Other situations may warrant tining or grooving the bridge deck.<sup>4</sup>

<sup>4</sup> Surface Texture for Asphalt and Concrete Pavements: <http://www.fhwa.dot.gov/pavement/t504036.cfm>  
Surface Finishing of PPC Pavements: [http://www.fhwa.dot.gov/legsregs/directives/policy/sa\\_96\\_06.htm](http://www.fhwa.dot.gov/legsregs/directives/policy/sa_96_06.htm)

### 2.5.3.2 Paved Deck Details

When topping a bridge deck with bituminous concrete pavement, detail the application of a sheet membrane waterproof layer on the concrete surface. Detail the application of pavement in two layers of Type IV (Marshal) or Type IVS (superpave) pavement. Use a saw cut joint (see Section Pavement Saw Cut Joint) at fixed ends of bridges and joints between the deck and approach slab for integral abutment bridges. A saw cut joint will provide better control in pavement cracking at these locations thereby avoiding network cracking.

Where expected expansion exceeds  $\frac{1}{8}$  inch, use an asphaltic plug joint (see Section 14.2.1.3 ). The asphaltic plug joint will accommodate expansion up to 1 inch. When the expected expansion movement exceeds this, a mechanical expansion device will be required. Use an asphaltic plug joint at the ends of approach slabs for integral abutment bridges to accommodate the relative movement at this location. See Sections 14.2.1.1 and 14.2.1.2 . In this case, the expansion device should be preceded by and followed by an 11 inch wide raised concrete step, the height of the pavement plus up to  $\frac{1}{8}$  inch. Detail the sheet membrane waterproofing and pavement up to and from the vertical faces of these steps.

The bridge end details presented in Section 2.5.2, as well as those presented in Sections 5 and 6 require additional detailing to show the pavement application requirements.

### 2.5.4 Prestressed Concrete Issues

- Design and install abutment back walls for all box beams with approach slabs and for those without approach slabs, when the skews are  $30^\circ$  or greater. For 27 inches deep box beams, the designer may use the voided slab end details when an approach slab is present.
- Anchor bolts, steel plates, nuts, and washers shall be paid for as part of Item 510.20, Prestressed Concrete Member and shall meet the following requirements:
- Anchor bolts shall be swedged and galvanized, threaded for 12 inches.
- Each anchor bolt shall have a single nut. On the expansion end, the Contractor shall hand tighten the nut and then loosened it by  $\frac{1}{2}$  turn. On the fixed end, the Contractor shall tighten the nut.
- All anchor bolts, and nuts shall be ANSI A449, and all washers shall be AASHTO M270 Grade 50, unless otherwise noted.

## 2.6 APPROACH SLABS

### 2.6.1 When to Use

Use paved at grade approach slabs on all projects where the design requires a paved surface and the projected ADT is more than 400. The length of the approach slab depends on the skew of the bridge (See Table 2.6.1 -1).

### 2.6.2 Approach Slab Details

- Refer to Figure 2.6.2 -1 for approach slab details
- Place the slab under the travel lanes and shoulders
- Run longitudinal reinforcement parallel with the centerline of the roadway
- Run Transverse reinforcement parallel with the centerline of bearing
- Pave the approach slabs with the top two lifts (approx. 3" ) of roadway bituminous concrete pavement
- At grade approach slabs shall follow the criteria in Table 2.6.2 -1

LONGITUDINAL REINFORCEMENT TO RUN PARALLEL WITH THE CENTERLINE OF ROADWAY. TRANSVERSE REINFORCEMENT TO RUN PARALLEL WITH THE CENTERLINE OF BEARING.

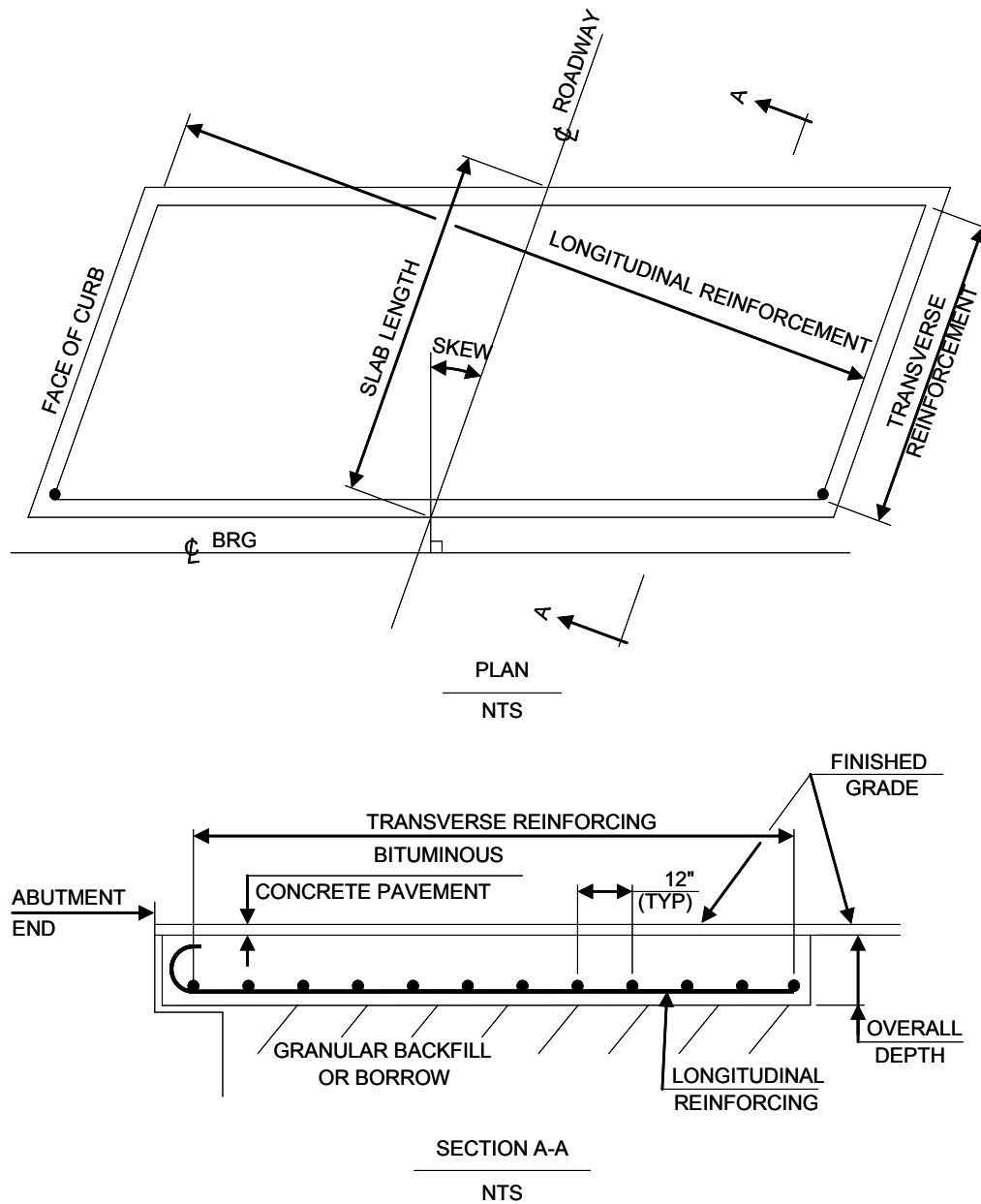

Figure 2.6.2 -1 Approach Slab Detail

Table 2.6.1 -1 Approach Slab Lengths

Skew	Traffic Volume	Slab Length parallel to Centerline
0 to 19°	ADT < 1,000	15'-0"
	ADT ≥ 1,000	20'-0"
20 to 34°	All	20'-0"
35 to 90°	All	25'-0"

### 2.6.3 Approach Slab Properties

Structures suggest using the following properties for the approach slab (See Section 5 for more information on concrete design):

- 3” of pavement
- $f_y = 60$  ksi and  $f'_c = 3.5$  ksi
- Design Span =  $L - 0.5 * [0.25 * L + \text{Abutment Bracket}]$
- Slab on Soil Bearing area is 25% of slab length
- Abutment Bracket = 12 inches
- L = overall length in feet
- AASHTO 4.6.2.3 “Equivalent Strip Width for Slab Type Bridges”
- Impact = 33%
- Bottom reinforcing steel cover is 3 inches

Table 2.6.2 -1 Approach Slab Depth & Reinforcement

Slab Length (L)	15'-0"	20'-0"	25'-0"
Slab Depth	14"	15"	16"
Bottom Longitudinal Reinforcement	#6 @ 6" Epoxy	#9 @ 10" Epoxy	#9 @ 9" Epoxy
Bottom Transverse Reinforcement	#5 @ 12" Epoxy	#5 @ 12" Epoxy	#5 @ 12" Epoxy

## 2.7 PAVEMENT DESIGN

### 2.7.1 Roadway Pavement Considerations

Follow the VTrans Simplified Pavement Design Procedure for low volume roads (Town Highway Projects). For higher volume roads, the designer may use AASHTO's Darwin Software for pavement designs. The Highway Safety and Design Section will provide pavement design assistance based on project information the Project Engineer sends them.

### 2.7.2 Pavement Thickness on Bridge Decks

Applying pavement to any deck surface has proven to be difficult. It is difficult to get proper compaction when paving bridge decks. Aggregate size is a factor in the quality of compaction. Large size aggregate tends to slide around rather than interlock, resulting in a shortened pavement life. Moreover, this creates maintenance problems that could have been otherwise avoided with a bare deck.

Situations where the designer shall consider paving bridge decks are as follows:

- Butted prestressed voided slab or box beam bridge decks without an overlay
- Post-tensioned full depth precast deck panels over beams
- Accelerated Bridge Construction when cracks in the deck are anticipated

On all bridge projects specifying a paved deck, use an applied membrane between the deck and the pavement. At this time, the preferred pavement mix is Bituminous Concrete Pavement Type IVS, also referred to as superpave; however, Marshal Mix (Type IV) may also be specified. Typical total pavement thickness on new bridge projects is 3 inches, placed in two lifts of 1½ inches for Type IVS each, or a total thickness of 2½ inches placed in two lifts of 1¼ inches for Type IV each.

Design all decks with a wearing surface dead load according to Section 3.3.2 Design Pavement Thickness.

### **2.7.3 Pavement Thickness on Approach Slabs**

Detail all approach slabs as paved, however, without an applied membrane. Approach slab surfaces are often rough and are not screeded to the same precision as the bridge deck.

The thickness of the approach slab pavement on bare decks shall meet the following criteria:

- A minimum of two lifts of pavement – 1¼ inches each for Type IV.
- Roadways designed with the Simplified Design Procedure for Bridge Projects shall continue the two top lifts of Type IVS or Type IV over the approach slabs.
- For projects with a specific pavement design, continue the full depths of Type III or Type IV lifts over the approach slabs with consideration of the first bullet.

For paved decks, the thickness of the approach slab pavement shall match the bridge pavement thickness (see Section 2.7.2).

### **2.7.4 Prestressed Concrete Deck Beams or Slabs**

For Prestressed, butted-beam decks constructed on gravel town highways, the designer may choose between a bare concrete deck overlay and pavement on a waterproofing membrane without an overlay.

For Prestressed multi-beam deck units on low volume paved town highways, the designer may choose to eliminate the concrete overlay and use a waterproofing membrane and pavement.

### **2.7.5 Cold Planing**

The designer will include the item for Cold Planing Bituminous Concrete Pavement on all paved projects on Class I Town Highways. Evaluate the use of cold planing for Class II and III Town Highways on a project-by-project basis. Normally, the procedure is to stagger the wearing surface course and binder course by extending both into the existing pavement area. See Figure 2.1.4 -1.

### **2.7.6 Sand Borrow Substitution<sup>5</sup>**

The following note shall be added to any project using the sand borrow item:

'The Contractor may substitute subbase material for the sand borrow shown on the Plans. The subbase material shall meet the type specified in the Contract and placed to meet the subbase specifications. If placement of subbase is in lieu of sand borrow, place a geotextile meeting the requirements of item 649.11 "Geotextile for Road Bed Separator" between the subgrade and the subbase material. All costs associated with the substitution including the geotextile shall be incidental to 203.31 "Sand Borrow".'

For projects in the early stages of design, the designer should consider using the subbase material in lieu of the sand borrow to achieve the necessary frost protection. In this case, the designer should specify the use of a roadbed separator geotextile between the subbase and subgrade and that work paid under the item 649.11 "Geotextile for Road Bed Separator".

---

<sup>5</sup> Policy as stated in Structures Engineering Instructions 09-002 (3/4/09)



## 2.8 GENERAL EARTHWORKS DETAILS

### 2.8.1 Cofferdam Section

Show details and notes, if needed, on the plans according to the following:

When specifying a cofferdam on the plans, VTrans will be paying for all excavation and removal of existing structure within the defined limits of the cofferdam under "Cofferdam Excavation – Rock".

VTrans will pay for any removal of existing structure outside the limits of the cofferdam and within the limits of the appropriate unclassified excavation item. Clearly define the limits for these items on the plans.

Specify that the payment for any portion of the existing structure requiring removal, which falls outside the limits of the excavation items, will be made under either "Removal of Structure" or "Partial Removal of Structure".

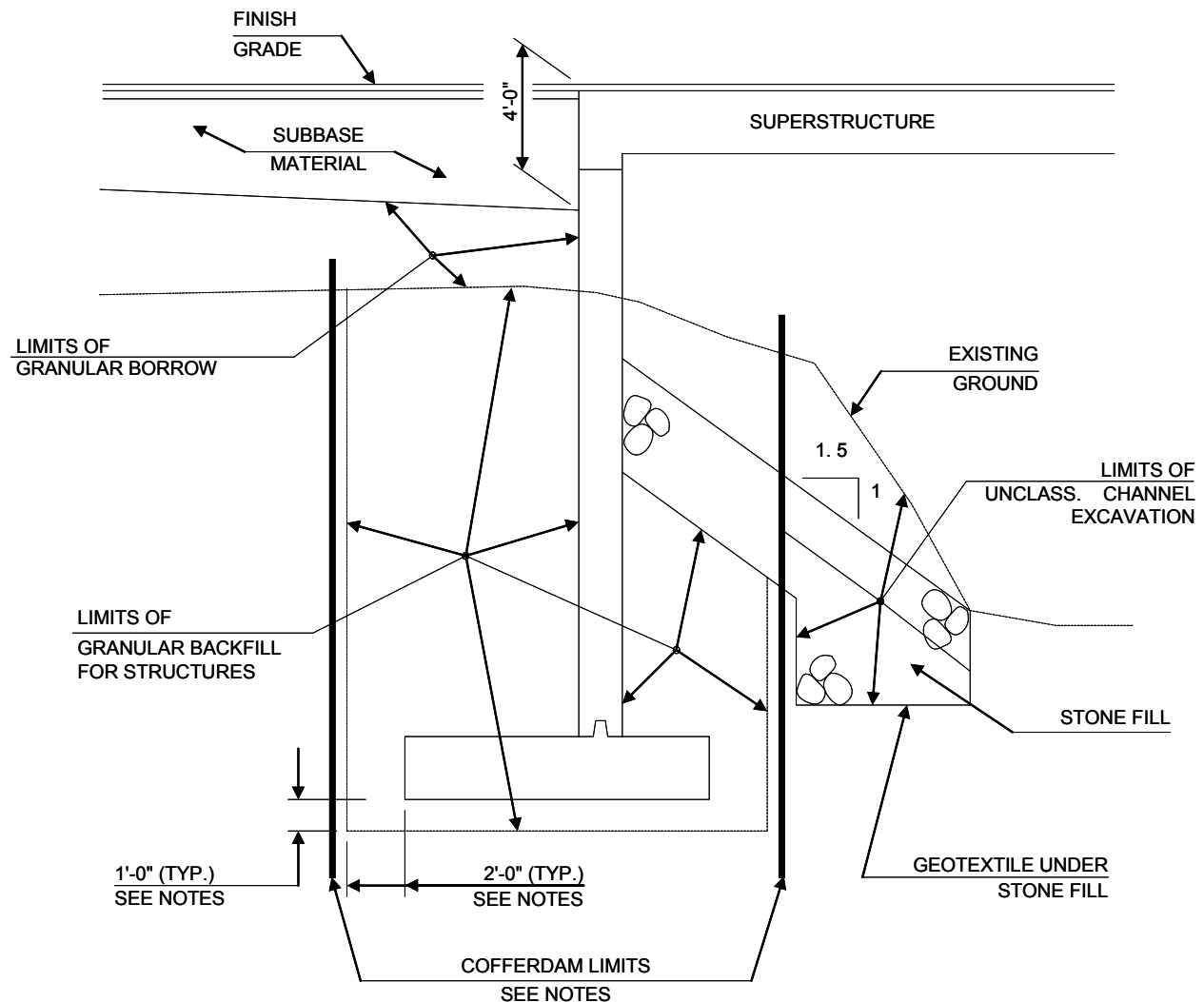

Figure 2.8.1.1-1 Typical Abutment Section Showing Cofferdam

### 2.8.1.1 Cofferdam Notes

Place the following cofferdam limits notes on the plans as they apply to the project, along with Figure 2.8.1.1-1.

- The Contractor is to determine the cofferdam size.
- The pay limits of “Cofferdam Excavation, Earth” and “Cofferdam Excavation, Rock” shall be 2 feet outside the perimeter of the footing.
- Use a 12 inch undercut, if determined necessary by the Resident Engineer.

If the constructed cofferdam is larger than the cofferdam excavation pay limits, provide payment for all unclassified channel excavation, including that portion which is inside the cofferdam but outside the cofferdam excavation pay limits, at the contract unit price for “Unclassified Channel Excavation”.

### 2.8.2 Material behind Abutment

The material behind abutments and retaining walls shall be as shown in Figure 2.8.1.1-1 and Figure 2.8.3.1-1 or in other project details.

### 2.8.3 Subbase Details

#### 2.8.3.1 Subbase Detail at Abutment

Figure 2.8.3.1-1 details the material placement behind the abutment.

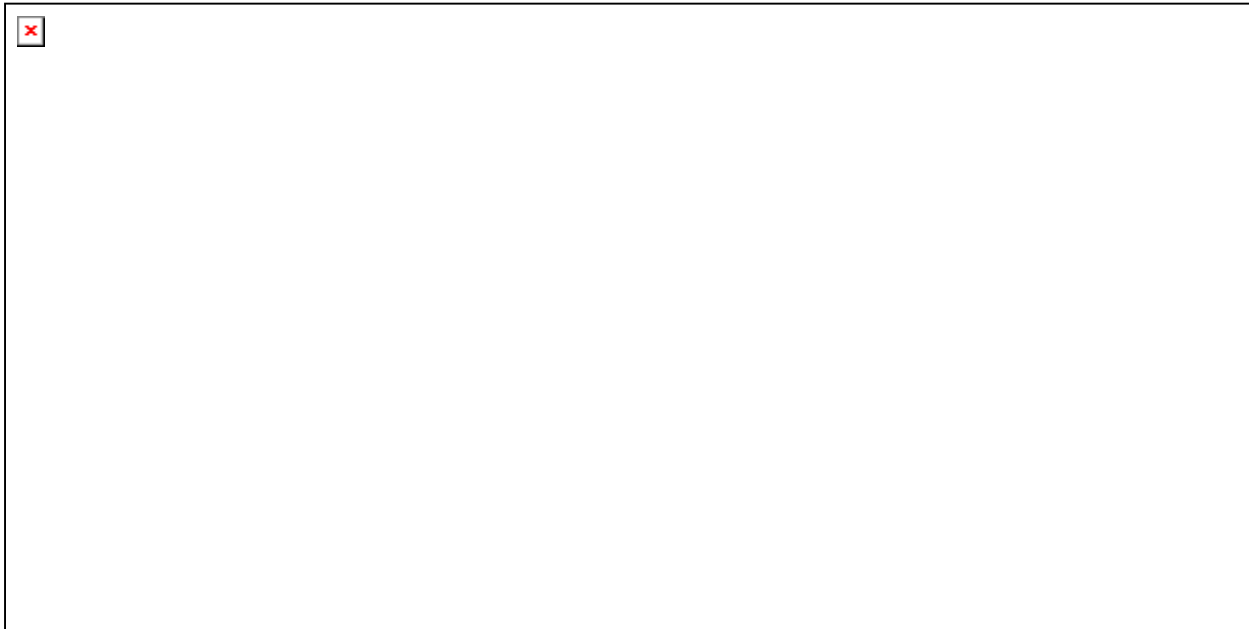

Figure 2.8.3.1-1 Subbase detail at abutment

### 2.8.3.2 Subbase at Begin and End of Project

Figure 2.8.3.2 -1 shows the placement of the materials at the beginning and end of project.

## 2.8.4 Typical Channel Section

Figure 2.8.4 -1 shows the typical quantities detail of the channel section.

- Continue stone fill to one foot below existing ground or one foot above design flow elevation, whichever is lower.
- Do not place grubbing materials on the stone fill directly under the bridge. Whenever channel slope intersects roadway subbase, grubbing material shall begin at the bottom of subbase.

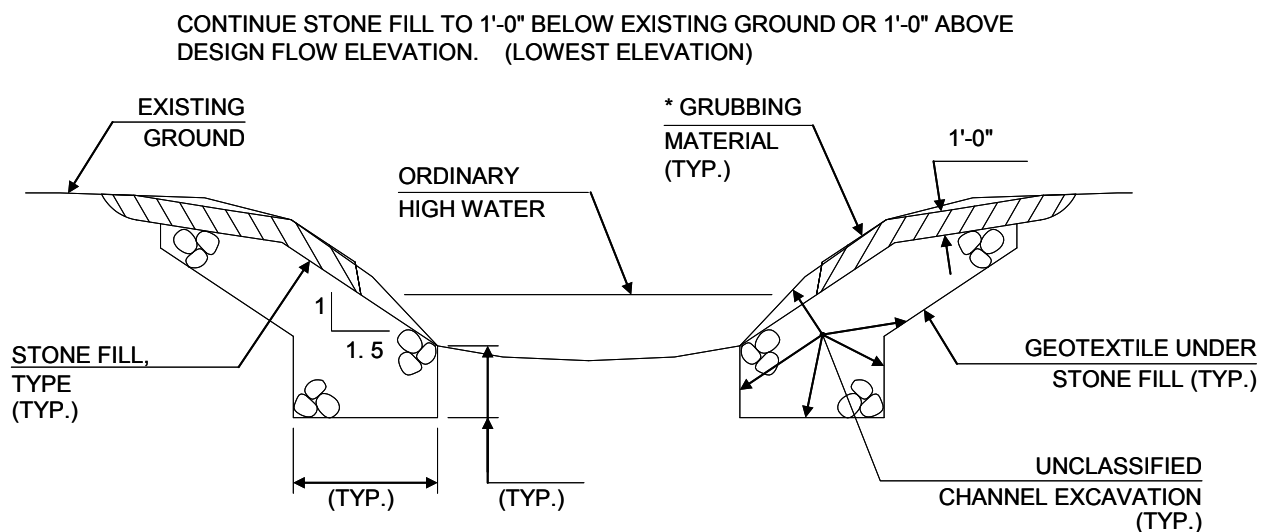

\* GRUBBING MATERIAL SHALL NOT BE PLACED ON THE STONE FILL IN THE AREA UNDER THE BRIDGE. WHENEVER CHANNEL SLOPE INTERSECTS ROADWAY SUBBASE, GRUBBING MATERIAL SHALL BEGIN AT THE BOTTOM OF SUBBASE.

Figure 2.8.4 -1 Channel Typical Section

## 2.9 Snow Fence

Any structure which has the snow plowed from it and passes over a traveled route shall have snow fence installed to prevent the plowed snow from encroaching on the route which passes below. A traveled route that should be protected by snow fence includes interstate, state and town roads, multi-use paths and railroad tracks.

## SECTION 3: LOADS AND LOAD FACTORS

### 3.1 GENERAL DESIGN

Refer to the AASHTO LRFD Bridge Design Specifications for more design information not included herein.

### 3.2 LOAD FACTORS AND COMBINATIONS

AASHTO calibrated the load factors and the combination of different load components presented in LRFD Table 3.4.1-1 to produce structures with more uniform reliability than that offered with Standard Specification designs.

Vermont generally uses all load combinations presented in the LRFD Specifications LRFD 3.4.1. Strength-II and Extreme Event-I load combinations however, are rarely considered. These limit states are used only for specialized structures or situations. See Figure 3.2 -1. The designer may ignore the AASHTO LRFD wind load on live load provisions when designing a covered bridge that has sufficient siding to shield the live load. In these cases, the designer shall use the wind load provisions found in the 2006 International Building Code to calculate wind load effects. Using the appropriate load paths, the designer shall transmit these load effects to the deck as service loads. In turn, factor these load effects according to AASHTO LRFD load combinations.

Table 3.2-1 Recommended Limit States for Bridge Types

Limit State	Bridge Type			
	Reinforced Concrete	Prestressed Concrete	Steel	Concrete Columns
STRENGTH I	X	X	X	X
STRENGTH II	O†	O†	O†	O†
STRENGTH III	O	O	X	O
STRENGTH IV	O	O	O	O
STRENGTH V	O	O	X	O
EXTREME EVENT I	O	O	O	O
EXTREME EVENT II	O	O	O	X
SERVICE I	X	X	X	X
SERVICE II			X	
SERVICE III		X		
SERVICE IV				X
FATIGUE	X	X	X	X

† Only when evaluating state defined trucks.

X – Required Default

O – Optional

- Strength I: Basic load combination used to determine the flexural and shear demands without wind.
- Strength II: Basic load combination used to determine the flexural and shear demands of a structure subject to a permit vehicle or a special design vehicle specified by the owner. (Vermont uses a special design vehicle in rare instances.)
- Strength III: Load combination used to determine flexural and shear demands that include wind. For covered bridge design, refer to Section 3.6 .
- Strength IV: Load combination relating to very high dead load to live load force effect ratios.
- Strength V: Load combination corresponding to normal vehicular use of the bridge concurrent with a wind of 55 mph.

- Extreme Event I: Load combination including earthquake effects. Generally, Vermont is in seismic zone 1 (LRFD 3.10.6). The designer need not consider earthquake load effects other than what is required in LRFD Section 3.10.9.2 for most projects. Some locations may have soil conditions where the designer may need to follow the requirements of seismic zone 2. For covered bridge design, refer to Section 3.8 in this manual.
- Extreme Event II: Load combination corresponding to ice loads, collision loads, and certain hydraulic events with a reduced vehicular live load. Use this combination for barrier and deck overhang designs.
- Service I: Load combination used for the design of most bridge elements. Use this combination for service load stress checks (prestressed concrete), deflection checks, crack control checks in reinforced concrete, etc.
- Service II: Load combination used to check yielding and connections in steel structures.
- Service III: Load combination used to check nominal tension in prestressed concrete structures.
- Fatigue I & II: Load combination used for the fatigue and fracture design of structures subject to repetitive live load. This pertains primarily to steel structures and steel reinforcement in concrete structures. Fatigue I is for infinite load-induced fatigue life. Fatigue II is for finite load-induced fatigue life.
- Construction: A special load case for structures where construction loads may exceed any of the above load cases while the bridge is under construction.

### 3.2.1 Covered Bridges

As recommended by the FHWA publication, Covered Bridge Manual, (FHWA-HRT-04-098 April 2005 Chapter 9) covered bridges should be designed according to the 2003 International Building Code (IBC) and the ASCE 7-02 Minimum Design Loads for Buildings and Structures in addition to the AASHTO LRFD specifications. This manual is updated to the 2006 IBC and ASCE 7-05 versions of these codes. All material relevant to a typical covered bridge is included in this section. Covered bridges that fall outside of the criteria presented in this section will require additional guidance from the mentioned specifications.

#### 3.2.1.1 Load Combinations for Buildings, Including Covered Bridges

When designing a covered bridge that has separate systems for the bridge housing and the deck, use the Load and Resistance Factor Design load combinations in Section 1605.2.1 of the 2006 IBC (See Table 3.2.1.1 -1 above) for the detached self-supported bridge housing. Live and dead loads acting on deck of these bridges shall follow the AASHTO LRFD Bridge Design Specifications as with any bridge deck.

Table 3.2.1.1 -1 Basic Load Combinations for Covered Bridge Housing

Load Combination	Loads
If DL/LL ratio > 8	DL – Dead
1.4DL	LL – Live
If DL/LL ratio < 8	Lr – Roof Live Load
1.2DL + 1.6LL + 0.5(Lr or S or R)	S – Snow
1.2DL + 1.6(Lr or S or R) + (f1L or 0.8W)	R – Rain
1.2DL + 1.6W + f1L + 0.5(Lr or S or R)	W – Wind
1.2DL + 1.0E + f1L + 0.2S	E – Earthquake
0.9DL + (1.0E or 1.6W)	

f1 = 1.0 for live loads over 100 lbs/ft<sup>2</sup>

f1 = 0.5 for all other live loads.

For situations when the covered bridge acts as a unit, design according to the following considerations:

- Design the runner boards, decking, floor beams, stringers, trusses and bearings with all dead load properly applied according to the AASHTO LRFD specifications with wind and seismic load effects determined using the IBC, applied as service loads and factored using the AASHTO LRFD load combinations.
- Design the roof and lateral and longitudinal support systems of the bridge housing according to the IBC.

### 3.2.2 Load Modifiers

Use the load modifier guidance in LRFD Section 1.3.2. For temporary bridges, use a load modifier of 0.90.

## 3.3 PERMANENT LOADS

### 3.3.1 Dead Loads (DL, DW and EV)

All loads are according to AASHTO Section 3 “Loads & Load Factors”, except as noted in Table 3.3.1 -1 in this manual. Concerning soil unit weight, Vermont soils tend to be rich in heavier materials than the average soil in the United States. Studies in the early 1970’s showed that the unit weight of Vermont soils tended to fluctuate around 0.135 kcf with the upper end nearing 0.140 kcf. The designer may multiply the soil unit weights listed in the AASHTO LRFD Bridge Design Specifications by 1.1 to obtain a more representative unit weight for Vermont Soils. The values in Table 3.3.1 -1 account for the higher aggregate unit weight.

Table 3.3.1 -1 Unit Weights<sup>1</sup>

Material	Unit Weight (k/ft <sup>3</sup> )
Bituminous Wearing Surfaces	0.150
Compacted Fill on Box Culverts	0.130
Reinforced Concrete Lightweight	0.115
Reinforced Concrete Sand-Lightweight	0.125
Reinforced Concrete Normal Weight with $f'_c \leq 5$ ksi	0.150
Reinforced Concrete Normal Weight with $5 \text{ ksi} < f'_c \leq 15 \text{ ksi}$	$0.145 + 0.001f'_c$

### 3.3.2 Design Pavement Thickness

Regardless of the actual pavement thickness detailed on the plans (see Section 2.7.2 ), use 2½ inches of pavement for the design of bare decks; this can be applied as either pavement or future pavement.

### 3.3.3 Bridge Rail

Refer to Section 13: for unit weights of rails used in Vermont.

---

<sup>1</sup> Using the unit weight values in the table may be useful in checking some design software. Using a unit weight of 0.150 k/ft<sup>3</sup> may be sufficient for most dead load requirements. A more accurately calculated unit weight may be necessary when calculating the concrete modulus of elasticity – especially for higher strength concrete mixes.

### 3.3.4 Earth Loads (EH, ES, LS and DD)

Refer to Section 3.9 for more information on earth load considerations.

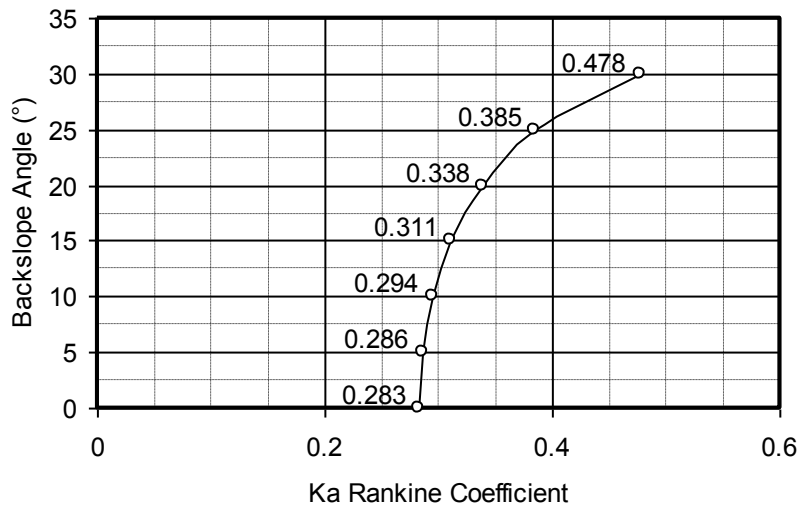

Figure 3.3.5 -1 Rankine Coefficient (Ka) to Back-Slope reference.

## 3.4 LIVE LOAD

### 3.4.1 Applying Live Load (LL)

The following conditions apply for live loads:

- For all Interstate, Primary, Secondary and Federal Secondary Routes and all Town Highway Routes on-system and off-system, design new structures for the controlling HL-93 live load as defined in the LRFD specifications.
- When evaluating a structure for load cases involving more than two lanes of traffic use a reduction factor or multiplier. This factor recognizes the reduced probability that all lanes will be fully loaded at the same time. Designers should note that the LRFD Specifications require using a factor of 1.2 for the design of structures carrying a single lane of traffic.
- Multiply the live load effects by the Dynamic Load Allowance (IM), which the Standard Specifications referred to as Impact. LRFD Table 3.6.2.1-1 provides the base dynamic load allowance factors. Designers should note the reduction of the values for buried components.
- Where appropriate consider additional live loads, which may include snow removal equipment on sidewalks and bridge inspection or snooper loads on bridges with large overhangs. If construction equipment or maintenance equipment can or will operate adjacent to retaining walls and abutments, a live load surcharge should be incorporated into the design.

### 3.4.2 Live Load on Buried or Earth Retaining Structures

For buried structures, apply a lane plus a design truck or tandem to the roadway and distribute through the fill. If the fill is 2 feet or less, apply the live load as a footprint to the top of the structure. For fills over 2 feet, the footprint load spreads out through the soil fill.

Design retaining walls and abutments with load combinations including live load surcharge. The equivalent soil heights to be used for different heights of abutments and retaining walls are provided in LRFD Tables 3.11.6.4-1 and 3.11.6.4-2.

### 3.4.3 Pedestrian Live Load

Unlike the Standard Specifications, AASHTO has not provided a reduction in sidewalk pedestrian live load intensity in the LRFD Specifications. The Standard Specs based the reduction on span length and sidewalk width.

Consider two loading cases when designing a conventional beam bridge with a sidewalk:

- Use a pedestrian live load on the sidewalk equal to 0.075 ksf and apply it in conjunction with a vehicular live load in the traffic lanes adjacent to the sidewalk.
- Place vehicular live load on the sidewalk and in adjacent traffic lanes with no pedestrian live load on the sidewalk.

For bridges carrying only pedestrian or bicycle traffic apply a live load of 0.085 k/ft<sup>2</sup> over the deck.

### 3.4.4 Centrifugal Force (CE)

Apply to bridges on horizontally curved alignments. The application of this force is similar to braking forces (see Section 3.4.5). Use multiple presence factors; however, do not use the dynamic load allowance.

### 3.4.5 Braking Force (BR)

Use judgment when applying braking forces to a structure. For two-lane, two-way bridges, apply traffic in one direction. For bridges with more than two lanes, apply braking force over half of width in one direction.

Do not apply the dynamic load allowance factor to braking forces; however, apply the multiple presence factors. Assume braking forces act at a height of 6 feet above the roadway surface and in a longitudinal direction. With elastomeric bearings, apply the force at the bearing.

### 3.4.6 Snow Removal Live Load

Consider snow removal for sidewalks on highway bridges or on pedestrian bridges. Table 3.4.6 -1 lists typical vehicles used for this task. The designer need not apply the pickup or mid-duty truck live load to bridges with widths less than 5 feet.

Table 3.4.6 -1 Typical Snow Removal Vehicles

Vehicle Description	Designation	Gross Vehicle Weight (kips)	Max Width (feet)	Wheel Base (feet)	Front Axle Load (kips)	Rear Axle Load (kips)	Min Bridge Rail to Rail Width (feet)
Skid Steer Figure 3.4.6 -1	HV-05-09	10	5	4	5	5	6
Pickup Truck	HV-10-09	20	6	14	6	14	10
Mid-Duty Truck*	HV-05-09	30	6	14	6	24	10

\* This truck is the H-15-44 truck from the AASHTO standard specifications.



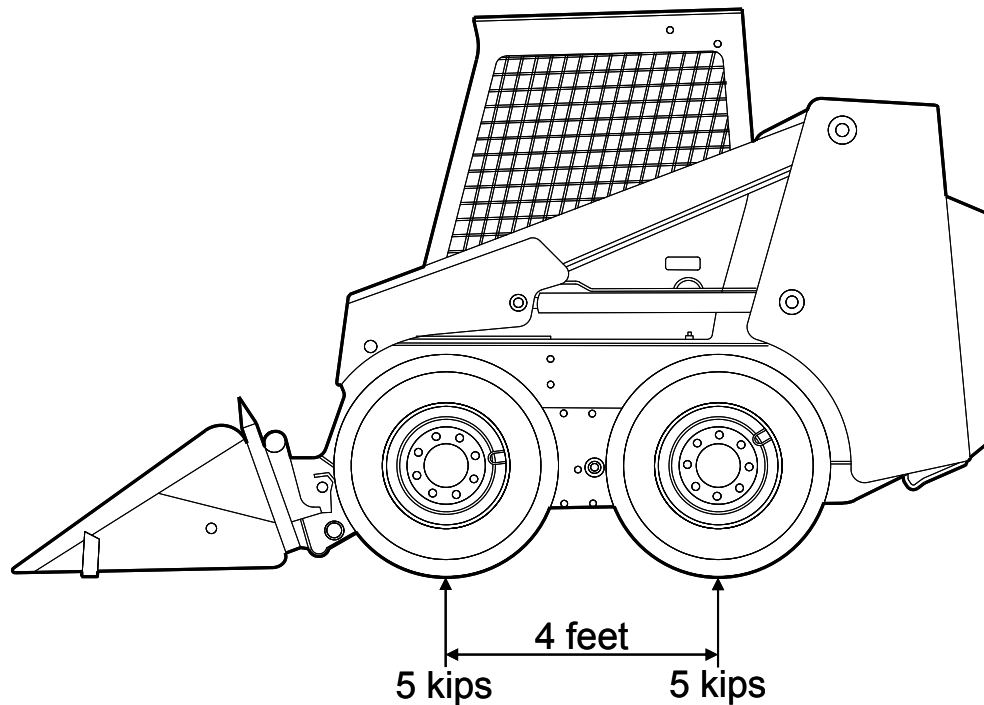

Figure 3.4.6 -1 Skid Steer Snow Removal Vehicle

## 3.5 WATER LOADS (WA)

### 3.5.1 Stream Flow Pressure

Evaluate stream flow pressure according to AASHTO 3.7.3 “Stream Pressure”.

- $\theta$  = angle between direction of flow and longitudinal axis of the pier. Design all piers for a minimum of  $\theta = 20^\circ$ .
- $V$  = design velocity of water for the design flood in strength and service limit states and for the check flood in the extreme event limit state.

The effective velocity shall be that calculated for the applicable  $Q$  for the condition under consideration.

## 3.6 WIND LOAD (WL AND WS)

### 3.6.1 Wind Load on Conventional Bridges

The basic design wind speed is 100 mph. The total height of most structures is below 30 feet therefore; use the base wind pressures for design. Check the vertical overturning wind load described in LRFD Article 3.8.2 for the design.

### 3.6.2 Wind Load on Live Load

Include the force effects of wind on live load for the Strength V and the Service I load combinations. LRFD Table 3.8.1.3-1 provides the force components (parallel and normal) for different wind skew angles. Apply wind load forces on live load at a height 6 feet above the top of the deck.

Applying wind loads to the live load is not necessary when designing an enclosed covered bridge (see Section 3.6.3.5). Investigate the amount of applied wind pressure on live load in partially enclosed covered bridges.

### 3.6.3 Wind Load on Buildings Including Covered Bridges

Design buildings including covered bridges using the 2006 International Building Code and the ASCE 7-05 Minimum Design Loads for Buildings and Other Structures.

Figure 3.6.3 -1 provides basic wind speed velocities for the State of Vermont. Towns shown within the Special Wind Region may have higher velocities. These areas will need further examination for unusual wind conditions. In considering wind load effects, an exposure category should be determined for each wind direction. Table 3.6.3 -1 offers general descriptions of the typical exposure categories for Vermont.

Table 3.6.3 -1 Exposure Category

Exposure	Description
B	Urban, suburban, wooded areas. (Usually assumed.)
C	Open terrain, flat open country, grasslands, shorelines
D	Flat, unobstructed, exposed to wind flowing over open water for at least a mile. (Bridge sites located near Lake Champlain where it is possible for winds to flow over the lake for at least a mile.)

(2006 IBC 1609.4)

#### 3.6.3.1 Wind Speed Conversion

The values shown in Figure 3.6.3 -1 represent the basic wind speed in a sustained 3-second gust. Use Table 3.6.3.1 -1 to convert the basic wind speed to the fastest-mile wind velocity.

The values in the table are based on the following equation (IBC 2006 equation 16-34):

$$V_{fm} = (V_{3S} - 10.5)/1.05 \quad (3.6.3.1 -1)$$

Table 3.6.3.1 -1 Wind Speed Conversion mph (m/s)

$V_{3S}$	90	100	105	110
$V_{fm}$	76	85	90	95

Use linear interpolation

$V_{3S}$  is the 3 second gust wind speed (Figure 3.6.3 -1)

$V_{fm}$  is the fastest mile wind speed.

(2006 IBC 1609.3.1)

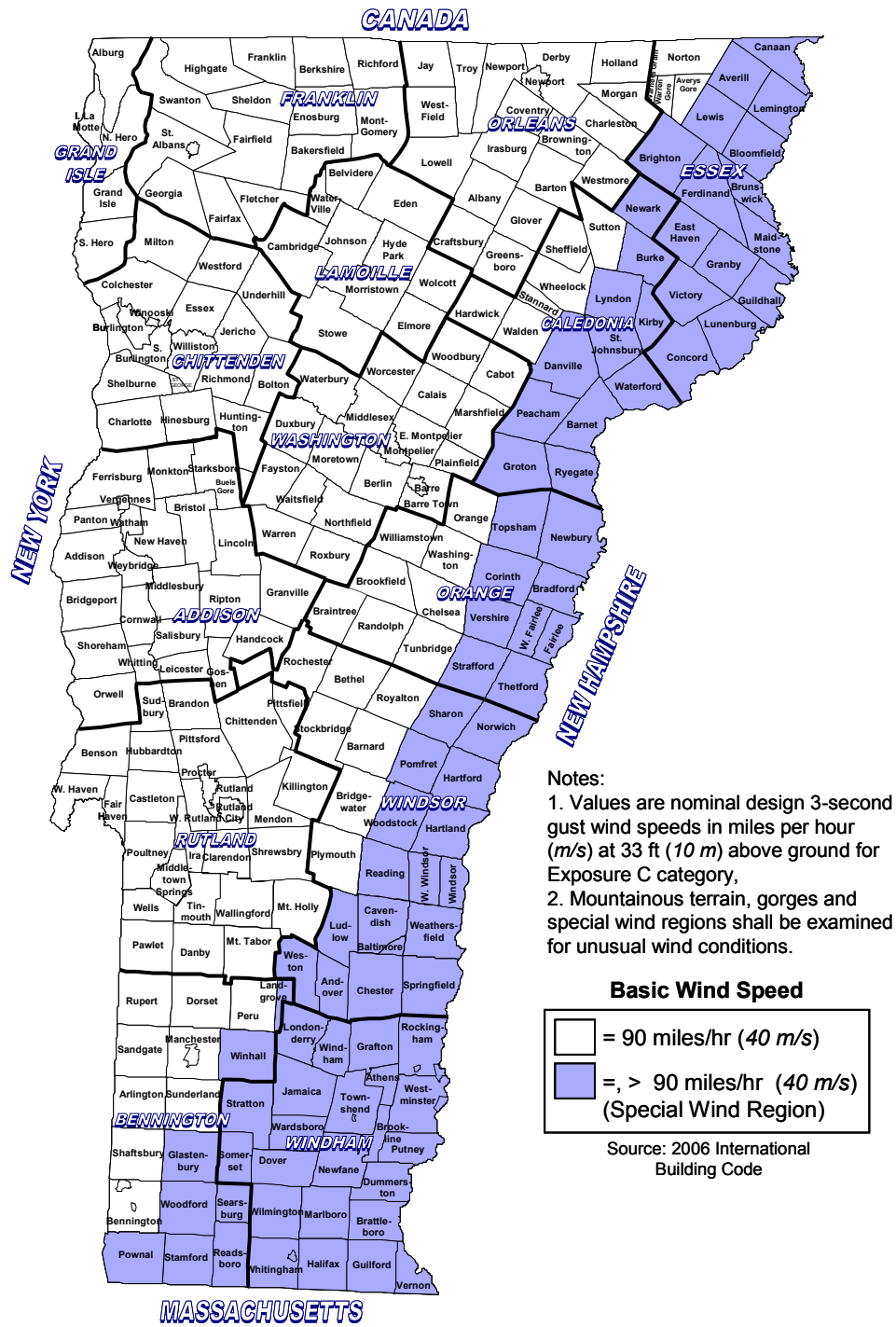

Figure 3.6.3 -1 Vermont Basic Wind Speed (3-Second Gust) (2006 International Building Code)

### 3.6.3.2 Importance Factor for Wind Loads

For bridge classifications, refer to Section 3.8.3.5. The importance factor will be (ASCE 7-05 Table 6-1):

- 1.00 for non-essential covered bridges. Most covered bridges will fall under this category.

- 1.15 for essential covered bridges. This case would be rare. In some remote locations, the covered bridge in this classification may be the only way to access a small community.

### 3.6.3.3 Minimum Wind Load on Covered Bridges

The minimum wind pressure shall be 10 lbs/ft<sup>2</sup> on: (ASCE 7-05 6.1.4.1)

- The main-force-resisting system, applied to the projected area of the covered bridge normal to the direction of the wind. Use this pressure in calculating gross forces to determine overall stability of the covered bridge in sliding, uplift and overturning.
- The siding and roofing of the covered bridge (components and cladding). This pressure is the minimum algebraic difference for each direction of the surface acting normal to that surface. Apply pressures on both sides of the surface. In this case, the siding must be able to withstand at least a 10 lbs/ft<sup>2</sup> pressure pushing on the wall and pulling the wall off.
- An area of an open building and other structures (a building with each wall 80% or more open) either normal to the wind direction or projected on a plane normal to the wind direction. A covered bridge with no siding may be considered an open building if the projected area of the openings (where wind may pass through) is at least 80% of the entire projected area. The wind pressure shall be applied to the projected area of the roof and frame or truss (Af).

### 3.6.3.4 Anchorage

Anchor each component of the covered bridge sufficiently to provide a continuous load path to the bridge deck or abutments. These anchorages must resist wind-induced overturning, uplift and sliding. (2006 IBC 1604.9)

### 3.6.3.5 Covered Bridge Types

Use this section to determine if the covered bridge in question falls outside the criteria for a typical covered bridge. Most covered bridges in Vermont are enclosed structures. However, some bridges may have different openings at each end or may have a more open truss system. The equations below will aid in determining if the covered bridge will need special design considerations.

#### 3.6.3.5.1 Open Covered Bridge

Each wall of an open covered bridge is at least 80% open. (ASCE 7-05 6.2)

$$A_o \geq 0.8A_g \quad (3.6.3.5.1 -1)$$

$A_o$  = area of openings on the wall surface resisting positive wind pressure.

$A_g$  = gross area of the wall where  $A_o$  is identified.

#### 3.6.3.5.2 Partially Enclosed Covered Bridge

A partially enclosed covered bridge must meet both of the following criteria: (ASCE 7-05 6.2)

- The total area of openings in the wall resisting positive wind pressure must exceed the total area of the remaining openings of the covered bridge by more than 10%.

$$A_o > 1.10A_{oi} \quad (3.6.3.5.2 -1)$$

and

- The total area of openings in the wall resisting positive wind pressure must be greater than the lesser of:

$$4 \text{ ft}^2 \quad (3.6.3.5.2 -2)$$

$$A_o > 4 \text{ ft}^2 (A_o > ), \quad (3.6.3.5.2 -3)$$

- or 1% of the area of the wall,

$$A_o > 0.01A_g \quad (3.6.3.5.2 -4)$$

- With the remaining areas of the openings in the covered bridge not exceeding 20% the total area of the walls not including  $A_g$ .

$$A_{oi}/A_{gi} \leq 0.20 \quad (3.6.3.5.2 -5)$$

$A_{oi}$  = total area of openings in the entire covered bridge (roof and walls) excluding  $A_o$  as defined in Section 3.6.3.5.1 .

$A_{gi}$  = total surface area of covered bridge (roof and walls) excluding  $A_g$  as defined in Section 3.6.3.5.1.

Because each side and each end of most covered bridges is identical to its opposite,  $A_o$  will always equal  $A_{oi}$ . Therefore, classifying covered bridges as partially enclosed is unlikely.

### 3.6.3.5.3 Enclosed Covered Bridge

An enclosed covered bridge is a bridge that does not meet the criteria for either Open Covered Bridge or a Partially Enclosed Covered Bridge. Typically, covered bridges will qualify as an enclosed covered bridge. (ASCE 7-05 6.2)

## 3.6.3.6 Determining Wind Load for Covered Bridges

### 3.6.3.6.1 Main Wind Force Resisting System (MWFRS)

Treat the entire bridge as a single force resisting system. See Section 0 to design the roof and siding. (ASCE 7-05 6.4.2)

To use this section, the covered bridge must be a typical enclosed covered bridges (see Section 3.6.3.5 ) with a roof pitch equal to or less than 12 on 12 . The width of the bridge must exceed its mean roof height ( $h$ ). Designs not complying with these conditions will require additional design considerations from the 2006 IBC or the ASCE 7-05.

- Basic Wind Speed ( $V$ ): Determine  $V$  in accordance with Section 3.6.3 .
- Importance Factor ( $IW$ ): Determine  $IW$  in accordance with Section 3.6.3.2 .
- Exposure Category: Determine the exposure category in accordance with Section 3.6.3 . For exposure C, the obtain  $K_{zt}$  from Table 3.6.3.6.1 -1. All other exposure categories,  $K_{zt}$  equals 1.0. Surface wind speeds tend to rise dramatically over ridges or on the leading edge of an escarpment (see Figure 3.6.3.6.1 -1).
- Height and Exposure Adjustment Coefficient ( $\lambda$ ): Obtain  $\lambda$  from Table 3.6.3.6.1 -2. Use the mean roof height [ (ridge height + eave height) / 2 ] to obtain  $\lambda$ .
- Obtain the simplified design wind pressure ( $ps_{30}$ ) for the Main Wind Force Resisting System (MWFRS) from Table 3.6.3.6.1 -4for each zone (A through H) as shown in Figure 3.6.3.6.1 -2 and Figure 3.6.3.6.1 -3 as it applies to the covered bridge design.
  - The tabulated values for horizontal pressures ( $ps_{30}$ ) (Zones A, B, C and D) represent the net pressure from both windward and leeward pressures.
  - Use Table 3.6.3.6.1 -3 to get roof slope angle from designed roof pitch in 12”.
  - For roof slopes above 25°, both the positive internal pressure case (Load Case 1) and the negative internal pressure case (Load Case 2) must be checked.
  - Use the columns for EOH and GOH in Table 3.6.3.6.1 -4 for pressures on overhangs if Zones E or G (windward edge) extends out to an overhang.
- Adjust the obtained pressures using the following equation:

- $ps = \lambda KztIW ps30$  (3.6.3.6.1 -1)
- Assume the minimum horizontal pressure on the covered bridge (sum of Zones A, B, C and D) is at least +10 psf and the vertical pressure on the covered bridge (sum of Zones E, F, G and H) is 0 psf.
- Use this data to calculate the bridge housing stability and shear at the housing connection to the bridge deck or at the housing's bearings in both longitudinal and transverse directions.

Table 3.6.3.6.1 -1 Topographic Factor,  $Kzt^2$

H	Ridge	Escarpment	H	Ridge	Escarpment	H	Ridge	Escarpment
≤8'		1.00	14'		1.08	20'		1.17
9'		1.02	15'		1.10	21'		1.19
10'		1.03	16'		1.12	22'		1.20
11'		1.04	17'		1.13	23'		1.21
12'		1.05	18'	1.15	1.14	24'		1.23
13'		1.07	19'	1.17	1.16	25'		1.24

Table 3.6.3.6.1 -2 Adjustment Factor for Covered Bridge Height and Exposure ( $\lambda$ )

Mean Roof Height (feet)	Exposure		
	B	C	D
15	1.00	1.21	1.47
20	1.00	1.29	1.55
25	1.00	1.35	1.61
30	1.00	1.40	1.66
35	1.05	1.45	1.70

(ASCE 7-05 Figure 6-2)

Table 3.6.3.6.1 -3 Slope Conversion

Ris in one foot	Slope
1:12	5°
2:12	9°
3:12	14°
4:12	18°
5:12	23°
6:12	27°
7:12	30°
8:12	34°
9:12	37°
10:12	40°
11:12	43°
12:12	45°

<sup>2</sup> The table's basis is ASCE 7-05 Figure 6-4. This table assumes a roadway width of 20 feet on a longitudinal ridge or aligning the edge of an escarpment.  $Kzt$  varies slightly in a 10'± from this width.

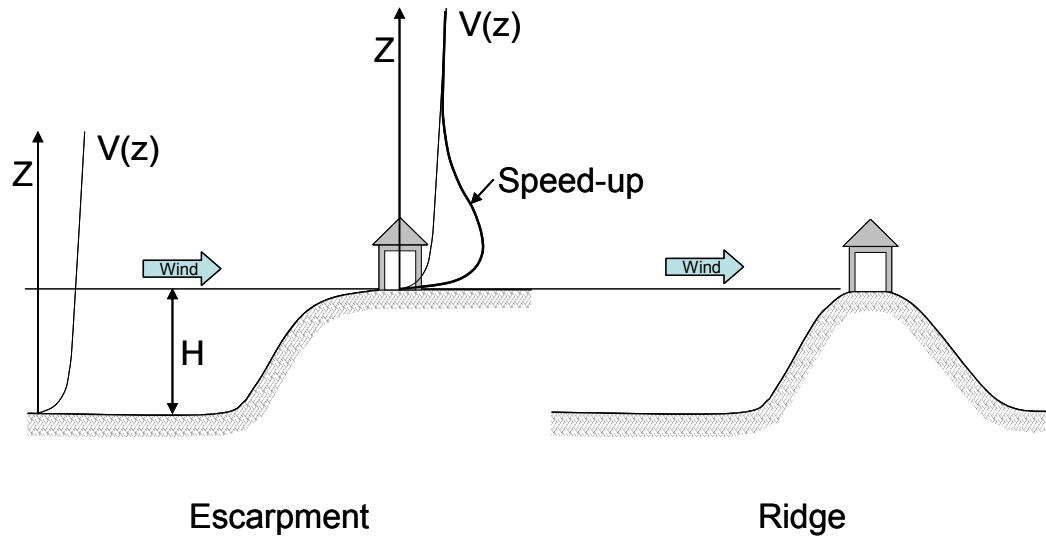

Figure 3.6.3.6.1 -1 Main Wind Force Resisting System (MWFRS) in Transverse

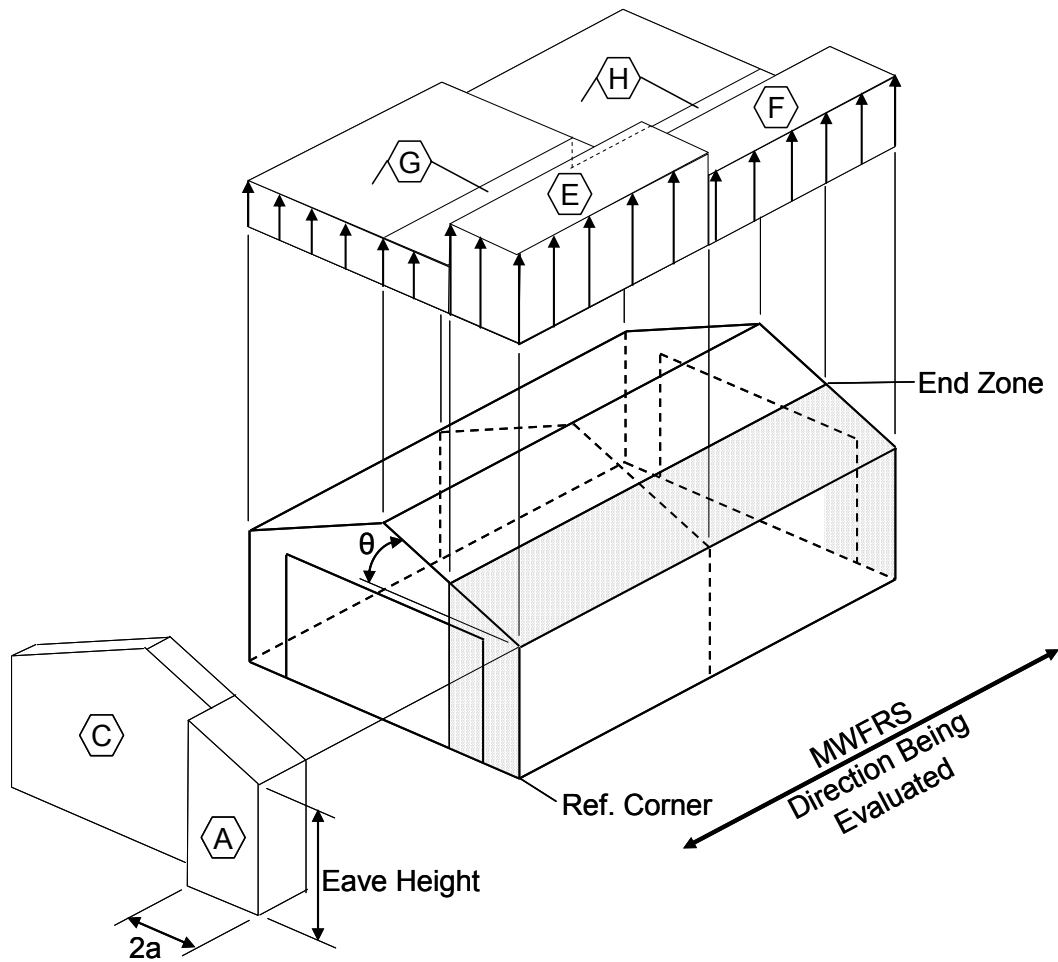

Figure 3.6.3.6.1 -2 Main Wind Force Resisting System (MWFRS) in Transverse Direction (Source: ASCE 7-05 Figure 6-2)

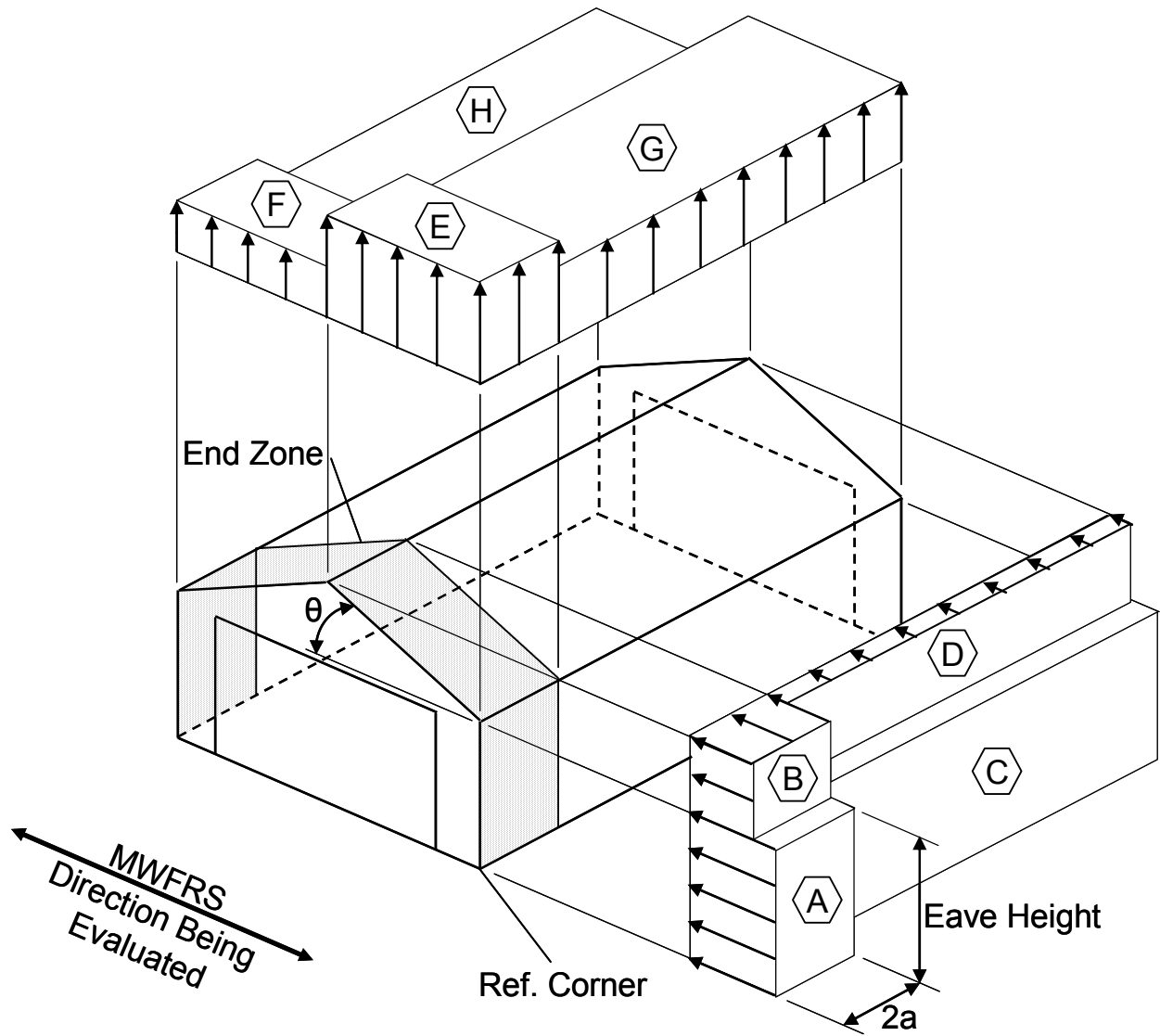

Figure 3.6.3.6.1 -3 Main Wind Force Resisting System (MWFRS) in Longitudinal Direction (Source: ASCE 7-05 Figure 6-2)



Table 3.6.3.6.1 -4 Simplified Design Wind Pressure (Main Windforce-Resisting System), ps30 (Exposure B at h=30ft with Kzt=1.0 and Iw=1.0) (psf)

Basic Wind Speed (mph)	Roof Angle	Roof Rise in 12"	Load Case	Zones									
				Horizontal Pressure				Vertical Pressure				Overhangs	
				A	B	C	D	E	F	G	H	E <sub>OH</sub>	G <sub>OH</sub>
90	0 to 5°	Flat	1	12.8	-6.7	8.5	-4.0	-15.4	-8.8	-10.7	-6.8	-21.6	-16.9
	10°	2	1	14.5	-6.0	9.6	-3.5	-15.4	-9.4	-10.7	-7.2	-21.6	-16.9
	15°	3	1	16.1	-5.4	10.7	-3.0	-15.4	-10.1	-10.7	-7.7	-21.6	-16.9
	20°	4	1	17.8	-4.7	11.9	-2.6	-15.4	-10.7	-10.7	-8.1	-21.6	-16.9
	25°	6	1	16.1	2.6	11.7	2.7	-7.2	-9.8	-5.2	-7.8	-13.3	-11.4
			2	--	--	--	--	-2.7	-5.3	-0.7	-3.4	--	--
	30° to 45°	7 to 12	1	14.4	9.9	11.5	7.9	1.1	-8.8	0.4	-7.5	-5.1	-5.8
			2	14.4	9.9	11.5	7.9	5.6	-4.3	4.8	-3.1	-5.1	-5.8
100	0 to 5°	Flat	1	15.9	-8.2	10.5	-4.9	-19.1	-10.8	-13.3	-8.4	-26.7	-20.9
	10°	2	1	17.9	-7.4	11.9	-4.3	-19.1	-11.6	-13.3	-8.9	-26.7	-20.9
	15°	3	1	19.9	-6.6	13.3	-3.8	-19.1	-12.4	-13.3	-9.5	-26.7	-20.9
	20°	4	1	22.0	-5.8	14.6	-3.2	-19.1	-13.3	-13.3	-10.1	-26.7	-20.9
	25°	6	1	19.9	3.2	14.4	3.3	-8.8	-12.0	-6.4	-9.7	-16.5	-14.0
			2	--	--	--	--	-3.4	-6.6	-0.9	-4.2	--	--
	30° to 45°	7 to 12	1	17.8	12.2	14.2	9.8	1.4	-10.8	0.5	-9.3	-6.3	-7.2
			2	17.8	12.2	14.2	9.8	6.9	-5.3	5.9	-3.8	-6.3	-7.2
110	0 to 5°	Flat	1	19.2	-10.0	12.7	-5.9	-23.1	-13.1	-16.0	-10.1	-32.3	-25.3
	10°	2	1	21.6	-9.0	14.4	-5.2	-23.1	-14.1	-16.0	-10.8	-32.3	-25.3
	15°	3	1	24.1	-8.0	16.0	-4.6	-23.1	-15.1	-16.0	-11.5	-32.3	-25.3
	20°	4	1	26.6	-7.0	17.7	-3.9	-23.1	-16.0	-16.0	-12.2	-32.3	-25.3
	25°	6	1	24.1	3.9	17.4	4.0	-10.7	-14.6	-7.7	-11.7	-19.9	-17.0
			2	--	--	--	--	-4.1	-7.9	-1.1	-5.1	--	--
	30° to 45°	7 to 12	1	21.6	14.8	17.2	11.8	1.7	-13.1	0.6	-11.3	-7.6	-8.7
			2	21.6	14.8	17.2	11.8	8.3	-6.5	7.2	-4.6	-7.6	-8.7

For SI: 1" = 25.4 mm, 1' = 304.8 mm, 1° = 0.0174 rad, 1 mph = 0.44 m/s, 1 psf = 47.9 N/m<sup>2</sup>.

Negative pressures in the table point away from the design surface where positive pressures point toward the design surface.

(ASCE 7-05 Figure 6-2)

### 3.6.3.6.2 Components and Cladding

This section applies to covered bridges that meet the same criteria as Section 3.6.3.6.1. The process for components and cladding is similar, however the pressures are applied normal to the surfaces shown in Figure 3.6.3.6.2 -1. Do not apply these pressures to the entire bridge, these pressures are applied to each component of the bridge (i.e. sheathing for the roof and walls) Pressures (pnet30) can be obtained from Table 3.6.3.6.3 -1 or on overhangs, Table 3.6.3.6.3 -2. Using  $\lambda$  and IW from Section 3.6.3.6.1, adjust pnet30 with the following equation:

$$p_{net} = \lambda IW p_{net30} \quad (3.6.3.6.2 -1)$$

$p_{net} \geq +10$  psf for positive pressures, and

$p_{net} \leq -10$  psf (in the negative direction) for negative pressures.

In Figure 3.6.3.6.2 -1, the value of 'a' is the lesser of:

- 10 percent of the width of the covered bridge
- the greater of:
  - 40 percent of the mean roof height (0.40h),
  - 4 percent of the covered bridge width or
  - 3 feet.

The mean roof height (h) may equal the eave height for roof angles less than 10°.

### **3.6.3.6.3 Area to Load for Cladding and Components**

The following effective area is used in Table 3.6.3.6.3 -1 and Table 3.6.3.6.3 -2: (ASCE 7-05 6.2)

$$A_e = l * b_e \quad (3.6.3.6.3 -1)$$

where,

$l$  = Span Length.

$b_e$  = effective tributary width. This is the greater of the spacing between joists or studding or one-third the span length.

The effective area required for cladding fasteners ( $A_{ef}$ ) need not exceed that required for an individual faster.

$$A_{ef} = A_e / n \quad (3.6.3.6.3 -1)$$

where,

$n$  = number of fasteners used.

## **3.6.4 Wind Load on Signs**

Use the latest edition of the AASHTO Standard Specifications for Structural Supports for Highway Signs, Luminaires, and Traffic Signals with all subsequent interims for the design of sign structures.

### **3.6.4.1 Reserved Capacity**

Design sign structures with reserved capacity to allow for future addition of signs or signals. All applied load to design capacity ratios should be equal to or less than 80%.

### **3.6.4.2 Fatigue Design Checks**

Designs need not include checking galloping fatigue, as this is not a concern for Vermont. Nearly all of Vermont's sign and signal masts are circular in section. Galloping does not affect circular sections<sup>3</sup>. All new posts shall have a taper of 0.14 inch/foot or greater to eliminate vortex shedding effects. Designs need not include checking vortex shedding fatigue for posts that have a taper of 0.14 inch/foot or greater.

---

<sup>3</sup> Ocel, Justin M. et al., "Fatigue-Resistant Design for Overhead Signs, Mast-Arm Signal Poles, and Lighting Standards", University of Minnesota, Department of Civil Engineering p. 17

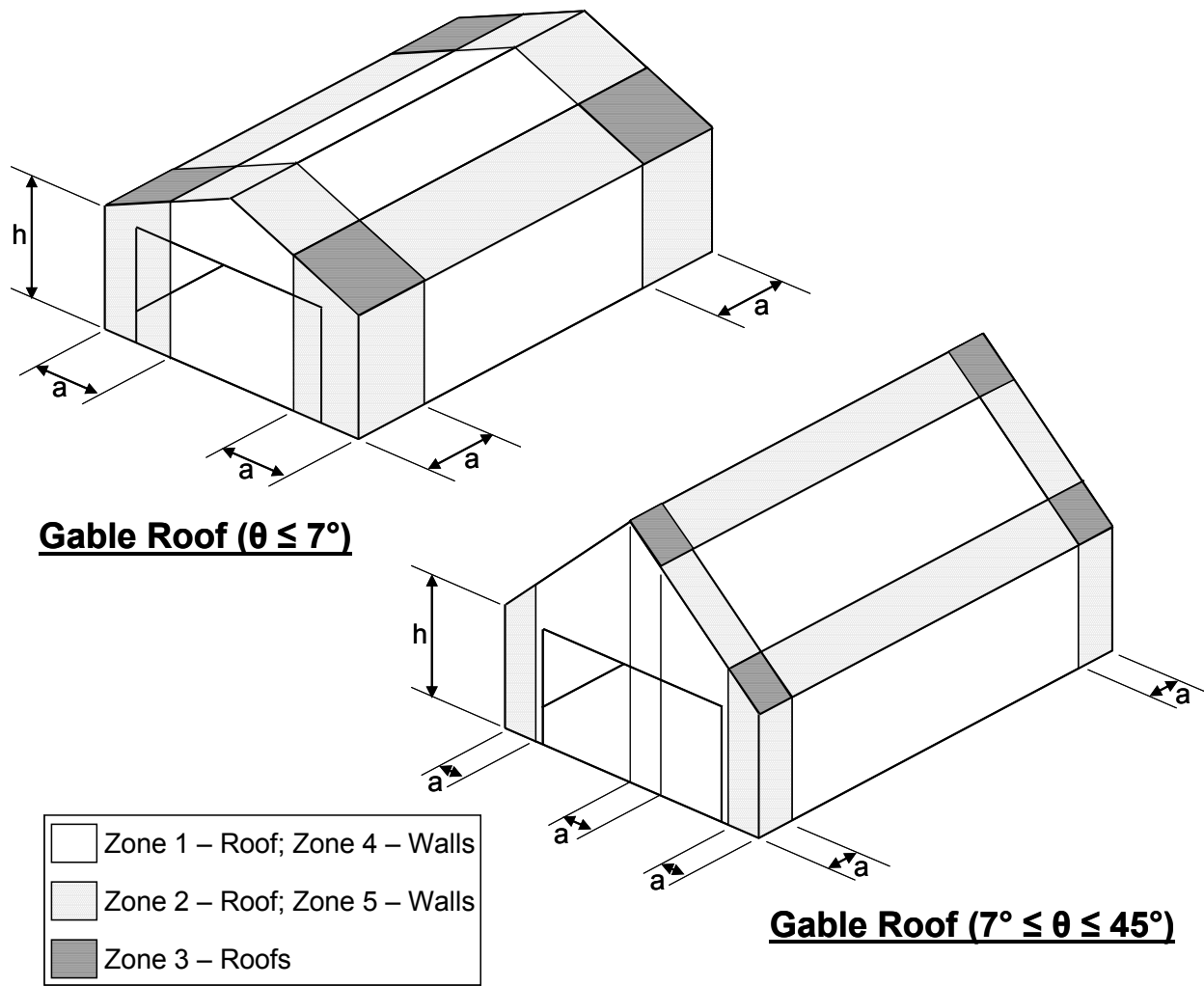

Figure 3.6.3.6.2 -1 Components and Cladding Pressure (Source: ASCE 7-05 Figure 6-3)

Table 3.6.3.6.3 -1 Net design wind pressure (Component and Cladding), pnet30 (Exposure B at h=30 ft with IW=1.0) (psf)

	Zone	Effective Wind Area	Basic Wind Speed V (mph – 3 second gust)					
			90		100		110	
Roof 0° to 7°	1	10	5.9	-14.6	7.3	-18.0	8.9	-21.8
	1	20	5.6	-14.2	6.9	-17.5	8.3	-21.2
	1	50	5.1	-13.7	6.3	-16.9	7.6	-20.5
	1	100	4.7	-13.3	5.8	-16.5	7.0	-19.9
	2	10	5.9	-24.4	7.3	-30.2	8.9	-36.5
	2	20	5.6	-21.8	6.9	-27.0	8.3	-32.6
	2	50	5.1	-18.4	6.3	-22.7	7.6	-27.5
	2	100	4.7	-15.8	5.8	-19.5	7.0	-23.6
	3	10	5.9	-39.8	7.3	-45.4	8.9	-55.0
	3	20	5.6	-30.5	6.9	-37.6	8.3	-45.5
	3	50	5.1	-22.1	6.3	-27.3	7.6	-33.1
	3	100	4.7	-15.8	5.8	-19.5	7.0	-23.6
Roof > 7° to 27°	1	10	8.4	-13.3	10.4	-16.5	12.5	-19.9
	1	20	7.7	-13.0	9.4	-16.0	11.4	-19.4
	1	50	6.7	-12.5	8.2	-15.4	10.0	-18.6
	1	100	5.9	-12.1	7.3	-14.9	8.9	-18.1
	2	10	8.4	-23.2	10.4	-28.7	12.5	-34.7
	2	20	7.7	-21.4	9.4	-26.4	11.4	-31.9
	2	50	6.7	-18.9	8.2	-23.3	10.0	-28.2
	2	100	5.9	-17.0	7.3	-21.0	8.9	-25.5
	3	10	8.4	-34.3	10.4	-42.4	12.5	-51.3
	3	20	7.7	-32.1	9.4	-39.6	11.4	-47.9
	3	50	6.7	-29.1	8.2	-36.0	10.0	-43.5
	3	100	5.9	-26.9	7.3	-33.2	8.9	-40.2
Roof > 27° to 45°	1	10	13.3	-14.6	16.5	-18.0	19.9	-21.8
	1	20	13.0	-13.8	16.0	-17.1	19.4	-20.7
	1	50	12.5	-12.8	15.4	-15.9	18.6	-19.2
	1	100	12.1	-12.1	14.9	-14.9	18.1	-18.1
	2	10	13.3	-17.0	16.5	-21.0	19.9	-25.5
	2	20	13.0	-16.3	16.0	-20.1	19.4	-24.3
	2	50	12.5	-15.3	15.4	-18.9	18.6	-22.9
	2	100	12.1	-14.6	14.9	-18.0	18.1	-21.8
	3	10	13.3	-17.0	16.5	-21.0	19.9	-25.5
	3	20	13.0	-16.3	16.0	-20.1	19.4	-24.3
	3	50	12.5	-15.3	15.4	-18.9	18.6	-22.9
	3	100	12.1	-14.6	14.9	-18.0	18.1	-21.8
Wall	4	10	14.6	-15.8	18.0	-19.5	21.8	-23.6
	4	20	13.9	-15.1	17.2	-18.7	20.8	-22.6
	4	50	13.0	-14.3	16.1	-17.6	19.5	-21.3
	4	100	12.4	-13.6	15.3	-16.8	18.5	-20.4
	4	500	10.9	-12.1	13.4	-14.9	16.2	-18.1
	5	10	14.6	-19.5	18.0	-24.1	21.8	-29.1
	5	20	13.9	-18.2	17.2	-22.5	20.8	-27.2
	5	50	13.0	-16.5	16.1	-20.3	19.5	-24.6
	5	100	12.4	-15.1	15.3	-18.7	18.5	-22.6
	5	500	10.9	-12.1	13.4	-14.9	16.2	-18.1

For SI: 1'' = , 1' = , 1° = 0.0174 rad, 1 mph = , 1 psf = .

Negative pressures in the table point away from the design surface where positive pressures point toward the design surface.

(ASCE 7-05 Figure 6-3)

Table 3.6.3.6.3 -2 Roof Overhang Net Design Wind Pressure (Component and Cladding), pnet30 (Exposure B at h=30 ft with IW=1.0) (psf) (ASCE 7-05 Figure 6-3)

	Zone	Effective Wind Area	Basic Wind Speed V (mph – 3 second gust)		
			90	100	110
Roof 0° to 7°	2	10	-21.0	-25.9	-31.4
	2	20	-20.6	-25.5	-30.8
	2	50	-20.1	-24.9	-30.1
	2	100	-19.8	-24.4	-29.5
	3	10	-34.6	-42.7	-51.6
	3	20	-27.1	-33.5	-40.5
	3	50	-17.3	-21.4	-25.9
	3	100	-10.0	-12.2	-14.8
Roof 7° to 27°	2	10	-27.2	-33.5	-40.6
	2	20	-27.2	-33.5	-40.6
	2	50	-27.2	-33.5	-40.6
	2	100	-27.2	-33.5	-40.6
	3	10	-45.7	-56.4	-68.3
	3	20	-41.2	-50.9	-61.6
	3	50	-35.3	-43.6	-52.8
	3	100	-30.9	-38.1	-46.1
Roof 27° to 45°	2	10	-24.7	-30.5	-36.9
	2	20	-24.0	-29.6	-35.8
	2	50	-23.0	-28.4	-34.3
	2	100	-22.2	-27.4	-33.2
	3	10	-24.7	-30.5	-36.9
	3	20	-24.0	-29.6	-35.8
	3	50	-23.0	-28.4	-34.3
	3	100	-22.2	-27.4	-33.2

## 3.7 ICE LOAD (IC)

### 3.7.1 Ice Pressure

Follow the provisions of AASHTO 3.9 “Ice Loads”, using the following:

- A semicircular pier nose with some inclination is the preferred shape.
- Consult the Hydraulics Unit concerning ice thickness, stream conditions, and pier shape and loads.
  - In the absence of elevation information, apply ice forces at the elevation of a Q-10 discharge.
- Extreme Event Ice loads need not be considered concurrently with Service or Extreme Event scour conditions.

### 3.7.2 Snow Loads

Figure 3.7.2 -1 provides ground snow loads in the State of Vermont for the determination of design snow loads for bridge decks and roofs. Ignore this section for bridges designed for the LRFD HL-93 live load, unless the bridge is a covered bridge or bridges located on roadways the Agency closes during the winter months.

#### 3.7.2.1 Snow Load on Bridge Decks

According to LRFD section 3.9.6 including the commentary, designs need not include snow load for bridge decks unless an avalanche causes the snow load or if the snowfall accumulation creates a load of 70 lb/ft<sup>2</sup> or more. Many

towns in the Green Mountain Range have snow loads of 70 lb/ft<sup>2</sup> (see Figure 3.7.2 -1). For these towns, consider snow loads in the Extreme Event II load combination on bridge.

### 3.7.2.2 Snow Load on Buildings including Covered Bridges

Design buildings, including covered bridges using Section 1608 of the 2006 International Building Code and Section 7 of the ASCE 7-05 Minimum Design Loads for Buildings and Other Structures.

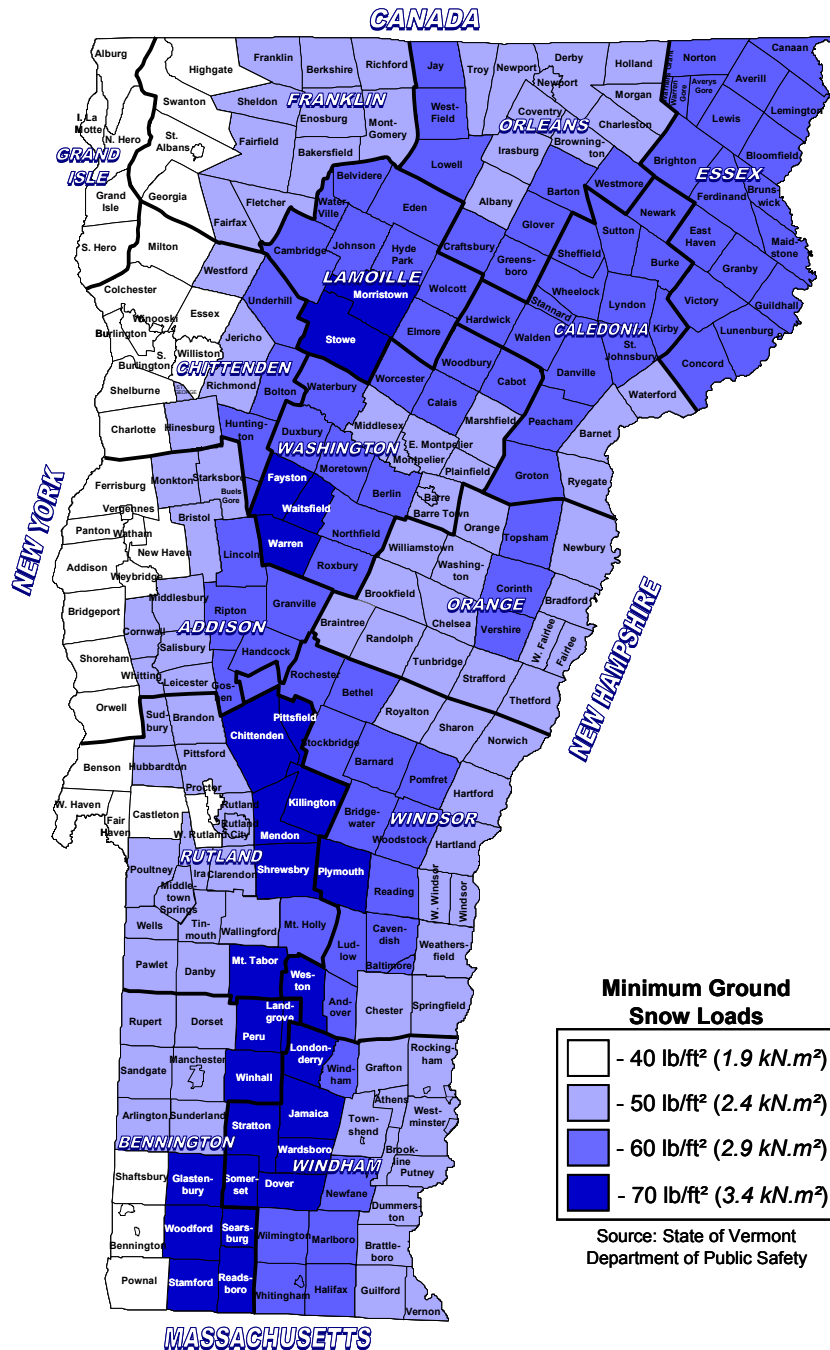

Figure 3.7.2 -1 Minimum Ground Snow Loads (The Vermont Department of Public Safety)

Project elevations above the average for the town in question, may require an increase in snow loads. Contact local building official or SEAVT. (Structural Engineers Assoc. of VT)

### 3.7.2.2.1 Snow Loads on Covered Bridges

This section assumes the roof slope of covered bridges exceeds 1 on 12 (5°). Typical covered bridge roofs are gable shaped with slopes equaled to or greater than 8 on 12 (34°). Design sloped roofs according to section 7.4 of the ASCE 7-05. For an attached roof segment, such as a roof over a pedestrian walkway, design according to section 7.7 of the ASCE 7-05. Roof slopes equaled to or under 1 on 12 (5°) are considered flat and shall be designed according to section 7.3 of the ASCE 7-05. Apply the snow load as a horizontal projection on the sloping surface.

Calculate the snow load for a single gable roof using:

$$pS = 0.7CSCeCtISpg \quad (3.7.2.2.1 -1)$$

where

$$pS \geq 20(IS) / CS \text{ (lbs/ft}^2, \text{ kN/m}^2\text{)} \quad (3.7.2.2.1 -2)$$

CS = Roof Slope Factor from Figure 3.7.2.2.1 -1.

Ce = Exposure Factor from Table 3.7.2.2.1 -1.

Ct = 1.2 (Thermal Factor) for covered bridges (cold roof)

IS = Importance Factor.

Table 3.7.2.2.1 -1 Exposure Factor, Ce

Terrain Category	Exposure of Roof		
	Fully Exposed	Partially Exposed	Sheltered
B	0.9	1	1.2
C	0.9	1	1.1
D	0.8	0.9	1

(ASCE 7-05 Table 7-2)

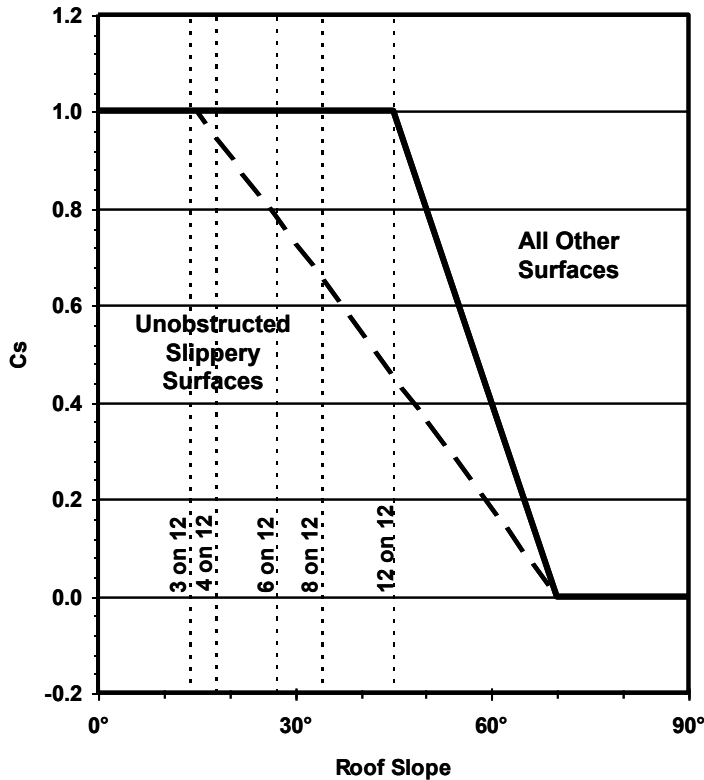

Figure 3.7.2.2.1 -1 Roof Factor  $C_s$  for cold roofs. (ASCE 7-05 Figure 7-2)

For almost every case, a covered bridge is not a bridge with high importance or considered essential. However, in extreme situations where a covered bridge is on a dead end roadway or where a detour would be excessive if the project required the removal of the bridge, consider the bridge essential. For bridge classifications, refer to Section 3.8.3.5. The importance factor will be:

- 1.0 for non-essential covered bridges. Most covered bridges will fall under this category.
- 1.1 for essential covered bridges.
- 1.2 for mandatory covered bridges. Covered bridges typically do not fall under this category.

$p_g$  = ground snow load from Figure 3.7.2 -1.

### 3.7.2.2.2 Unbalanced Roof Snow Load

Apply snow loads as specified in ASCE 7-05 section 7.6. This section assumes a hip and gable roof shape with slopes under  $70^\circ$  but greater than  $70/W + 0.5$  where  $W$  is the horizontal width from the eave to the ridge in feet. Do not investigate unbalanced snow loads on roofs with slopes over  $70^\circ$  or flatter than the result of the above equation. For other roof types, refer to ASCE 7-05 section 7.



Apply unbalanced snow load (Refer to Figure 3.7.2.2.2 -1):

- If  $W$  is less than or equal to 20 feet the covered bridge shall be designed with an unbalanced snow load of  $1p_g$  on the leeward side with no load on the windward side.
- If  $W$  is greater than 20 feet the covered bridge shall be designed with an unbalanced snow load of  $p_s$  on the leeward side with an addition load of  $hd / S0.5$  beginning at the peak and extending a distance of  $8(S0.5)hd / 3$ . Figure 3.7.2.2.2 -2 provides the value for  $hd$ . Design the windward side with an unbalanced load of  $0.3p_s$ . (ASCE 7-05 7.6.1).

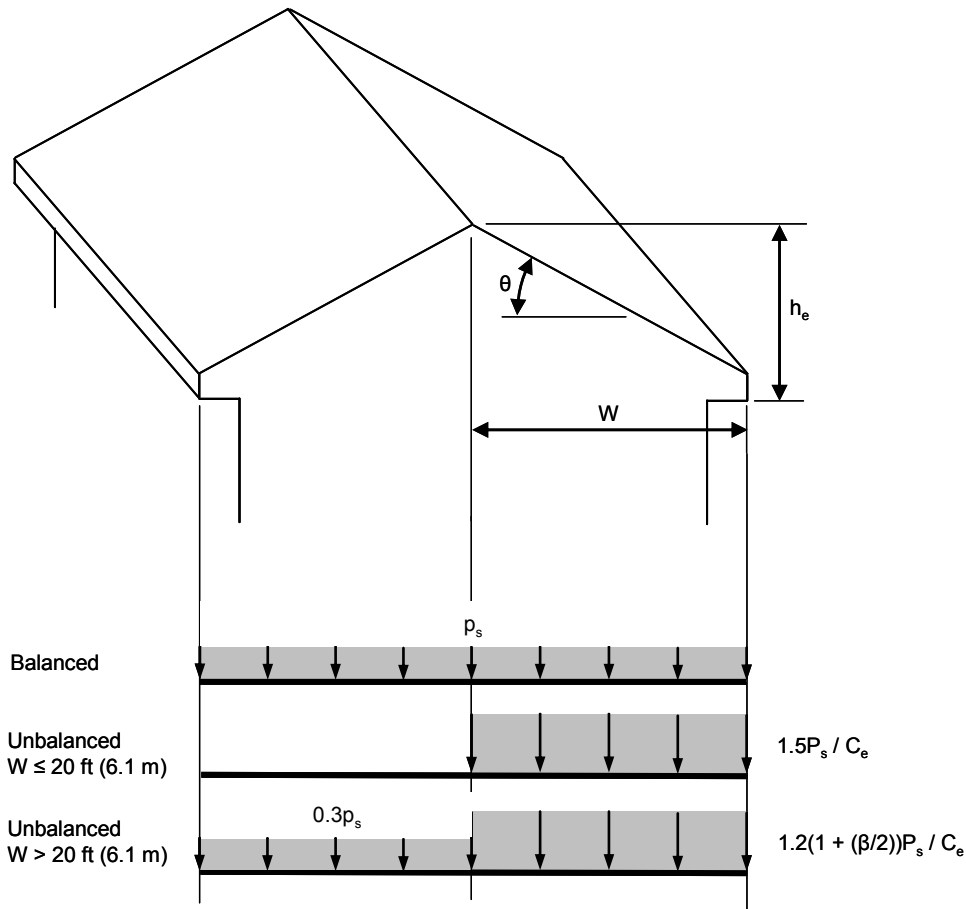

Figure 3.7.2.2.2 -1 Balanced and Unbalanced Snow Loads for Hip and Gable Roofs (ASCE 7-05 Figure 7-5)

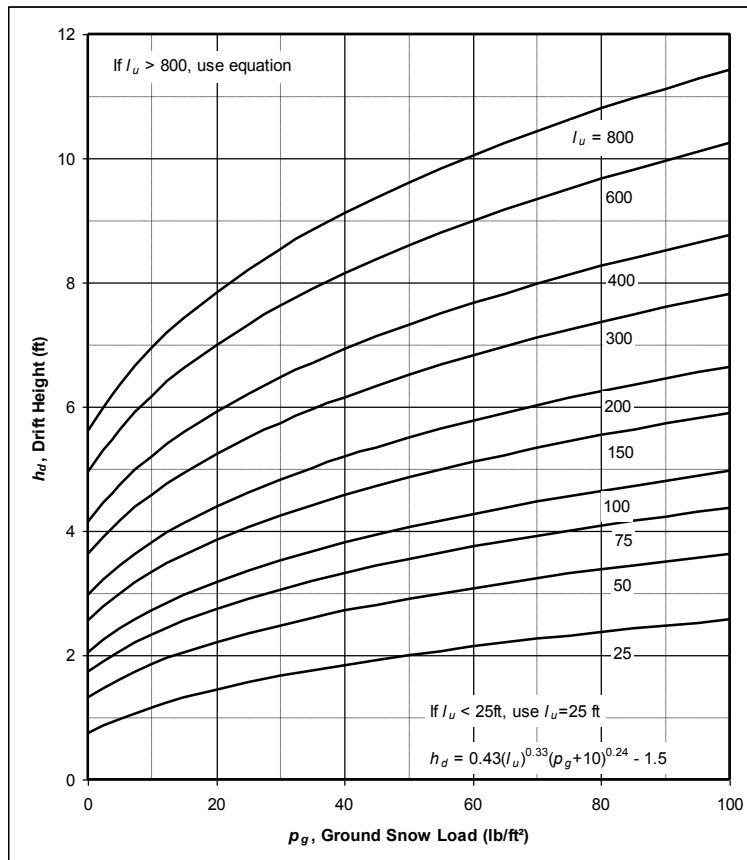

Figure 3.7.2.2.2 -2 Graph and Equation for Determining Drift Height,  $h_d$

To convert  $\text{lb/ft}^2$  to  $\text{kN/m}^2$ , multiply by 0.0479

To convert ft to m, multiply by 0.3048 (ASCE 7-05 Figure 7-9)

### 3.7.2.3 Ice Load on Signs

Use the latest edition of the AASHTO Standard Specifications for Structural Supports for Highway Signs, Luminaires, and Traffic Signals with all subsequent interims for the design of sign structures.

## 3.8 EARTHQUAKE EFFECTS (EQ)

Consider seismic effects in all new and rehabilitated structure designs.

### 3.8.1 Seismic Design Specifications

Consider seismic effects using the following specifications:

- New Structures: AASHTO LRFD Bridge Design Specifications with interims.
- Structure Rehabilitation: AASHTO LRFD Bridge Design Specifications with interims or the 2007 FHWA/MCEER Seismic Retrofitting Manual for Highway Structures: Part 1 – Bridges. (See Section 1.3.2)

### 3.8.2 Design Criteria

The Acceleration Coefficient map published in the LRFD Specifications is based on the 2002 NEHRP Recommended Provisions for the Development of Seismic Regulations for New Buildings. The 2006 International Building Code provides similar seismic maps. Figure 3.8.3 -1 is based on the 2004 NEHRP Recommended Provisions for the Development of Seismic Regulations for New Building. Refer to the 2004 NEHRP Commentary for more information (online at <http://www.bssconline.org>)

- Most bridge designs in Vermont will follow the requirements of Seismic Zone 1. Bridge designs in other than Bennington and Windham Counties in locations that qualify for Site Class E (weak soils) shall follow the requirements of Seismic Zone 2. Locations that qualify for Site Class F (peat or very soft clay) will need a site-specific analysis for Seismic Zone determination. (LRFD Section 3.10.3) Analyze seismic effects according to the LRFD Specifications. (See LRFD Section 3.10.3.1 for Site Class definitions)
- Single span bridges will not require a seismic analysis other than what is required for supports (LRFD Section 4.7.4.2). Multiple span bridges shall follow the provisions in LRFD Section 4.7.4.3.
- For bridge designs in Seismic Zone 1, use a force of 25% of the tributary vertical loads at any reaction as the horizontal connection restraining force. (LRFD Section 3.10.9.2)
- Bridge Designs in Seismic Zone 2 will required more in-depth analysis provided in LRFD Section 3.10.9.3.
- Obtain the structural importance factor from Section 3.8.3.5 .
- Design covered bridges using the AASHTO LRFD Bridge Design Specification, the National Design Specification (NDS) for Wood Construction (LRFD and ASD), the International Building Code and ASCE 7 Minimum Design Loads for Building and Other Structures.

### 3.8.3 Seismic Design for Covered Bridges

Design buildings, including covered bridge housing using the International Building Code accompanied by the ASCE 7 Minimum Design Loads for Buildings and Other Structures. Refer to Figure 3.8.3 -2 for the maximum considered earthquake ground motion for Vermont of 0.2 sec spectral response acceleration (SS). Refer to Figure 3.8.3 -1 for the maximum considered earthquake ground motion for Vermont of 1.0 sec spectral response acceleration (S1). The referenced figures show spectral response acceleration values for each town assuming five percent of critical damping and a site class B. Modify the values for actual site conditions. (International Building Code Section 1613)

#### 3.8.3.1 Bridge Decks of Covered Bridges

Use the AASHTO LRFD Bridge Design Specifications for the design of all bridge decks and abutments. Beginning with the 2008 Interims of the AASHTO LRFD Bridge Design Specifications, fourth edition, Seismic design has changed considerably.

#### 3.8.3.2 Site Class Definition

Refer to Table 1613.5.2 in the 2006 International Building Code for specific details regarding site classification. Table 3.8.3.2 -1 provides a brief description of each site class. (2006 IBC Section 1613.5.2 or LRFD Section 3.10.3.1)

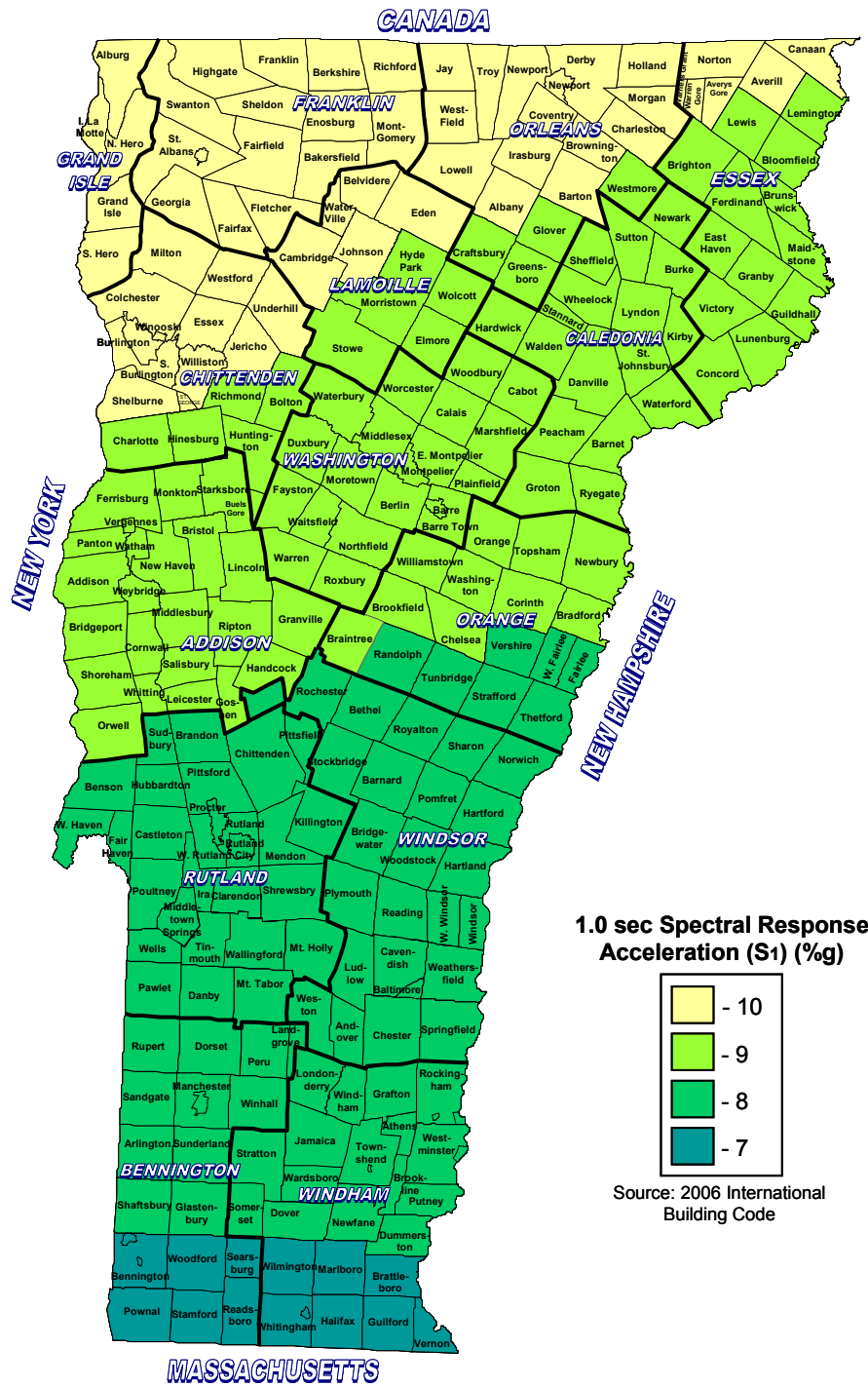

Figure 3.8.3 -1 Maximum Considered Earthquake ground motion for Vermont of 1.0 sec. Spectral Response Acceleration (S<sub>1</sub>) (5 percent of critical damping), Site Class B (2006 International Building Code)

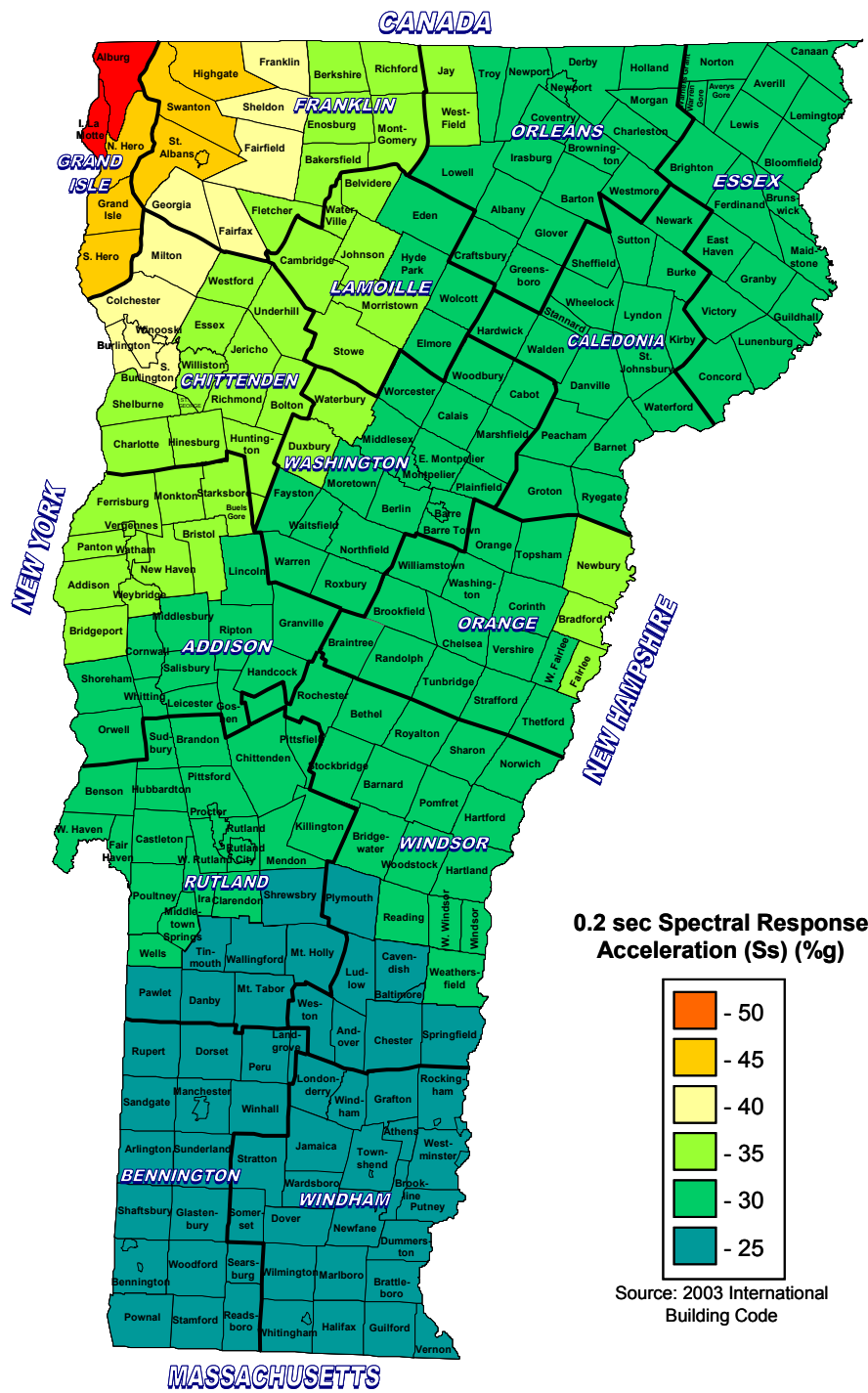

Figure 3.8.3 -2 Maximum Considered Earthquake ground motion for Vermont of 0.2 sec. Spectral Response Acceleration (Ss) (5 percent of critical damping), Site Class B (2006 International Building Code)

Table 3.8.3.2 -1 Site Class Definition

Site Class	Soil Profile Name
A	Hard Rock
B	Rock
C	Very Dense Soil and Soft Rock†
D	Stiff Soil Profile†
E	Soft Soil Profile
F	Liquefiable Soils
	Highly Sensitive Clays
	Peats or Organic Clays

† For the simplified design procedure, consider footings placed on a 10 feet or thinner layer of soil over rock as placed on rock. (ASCE 7-05 Section 12.14.8.1)

(2006 IBC 1613.5.2)

### 3.8.3.3 Adjustment to Mapped Spectral Response Acceleration Based on Site Class

Modify the site coefficients obtained in Section 3.8.3 if the site class definition is anything other than B. Table 3.8.3.3 -1 provides the site coefficient ( $F_a$ ) for the site class and mapped spectral response acceleration at short periods ( $S_s$ ) and the site coefficient ( $F_v$ ) for the site class and mapped spectral response acceleration at 1-second period ( $S_1$ ). (2006 IBC Section 1613.5.1)

The maximum considered earthquake spectral response acceleration for short periods (SMS) and the maximum considered earthquake spectral response acceleration for 1-second period (SM1) are determined as follows:

$$SMS = F_a S_s \quad (3.8.3.3 -1)$$

$$SM1 = F_v S_1 \quad (3.8.3.3 -2)$$

Table 3.8.3.3 -1 Values of Site Coefficients ( $F_a$  and  $F_v$ ) as a Function of Site Class and Mapped Spectral Response Acceleration at Short Periods ( $S_s$ ) and at 1-Second Period ( $S_1$ ) Respectively.

Site Class	$F_a$		Site Class	$F_v$
	Mapped Spectral Response Acceleration at Short Periods ( $S_s$ )			Mapped Spectral Response Acceleration at 1-second Period ( $S_1$ )
	$S_s \leq 0.25$	$S_s = 0.50$		$S_1 \leq 0.1$
A	0.8	0.8	A	0.8
B	1	1	B	1
C	1.2	1.2	C	1.7
D	1.6	1.4	D	2.4
E	2.5	1.7	E	3.5
F	†	†	F	†

† Consult the 2006 International Building Code.  
(2006 IBC 1613.5.3)

### 3.8.3.4 Design Spectral Response Acceleration Parameters

The five-percent damped design spectral response acceleration at short periods SDS and at 1 second period SD1 are calculated by taking two-thirds of SMS and SM1 calculated from Section 3.8.3.3 : (2006 IBC Section 1613.5.4)

$$SDS = \frac{2}{3}(SMS) \quad (3.8.3.4 -1)$$

$$SD1 = \frac{2}{3}(SM1) \quad (3.8.3.4 -2)$$

### 3.8.3.5 Use Category

Each building or covered bridge structure shall be assigned a seismic use category and a corresponding importance factor (IE) which can be obtained from Error! Reference source not found.. (2006 IBC Section 1604.5 and ASCE 7-05 Section 11.5)

### 3.8.3.6 Seismic Design Category

Assign each building or covered bridge structure to a seismic design category. Base the classification on the structure’s use category and the design spectral response acceleration coefficients SDS and SD1. Select the more severe design category from Table 3.8.3.6 -1 and Table 3.8.3.6 -2 to determine the Seismic Design Category for SDS and SD1 respectively. The designer need not consider seismic design category E and F for covered Bridges in Vermont. (2006 IBC Section 1613.5.6)

#### 3.8.3.6.1 Seismic Design Category Based on Ss Only

When all of the following apply, the seismic design category is determined from Table 3.8.3.6 -1 only.

- The approximate fundamental period of the covered bridge (Ta) is less than 0.8TS.
- The fundamental period of the covered bridge (T) is less than TS.
- The fundamental period of the covered bridge (T) is greater than TO and less than TS.

Table 3.8.3.6 -1 Seismic Design Category Based on Short-Period Response Accelerations

Value of SDS	Use Category	
	I or II	III
$S_{DS} < 0.167g$	A	A
$0.167g \leq S_{DS} < 0.33g$	B	C
$0.33g \leq S_{DS} < 0.50g$	C	D
$0.50g \leq S_{DS}$	D	D

(2006 IBC 1613.5.6)

Table 3.8.3.6 -2 Seismic Design Category Based on 1-Second Period Response Accelerations

Value of SD1	Use Category	
	I or II	III
$S_{D1} < 0.067g$	A	A
$0.067 \leq S_{D1} < 0.133g$	B	C
$0.133g \leq S_{D1} < 0.20g$	C	D
$0.20g \leq S_{D1}$	D	D

(2006 IBC 1613.5.6)

#### 3.8.3.6.2 Fundamental Period

Calculate the fundamental period of a structure as follows:

- Approximate fundamental period

$$T_a = 0.02(hn)^{0.75} \quad (3.8.3.6.2-1)$$

hn = the height of the covered bridge.

- Fundamental period upper limit

$$T = C_u T_a \quad (3.8.3.6.2-2)$$

Cu = interpolated from the following:

- 1.4 when SD1 is equaled to or greater than 0.3;
- 1.5 when SD1 equals 0.2;
- 1.6 when SD1 equals 0.15; or
- 1.7 when SD1 is equaled to or less than 0.1.

$$TS = SD1 / SDS \quad (3.8.3.6.2-3)$$

$$TO = 0.2TS \quad (3.8.3.6.2-4)$$

### 3.8.4 Design Requirements for Seismic Design Category A

Structures complying with seismic design category A will require only minimum seismic considerations listed below.

- To provide minimum structural integrity in the event of an earthquake, the structure should be designed to resist a lateral force of 1% of the dead load of the covered bridge housing
- The connection connecting smaller elements of the covered bridge to the rest of the structure should be capable of resisting a horizontal force of 5% of the weight of the smaller element. When using the simplified design procedure, the resistance of the connection shall be the greater of 0.2 times SDS or 0.05 both times the weight of the smaller element.
- The supports of beam, girders or trusses shall be capable of resisting a horizontal force of 5% of the dead load and anticipated live load carried by the covered bridge during an earthquake. Do not consider live load if the covered bridge truss or housing is self supported or otherwise separate of the bridge deck.

### 3.8.5 Simplified Analysis Procedure for Seismic Design of Covered Bridges Meeting Seismic Design Categories B and C

The designer should attempt to place covered bridges on locations satisfying site categories A through D. Covered bridges should not be considered essential (See Section 3.8.3.5 ) and therefore will be assigned to use category I. If the roadway is the only entrance into an area or VTrans considers the roadway vital in providing aid to an area, the designer may consider the bridge may essential and therefore be assigned to use category II. The simplified analysis procedure provided in this section is available for bridges assigned to use category I. Bridges in other use categories require additional design considerations from the IBC.

Model covered bridges as a combined seismic-force-resisting-system. Longitudinally, design the structure as a bearing wall system. The bridge trusses will be required to transfer the horizontal roof shear forces in the longitudinal direction to the bearings. Laterally, the structure shall be designed as a building frame system – capable of resisting a sideway collapse.

For seismic design category B, apply seismic forces either laterally or longitudinally, separately. (ASCE 7-05 Section 12.14.6)

For seismic design category C, apply seismic forces in the most critical condition of 100% on one direction plus 30% of the perpendicular direction.

In either case, do not consider seismic loads applied at angles in between each of the orthogonal directions.



### 3.8.5.1 Seismic Base Shear

The seismic base shear for the covered bridge shall be determined with the equation: (2006 IBC 1617.5.1)

$$V = SDSW / R \quad (3.8.5.1 -1)$$

where:

SDS From Section 3.8.3.4 .

W = Effective seismic weight including dead weight of the entire covered bridge plus 20 percent of flat roof snow load. The weight of the bridge deck need not be included in W.

R = Response modification factor  
 = 2.0 – For Longitudinal trusses  
 = 2.5 – For Lateral Frames

### 3.8.5.2 Vertical Distribution

The seismic base shear shall be distributed vertically in the covered bridge as follows:

- $F_{roof} = V(w_{roof} / W)$  for the roof acting at the top of the roof
- $F_1 = V$  for the entire weight of the covered bridge acting at the base of the roof
- Where  $w_{roof}$  is the portion of the effective seismic weight (W), as defined above, for the roof level. (ASCE 7-05 Section 12.14.8.2)

### 3.8.5.3 Horizontal Shear Distribution

The seismic design shear at each level is calculated as (ASCE 7-05 Section 12.14.8.3):

- $V_{roof} = F_{roof}$  acting at the roof base
- $V_1 = F_1$  acting at the base of the covered bridge.

The structure shall resist the shear force at the base of each level.

### 3.8.5.4 Anchorage of Covered Bridge

The vertical resistance of the anchorages of the covered bridge shall be the maximum of (ASCE 7-05 Section 12.14.7.6):

$$F_p = 0.4SDSW_c \quad (3.8.5.4 -1)$$

$$F_p = 0.1W_c \quad (3.8.5.4 -2)$$

Where  $W_c$  is the tributary weight of the covered bridge at the point of support.

### 3.8.5.5 Seismic Load Effects and Combinations

When using the load combination  $1.2DL + 1.0E + f_{IL} + 0.2S$ :

$$E = E_h + E_v \quad (3.8.5.5 -1)$$

When using the load combination  $0.9DL + 1.0E$

$$E = E_h - E_v \quad (3.8.5.5 -2)$$

Where:

$$E_h = Q_E \quad (3.8.5.5 -3)$$

$$E_v = 0.2SDSD \quad (3.8.5.5 -4)$$

$Q_E$  = effects of horizontal seismic forces from V and  $F_p$  calculated above

$D$  = effects of dead load

$f_l$  = refer to Section 3.2.1.1

Express both load cases as:

$$(1.2 + 0.2SDS)D + Q_E + f_l L + 0.2S \quad (3.8.5.5 -5)$$

$$(0.9 - 0.2 SDS)D + Q_E \quad (3.8.5.5 -6)$$

### 3.8.5.6 Overturning

The structure must resist overturning effects caused by seismic forces at each level in the covered bridge design.

### 3.8.5.7 Structural Drift

Calculating the structural drift of the covered bridge is not required for the simplified design procedure. If drift values are required for construction or material tolerances, use a maximum of 1% of the height of the covered bridge. (ASCE 7-05 Section 12.14.8.5)

## 3.8.6 Design Requirements for Seismic Design Category D

Calculate the earth load effects according to LRFD Section 3.11. Considering Section 3.3.1, use 0.140 k/f<sup>3</sup> for the soil unit weight unless more accurate local soil data is available. For Rankine Coefficient values, refer to Figure 3.3.5 -1.

Design covered bridges that meet the requirements for Seismic Design Category D according to the additional requirements of the IBC.

## 3.9 EARTH PRESSURE (EH, ES, LS AND DD)

The Item Granular Backfill for Structures is a free draining material for which the Rankine Earth Pressure Theory is applicable.

$\delta$  = friction angle between fill and wall = 0°

$\phi$  = effective angle of internal friction = 34° (The Lab can provide more accurate values based on the site conditions)

$\gamma_s$  = unit weight of soil 140 lb/ft<sup>3</sup>

OCR= overconsolidation ratio = 1

Use LRFD Table 3.11.5.3-1 to obtain the coefficients of friction between the backwall/footing and soil. Ignore friction between the backwall and the backfill when using cohesionless backfill behind a vertical or near vertical wall.

### **3.10 FORCE EFFECTS DUE TO SUPERIMPOSED DEFORMATIONS (TU, TG, SH, CR AND SE)**

Consider force effects caused by super-imposed deformations as prescribed in LRFD Article 3.12 with the additional considerations of this section.

#### **3.10.1 Thermal Forces**

Evaluate thermal forces for the cold climate temperature range. Use AASHTO LRFD 3.12.2 “Uniform Temperature” Procedures A or B.

Coefficients of Thermal Expansion ( $\alpha$ ) from AASHTO LRFD are:

- 0.000006/°F for Concrete.
- 0.000065/°F for Steel.
- 0.000013/°F for Aluminum.

The design temperature ranges for procedure A are:

- 0°F to 80°F for Concrete.
- -30°F to 120°F for Steel.
- 0°F to 75°F for Wood.

For internal forces in buried concrete frame structures, a temperature rise of 35°F and a temperature fall of 45°F should be considered in design.

For Procedure B, refer to LRFD Section 3.12.2.2.

### **3.11 FRICTION FORCES**

As stated in LRFD 3.13, use the extreme values for the friction coefficient between surfaces modified as appropriate with expected moisture that may be present. Table 3.11 -1 is a compilation of several common coefficient values obtained from various sources.

Table 3.11 -1 Values for Friction Coefficients

<b>Contact Material</b>	<b>Condition</b>	<b>Dynamic</b>	<b>Static</b>	<b>Range</b>
Aluminum on Aluminum	dry	1.05	1.40	±0.28
Brick on Brick (Hard)	dry	0.53	0.70	---
Bronze on Steel	oiled	---	0.09	---
Cast Iron on Brake Lining	dry	0.35	0.45	±0.05
Cast Iron on Cast Iron	dry	0.15	1.10	---
Concrete on Concrete (blocks)	dry	0.49	0.65	---
Concrete on Rubber	dry	0.57	0.75	±0.14
Earth on Earth	dry	0.45	0.60	±0.35
Grooved Rubber on Pavement	dry	0.65	0.80	±0.05
Leather on Metal	dry	0.36	0.47	±0.14
Leather on Wood	dry	0.35	0.45	±0.05
Masonry on Clay	dry	0.41	0.55	±0.05
Masonry on Clay	wet	0.25	0.33	---
Masonry on Gravel	dry	0.45	0.60	---
Masonry on Masonry	dry	0.49	0.65	±0.05
Masonry on Masonry w/ mortar	wet	0.56	0.75	---
Masonry on Sand	dry	0.30	0.40	---
Metal on Ice	wet	0.03	0.04	±0.01
Metal on Leather	dry	0.36	0.47	±0.14
Metal on Metal	dry	0.29	0.38	±0.19
Metal on Stone	dry	0.38	0.50	±0.17
Metal on Wood	dry	0.30	0.40	±0.17
Plastic on Steel	dry	0.35	---	---
Press fits (Shaft in Hole)	oiled	---	0.13	±0.02
Rubber on Concrete	dry	0.57	0.75	±0.14
Steel on Asbestos-faced Steel	dry	---	0.15	---
Steel on Asbestos-faced Steel	oiled	---	0.12	---
Steel on Bronze	oiled	---	0.09	---
Steel on Graphite	dry	---	0.21	---
Steel on Self-Lubricating Brass (bearings)	dry	---	0.10	---
Steel on Plastic	dry	0.35	---	---
Steel on Steel	dry	0.42	0.78	---
Steel on Steel (smoothed - bearings)	dry	---	0.15	---
Steel on Steel	oiled	0.08	0.10	---
Stone on Metal	dry	0.38	0.50	±0.17
Stone on Stone	dry	0.42	0.55	±0.14
Stone on Wood	dry	0.30	0.40	---
Teflon (PTFE) on Stainless Steel (bearings)	dry	---	0.06	---
Wood on Leather	dry	0.35	0.45	±0.05
Wood on Metal	dry	0.30	0.40	±0.17
Wood on Stone	dry	0.30	0.40	---
Wood on Wood	dry	0.38	0.45	±0.12

## 3.12 CONSTRUCTION LOADS

The designer should consider construction loads. Unless project specific information is available, designers should use the loads designated in Table 3.12 -1.

### 3.12.1 Formwork

Design for temporary formwork, but allow for stay-in-place formwork. A redesign or a design check of the deck will be required, if the Contractor decides to use stay-in-place formwork.

For conventional formwork (plywood, etc.) assume a uniform dead load of 0.010 k/ft<sup>2</sup>. In addition to dead loads, design concrete formwork with a construction live load of 0.050 k/ft<sup>2</sup>.

### 3.12.2 Structural Elements

Assume structural elements that support formwork to have a larger tributary area and consequently have a smaller construction live load than formwork of 0.020 k/ft<sup>2</sup>.

### 3.12.3 Construction Live Load

#### 3.12.3.1 Temporary Live Loads

Design temporary bridges for HL-93 live load at a minimum of the posted rating.

Table 3.12 -1 Construction Loads<sup>4</sup>

Load Description	Unit Weight (k/ft <sup>2</sup> )
Screed (LL)	0.450 k/ft†
Equipment (LL)	0.005 k/ft <sup>2</sup>
Temporary Forms	0.010 k/ft <sup>2</sup>
Temporary Railing	0.030 k/ft

† Spread out over 10 ft

---

<sup>4</sup> Values obtain from various examples from State Transportation Agencies.

## SECTION 4: STRUCTURAL ANALYSIS AND EVALUATION

### 4.1 GENERAL INFORMATION

The analysis of bridges and structures is a mixture of science and engineering judgment. In most cases, use simple models with conservative assumptions to arrive at the design forces for various elements. For example, for straight beam bridges with small skews, use beam line models with approximate distribution factors to arrive at the design moments, shears and reactions. For structures that have significant complexity or for situations where refinement offers significant benefits, consider a more refined or rigorous analysis (e.g., grid or 3D finite element). Situations where this might be appropriate include, curved bridges, bridges with large skews, or when evaluating the critical element of a bridge with marginal live load capacity.

Satisfying force equilibrium and identifying a load path to transfer superstructure loads to the foundations is the primary analysis goal for designers.

The remainder of this section contains guidance on a variety of topics. Topics include computer programs, load distribution, load rating, substructure fixity and lastly, LRFD exceptions.

### 4.2 SOFTWARE

Engineering software (i.e. Conspan, Merlin Dash, etc.), MathCAD sheets and spreadsheets play a large role in the design of bridges. Using Software does not remove the responsibility of the Structural Engineer to verify (through hand calculations, other programs, past experience, etc) that results are accurate. VTrans maintains a list of these resources at [http://vtransengineering.vermont.gov/sections/structures/design\\_tools](http://vtransengineering.vermont.gov/sections/structures/design_tools).

Consultants may use any software programs and/or spreadsheet for their internal design or analysis work. The Structures Section does not have any requirements for such software. The Structures Section however, requires the Consultant to provide an electronic copy of the final input files compatible with the primary design software designated herein along with an electronic copy of the output from which they derived the design or their hand design calculation checks. At the completion of the design phase, the Consultant shall submit the electronic files to the Structures Section on physical electronic media such as a CD-R, Flash Drive or other electronic media compatible with current standard desktop computer equipment. Consultants may also make these files available via their internal ftp site or upload them to the Agencies ftp site. Included in this submittal shall be required material including design calculations performed by hand or other software, details and plans.

In some cases, this may mean the Consultant will be required to produce input files for software required by the Structures Section in addition to their internal software. The Consultant shall use software designated by the Structures Section as a verification tool for the results of their internal design software.

#### 4.2.1 3D/2D Finite Element Modeling

The Structures Section uses the RISA 3D general-purpose 3-dimensional analysis and design program for finite element analysis. RISA 3D may be used to analyze structures with more detail than what is possible with other design software listed in this section. RISA 3D may be used to obtain more detailed values for live load distribution factors. RISA 3D is currently compatible with basic STAAD files.

Consultants must submit any RISA 3D model along with their design calculations. If the Consultant uses STAAD, the STAAD model must be sent in as a substitute for a RISA 3D file, so long as the model can be translated to RISA 3D. The Consultant may contact RISA at <http://www.risa.com> for more information on STAAD compatibility.

#### 4.2.2 General Design

The Structures Section standardized on MathCAD and the Excel spreadsheet for the preferred general design environments. These environments are ideal for checking design software, creating design or analysis templates, doing custom designs or analyses and finally providing an open user based development platform. The Structures Section's preference is to focus all development in MathCAD. However, each environment has its own unique features and when used together, complements each other.

### **4.2.3 Prestress Concrete Design**

The Structures Section uses the Conspan software from Bentley Systems Inc. (Formally LEAP Software) as the primary software for designing, analyzing and load rating prestress concrete beam decks. VTrans has a history of using voided slabs, box beams and AASHTO I's, all of which the software accommodates. New England Bulb T's and NEXT Beams are new sections developed by PCI Northeast for use in the New England and New York. The software can also accommodate these sections.

### **4.2.4 Steel Beam Design**

The Structures Section uses the Merlin DASH and Descus software from Opti-Mate as the primary software for designing, analyzing and load rating steel beam bridge decks. Merlin DASH helps in the design of straight beam decks and Descus helps in the design of curved beam decks. Currently Descus does not provide load-rating capabilities.

### **4.2.5 Pile Design and Analysis**

The Structures Section uses FB-Multiplier as the primary design software for designing and analyzing piles used for supporting footings or pile caps.

## **4.3 LOAD DISTRIBUTION**

The LRFD Specifications encourage the use of either refined or approximate methods of analysis. Utilize an approximate method of analysis to determine the lateral live-load distribution to individual girders for typical highway bridges. Lateral live-load distribution factors are dependent on multiple characteristics of each bridge. There are specific ranges of applicability for the use of approximate methods of analysis. Extending the application of such approximate methods beyond the limits requires sound and reasonable judgment. Otherwise, use a refined analytical method.

### **4.3.1 Dead Load Distribution**

#### **4.3.1.1 Bridge Decks with Curved Beams**

This section applies to bridge decks with straight beams. Bridge decks on curved beams that meet LRFD Section 4.6.2.2.1 may follow the guidance in this section for straight beams. The only exception is that heavier weights from barriers or sidewalks may require a more detailed distribution over the beams, specifically in relation to the exterior beam on the outer side of the bridge deck. The designer shall refer to the AASHTO LRFD Bridge Design Specifications (Section 4.6.1.2) for more detailed guidance on how to distribute permanent loads over the beams.

#### **4.3.1.2 Non-compliant Bridge Decks**

Bridge decks not compliant with LRFD Section 4.6.2.2.1 will require more a more detailed analysis for the distribution of permanent loads.

#### **4.3.1.3 Deck, Wearing Course, Future Wearing Surface, Railing, Barriers, and Medians**

For beam bridges, distribute the dead load of the deck to the beams based on their respective tributary widths. Distribute superimposed dead loads, such as the wearing course, future wearing surface, railings, barriers, sidewalks and medians equally to all beam lines.

For reinforced concrete slab bridges, distribute the weight of the barrier railing loads to the edge strip. For design of the interior strip, distribute the weight of the barriers across the entire width of the slab and combined with other superimposed dead loads.

#### 4.3.1.4 Miscellaneous Loads - Conduits, Sign Structure, etc.

Distribute conduit loads supported by hangers attached to the deck equally to all beams. Assume the exterior beam carries the load of sign structures, architectural treatment panels and sound walls, which act entirely outside the exterior beam.

### 4.3.2 Live Load Distribution

The LRFD Specifications provides the equations and tables for live load distribution factors. See LRFD Section 4.6.2.2. For typical beam bridges, distribution factors are provided for interior beam flexure (single lane, multiple lanes, and fatigue), Interior beam shear (single lane, multiple lanes, and fatigue). Use controlling value of the lever rule and AASHTO distribution formulas to determine the amount of live load carried by the exterior beam. LRFD C4.6.2.2.2d provides a formula for computation of an additional distribution factor for bridges that have diaphragms or cross-frames. Use of the rigid cross-section or pile-equation distribution factor is not required for design of exterior beams.

For the interior and exterior beams, the designer shall use the controlling (or larger) distribution factor calculated for one lane loaded, two lanes loaded or three or more lanes loaded for flexure. Do the same for shear for locations within the span and at the supports. The controlling distribution factor will be the larger of these.

When checking deflection, the distribution factor shall be the maximum number of lanes loaded divided by the number of beams and multiplied by the respective multiple-presence factor.

The designer shall also calculate the fatigue distribution factors similarly as above except only consider one lane loaded.

#### 4.3.2.1 Steel and Prestressed Concrete Beams

Unlike the Standard Specifications, the live load distribution factors for beam bridges are dependent on the stiffness of the components that make up the cross section [LRFD Equation 4.6.2.2.1-1]. Use Engineering judgment in determining the appropriate distribution factors for each section within a girder. For simple span structures with continuous beam sections, a single live load distribution factor (computed at mid span) may be used. For continuous structures, use a single distribution factor for each positive moment region and for each negative moment region. For bridges with consistent geometry (continuous girder section, same number of beam lines in each span, etc.), use the largest positive moment distribution factor for all positive moment locations. Similarly, use the largest negative moment distribution factor for all negative moment regions.

#### 4.3.2.2 Slab Spans and Timber Decks

The LRFD Specifications provide equations for distribution factors that result in equivalent strip widths,  $E$ , that are assumed to carry one lane of traffic. Convert the equivalent strip width to a live load distribution factor (LLDF) for the unit strip by taking the reciprocal of the width.

$$\text{LLDF} = 1/E \quad (4.3.2.2 - 1)$$

### 4.3.3 Pedestrian Bridge Live Load

Design pedestrian bridges for the HV-05-09 maintenance vehicle for deck widths between 6-10 feet, and an HV-10-09 truck for wider decks (See Section 3.4.6 ). Use of the dynamic load allowance is not required with the maintenance vehicle. These live loads need not be applied for trail bridges which are not going to be plowed. However, in this case be sure to include the snow loads from Section 3.7.2 .

## 4.4 SUBSTRUCTURE FIXITY

Examine the overall fixity of the bridge in detail for bridges on steep grades; moderate to severe curvature or when the columns are tall or slender. Follow the guidelines below for providing fixity at bearings.

Fix the downhill bearings for bridges on grades, except for a simple span bridge where one of the substructure units is founded on bedrock. In this case, the fixed support will be located on the substructure unit founded on bedrock



regardless of elevation. For longer bridges, consider the flexibility of each pier and its bearings to determine the appropriate substructure units to fix.

If pier flexibility and geometry permit, use a minimum of two fixed piers per expansion joint unit. For very flexible piers, such as pile bents or slender columns, the expansion bearings may be redundant (the pier may move before the bearings begin to slide).

#### ***4.5 STRUCTURAL MODELS***

For redundant structures, the distribution of internal forces is dependent on member stiffness. Use engineering judgment when assigning member properties and boundary conditions to determine the internal forces of members.

Often using a simplified method may help in arriving at a solution. For example, instead of setting up a continuous beam model, design moments in pile bent pier caps can be determined in the following manner: Positive moment requirements can be determined by assuming simple spans between the supporting piles. Compute the required negative moment capacity assuming a propped cantilever for the outside spans and fixed/fixed boundary conditions for the interior spans.

#### ***4.6 RAILROAD BRIDGES & BRIDGES OR STRUCTURES NEAR RAILROADS***

Design railroad bridges in accordance with the most current American Railway Engineering and Maintenance-of-Way Association (AREMA) Specifications.

Designers should be aware that railroads often have specific criteria for design of structural components, carrying their tracks or in the vicinity of their tracks. The criterion can vary between different railroad companies.

## SECTION 5: CONCRETE STRUCTURES

### 5.1 MATERIAL PROPERTIES

#### 5.1.1 Concrete Types

Refer to the latest VTrans Standard Specifications for Construction for more detailed information regarding the different requirements for each concrete product that VTrans uses. Section 501 provides the standard requirements for cast-in-place high performance structural concrete. Section 510 provides the requirements for prestressed concrete. Section 540 provides the requirements for precast concrete. Section 541 provides the requirements for cast-in-place structural concrete. A description for reinforcing steel can be found in Section 507.

When using multiple types of concrete or reinforcement in a project, the designer must clearly show the location of each material on the plans.

##### 5.1.1.1 High Performance Concrete

The American Concrete Institute defines high performance concrete as “concrete that meets special performance and uniformity requirements that cannot always be achieved routinely by using only conventional materials and normal mixing, placing, and curing practices.” This is VTran’s chosen mix for cast-in-place structural concrete. High Performance Concrete is broken up into five classes as described below:

###### 5.1.1.1.1 HP Class AA

This class of concrete has a smaller maximum course aggregate size and may be used in cast-in-place thin deck overlays where aggregate size may be an issue.

###### 5.1.1.1.2 HP Class A

This class of concrete is primarily used when cast-in-place concrete is required in bridge superstructures.

###### 5.1.1.1.3 HP Class B

This class of concrete is primarily used when cast-in-place concrete is required in bridge substructures.

###### 5.1.1.1.4 HP Class SCC<sup>1</sup>

This class of concrete is self-consolidating concrete, otherwise known as self-compacting concrete. This concrete requires very little or no vibration or other mechanical means to consolidate the plastic concrete. This type of concrete should be used when it may be difficult or unadvisable to provide vibration to the concrete due to its shape or location. This type of Concrete should not be used on a slope greater than 2%.

###### 5.1.1.1.5 HP Class LW<sup>1</sup>

This class of concrete uses is generally produced by using a lightweight aggregate so that the density is less than that of normal weight concrete. This concrete may be used when it is desired to reduce the weight of certain bridge components.

#### 5.1.1.2 Precast Concrete

Precast Concrete is concrete that is cast into reusable forms, cured in a controlled environment, transported to the construction site, and then lifted into place. Significant construction time is saved because the forming and field cure times of cast-in-place concrete can be avoided. This type of concrete is used in accelerated bridge construction.

---

<sup>1</sup> These mix classes have an increase in cost and should only be used if a need exists.

### 5.1.1.3 Prestressed Concrete

Prestressed concrete is a type of precast concrete that is pre-tensioned allowing it to carry a greater load or span a greater distance than ordinary reinforced concrete. This type of concrete is used in box beams, voided slabs, concrete girders, and NEXT beams.

### 5.1.1.4 Structural Concrete

This is a standard concrete mix that VTrans rarely uses in structures, with the exception of the Class C type of this mix which is used in subfootings.

### 5.1.1.5 Uses for Concrete Classes

The following table provides information on the type of Cast-in-Place Concrete normally used on each bridge component. The designer reserves the right to use an alternate mix if required by design.

Table 5.1.1.1 -1 Design Concrete Mix Summary

Location/Component	Concrete Class	Unit Weight* (lbs/cf)	Design Compressive Strength (ksi)**	Maximum Aggregate Size (in)
thin deck overlays where aggregate size may be an issue	HPC AA	150	4	1/2
decks, railings, medians, sidewalks, curtain walls, all concrete for integral abutment bridges above the bridge seat (including wingwalls)	HPC A	150	4	1
slab bridges, backwalls, abutment stems, footings, pile caps, wingwalls, pier columns and caps, drilled shafts, all concrete below the bridge seat of integral abutments	HPC B	150	3.5	2
railings, custom pieces where it may be difficult or unadvisable to provide vibration to the concrete due to its shape or location.	HPC SCC	150	3.5	N/A
This concrete may be used when it is desired to reduce the weight of certain bridge components.	HPC LW	95-120	4	1
Fill from top of rock to bottom of footing for spread footings (subfootings)	C	150	3.0	2

\* Weight is of unreinforced concrete. The unit weight of concrete with reinforcement is usually taken as .005 kips/cubic foot greater than the unit weight of plain concrete. For concrete strengths greater than 5 ksi the following equation should be used:

$$145 + .001 * f'c$$

Prestressed and precast concrete shall be used as design and construction dictates. The design strength of precast concrete is 5 ksi per Standard Specification Section 540. The design strength for prestressed concrete must be indicated on the plans. Currently, strengths up to 8 ksi are common for prestress members. The unit weight of precast or prestressed members (lbs/cf) shall be calculated using the following equation  $145 + .001 * f'c$ . If aggregate size is a concern because of tight reinforcement spacing or other constraints than the maximum aggregate size to be used in the mix design for precast or prestressed members shall be indicated on the plans.

### 5.1.1.6 Release Strength

When defining the release strength ( $f'ci$ ), use a maximum of 80% of the specified concrete strength ( $f'c$ ). For concrete strengths of 7 ksi or greater, consider setting the release strength no higher than 5.5 ksi. However, higher

release strengths may be considered if required by design. A precast plant can typically “turn over” a form in 24 hours with lower release strengths. Taking advantage of this, will keep the costs of prestressed beams down.

### 5.1.1.7 Coefficient of Thermal Expansion

According to LRFD Section 5.4.2.2, the thermal coefficient of expansion is dependent on the concrete mix. The coefficient of thermal expansion ( $\alpha$ ) for normal weight concrete is  $0.000006/^\circ\text{F}$  and for lightweight concrete,  $0.000005/^\circ\text{F}$ .

These values may vary. Mixes with limestone and marble aggregates have lower values whereas mixes with cherts and quartzite aggregates have higher values.

## 5.1.2 Reinforcing

### 5.1.2.1 Sizes of Reinforcing Steel

Use Grade 60, AASHTO M31 billet-steel bars for reinforcement in all reinforced concrete designs. Table 5.1.2.1 -1 lists the bar sizes. The modulus of elasticity for mild steel reinforcing ( $E_s$ ) is 29,000 ksi.

Table 5.1.2.1 -1 Reinforcing Bar Diameters, Areas and Weights

Bar Size US	Diameter (in)	Area (in <sup>2</sup> )	Weight (lb/ft)
3	0.375	0.11	0.374
4	0.500	0.20	0.681
5	0.625	0.31	1.055
6	0.750	0.44	1.497
7	0.875	0.60	2.042
8	1.000	0.79	2.688
9	1.128	1.00	3.403
10	1.270	1.27	4.322
11	1.410	1.56	5.308

### 5.1.2.2 Types of Reinforcing Steel

Research completed by the Materials and Research Section on corrosion on a wide variety of reinforcing steel bars indicated that the various reinforcing steels available for use can be broken down into the following three different levels of corrosion resistance:

Level I (Limited Corrosion Resistance) – Plain, Low Alloy, and Epoxy Coated Reinforcing Steel

Level II (Improved Corrosion Resistance) – Stainless Clad and Dual-Coated Reinforcing Steel

Level III (Exceptional Corrosion Resistance) – Solid Stainless Reinforcing Steel

The reinforcing steel type used in a component should match the existing steel used in that component for a partial replacement or widening project.

Level I – Level I reinforcing steel shall be used in all locations not designated as requiring Level II or Level III corrosion protection.

The following locations shall utilize reinforcing steel with Level II or Level III corrosion protection:

- Bridge superstructure concrete, including decks, slabs, curbs and railing;
- Back walls and curtain walls above the bridge seat;
- Piers caps; and
- Tunnels or substructures in a tunnel-like environment likely to be exposed to salt water or salt spray from plowing operations

Level III – Level III reinforcing steel shall be utilized in those locations listed above for any of the following scenarios:

- Interstate structures,
- NHS structures, and
- Site where extended service life is desirable due to the high cost and/or difficulty of bridge maintenance or construction.

Level II – Level II reinforcing steel shall be utilized in those locations listed above where Level III reinforcing steel is not warranted, i.e. non-NHS State and Town highway structures.

Level I (Epoxy Coated) – Epoxy coated reinforcing steel may be substituted for Level II or III reinforcing steel in those locations listed above for either of the following scenarios:

- An unpaved road with and ADT  $\leq 400$ ; or
- Components having a reduced design life. For example, a deck replacement on existing beams or substructure, where the intended design life is 30 years or less.

The following guidance should be considered when detailing reinforcement steel.

Coated reinforcing steel is difficult to effectively repair in the field and stainless steel is difficult to cut in the field. Thus, the designer should try to limit the number of reinforcing bars detailed to be cut-to-fit in the field.

### 5.1.2.3 Prestressing Steel Strands

- Uncoated low-relaxation 7-wire strand or uncoated deformed. Strands shall conform to AASHTO M223.
- The modulus of elasticity for prestressing steels is  $E_p = 28,500$  ksi.
- Use standard 7-wire low-relaxed 0.6 inch diameter<sup>2</sup> prestressing strand with a cross section area = 0.217 in<sup>2</sup> for longitudinal pre-tensioning and longitudinal post-tensioning strand for prestress beams and girders.

### 5.1.2.4 Transverse Post-Tensioning Tendons

Preferably, use standard 7-wire, 0.6 inch diameter<sup>2</sup>, low-relaxation strands for transverse post tensioning strand. For certain box beam configurations, it may be preferable to specify 0.5 inch low-relaxation strand. 0.5 inch strand has an area = 0.153 in<sup>2</sup>/strand.

### 5.1.2.5 Mechanical or Welded Reinforcing Splices

Contractors will select reinforcement bar couplers that meet the requirements stated in the special provisions. In general, the connectors need to:

- Provide a capacity that is 125% of the nominal bar capacity.
- Coupler coating or lack of coating shall match the connecting reinforcing steel.
- Do not mix epoxy coated or black steel in couplers.
- Satisfy the fatigue testing requirements of NCHRP Project 10-35 (12 ksi).
- Welding lap splices is acceptable, but the rebar needs to meet the requirements of ASTM A706 and should be designated on the plans as “ASTM A706 (WELDABLE)”. You should also indicate on the project drawings, specifications, or general notes that “The welding of reinforcing bars shall conform to the ANSI/AWS D1.4 Welding Code.”

---

<sup>2</sup> For metric designs, it is appropriate to refer to 0.6” diameter strand as simply “0.6 strand” or “six-tenths strand.”

### 5.1.2.6 Minimum Concrete Cover

Table 5.1.2.6 -1 includes calculated cover for reinforcing steel. Cover to ties and stirrups may be 0.5 in. (12 mm) less than the values specified in the Table for main bars but shall not be less than 1.0 in (25 mm).

Table 5.1.2.6 -1 Cover for Unprotected Main Reinforcing Steel [inch]

Situation	Example(s)	Cover (in.)
Cast against earth	Footings	3.0
Coastal		3.0
Exposure to deicing salts	Curbs, Sidewalks & Walls exposed face	3.0
Deck surfaces subject to tire stud or chain wear	Decks & Slab bridges	
• Paved deck		2.5
• Bare deck		3.0
Exterior other than above	Walls buried face	2.0
Interior other than above		
• Up to No. 11 bar		1.5
• No. 14 and No. 18 bars		2.0
Bottom of cast-in-place slabs		
• Up to No. 11 bar	Decks & Slab bridges	1.5
• No. 14 and No. 18 bars		2.0
Precast soffit form panels		0.8
Piers – all components except footings		4.0
Precast reinforced piles		
• Noncorrosive environments		2.0
• Corrosive environments		3.0
Precast prestressed piles		2.0
Cast-in-place piles		
• Noncorrosive environments		2.0
• Corrosive environments		
○ General		3.0
○ Protected		3.0
• Shells		2.0
• Auger-cast, tremie concrete, or slurry construction		3.0

### 5.1.3 Concrete Anchors

Anchor systems into concrete utilizing adhesives such as epoxy for permanent sustained tension load applications or for overhead applications is not allowed on VTrans Structures projects.<sup>3</sup>

<sup>3</sup> The basis for this moratorium on the use of anchor systems utilizing adhesives is a technical advisory T 5140.26 issued by FHWA on October 17, 2007.

## 5.2 CAST-IN-PLACE CONCRETE DETAILS

### 5.2.1 Minimum Concrete Thickness

#### 5.2.1.1 Concrete Deck Slabs on Longitudinal Components (Beams)

##### 5.2.1.1.1 Minimum Deck Thickness

- Paved Deck: 8½ inches minimum deck thickness
- Bare Deck: 9 inches minimum deck thickness

#### 5.2.1.2 Walls

Table 5.2.1.2 -1 Minimum Wall Thickness

Height Range	Minimum Wall Thickness
Height < 5 feet	12 inches
Height 5 feet to 10 feet	15 inches
Height > 10 feet	18 inches

#### 5.2.1.3 Footings

##### 5.2.1.3.1 Minimum Footing Thickness

- Spread footing – 2 feet
- Footing on Piles – 3 feet

### 5.2.2 Joints in Concrete

#### 5.2.2.1 Horizontal Construction Joints in Abutments, Piers & Walls

Horizontal construction joints are used to provide a clean, intentional interface between multiple adjacent vertical concrete pours. Three of the more common reasons for utilizing multiple adjacent vertical pours are: the final elevation is not known when the first pour is performed, the finished element contains too much concrete to pour in one day, and the height of wet concrete to construct the element in one pour would fail the forms.

Detail a horizontal construction joint at beam seat elevations. Include this joint in wingwalls. Note that the contractor must take beam profiles and establish the finish grade before placing concrete above this joint. See Figure 5.2.3.1 -1 for the detail if the joint intersects the slope of the wing wall.

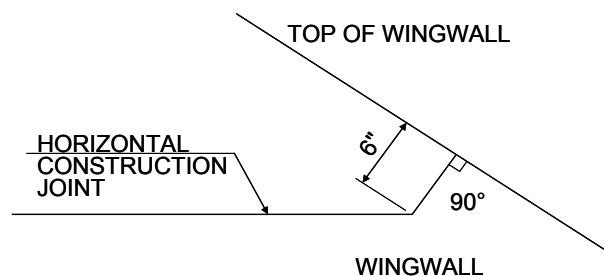

Figure 5.2.2.1 -1 Horizontal construction joint in wing wall.



### 5.2.2.2 Expansion Joints in Abutments, Piers & Walls

An expansion joint is a gap between adjacent concrete elements used to allow the, usually thermally induced, relative movement between the elements without causing damage to the structure. Expansion joints differ from construction and contraction joints because in that no reinforcing steel should pass through an expansion joint.

Detail vertical expansion joints in long, continuous substructures and walls to keep the maximum length of each piece to 90 feet.

### 5.2.2.3 Contraction Joints in Abutments, Piers & Walls

Contraction joints are used in concrete elements to provide an intentional looking place for the concrete to crack due to shrinkage and other effects.

Detail vertical contraction joints in substructures and walls at a maximum of 30 feet intervals measured along the face of the abutment and wing walls.

### 5.2.2.4 Design Software (Conspan)

Be aware that the uniform dead load used in design software is approximate. The calculated dead load does not take into account any dead load from the end blocks or any other solid section that the unit may have. This additional dead load may be considerable and the designer may want to allow for this when designing a bridge, especially with voided box beams.

## 5.2.3 Continuity

When designing integral abutment structures or multiple spans with concrete beams or girders, the designer should design each span of the superstructure as a simple span, and then place the overlay as if the bridge were continuous.

Occasions arise where the designer must use continuity. If this is true, use the live load condition and super dead load condition as load cases for continuity. To calculate reasonable live load moments in the negative moment region, the designer must make a careful assessment of how to model the continuous structure. The structure has no dead load point of contraflexure.

The negative moment region and the overlay are cast-in-place concrete. Use the AASHTO Section 5 to design the overlay and to check flexural cracking in the overlay.

There exists research that recommends the use of positive moment reinforcement over a pier. The NCHRP Report 322 covers this topic in detail.

## 5.2.4 Shrinkage and Temperature Reinforcement

- Reinforce all faces when required to do so according to LRFD Section 5.10.8, except for the top mat of cast-in-place concrete slab bridges and cast-in-place approach slabs.<sup>4</sup>

---

<sup>4</sup> Policy as stated in Structures Engineering Instructions 09-003 (04/20/09). The standard details that have been used prior to LRFD implementation for CIP slab bridges and approach slabs have not included a top mat of reinforcement to control cracking due to the effects of shrinkage and temperature. To date the performance of the slab bridges and approach slabs constructed with out the top mat of reinforcing steel have been satisfactory. In addition, the proximity of a reinforcing steel mat near the top of the deck may cause long term durability problems due to corrosion due to chloride intrusion.

## 5.2.5 Detailing Reinforcing

### 5.2.5.1 Varying Reinforcement Bar Lengths

Avoid detailing reinforcing bars with varying lengths, such as the vertical bars required in sloping wing walls. Detail the bars with the longest length required with the remaining bars cut to fit in the field.

### 5.2.5.2 Reinforcing for Wing wall Corners

Refer to Figure 5.2.7.2 -1 and Figure 5.2.7.2 -2 for the layout of the reinforcing steel in the corner where the abutment meets the wing wall. Use the detail in Figure 5.2.7.2 -2 for all cantilever wingwalls as well.

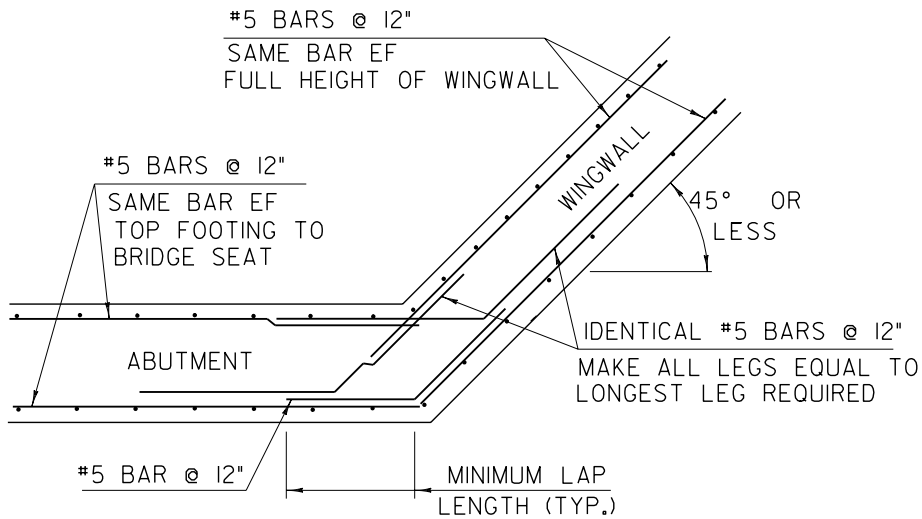

Figure 5.2.7.2 -1 Wing wall corner detail for 45° or under

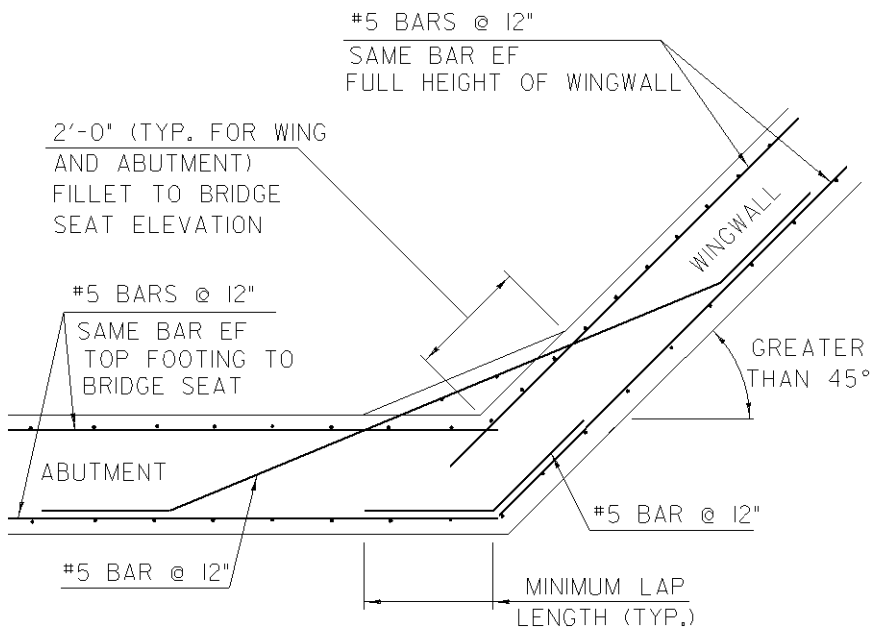

Figure 5.2.7.2 -2 Wing wall corner detail for more than 45° angle

### 5.3 PRESTRESS CONCRETE DETAILS

Most of the details, which the Structures Section developed, show nominal widths for the prestress units. The nominal width is the width at the bottom of the prestress voided slabs and/or boxes. Most details are available in CADD for use on projects. Refer to CADD resources for locations.

#### 5.3.1 Skews

- Form the ends of the voided slab or box beam units on skews up to 45°.
- Voided slabs or box beam units formed with skewed ends greater than 30° will have the acute corner clipped. The designer should determine the clip size. Accepting different clip sizes that the fabricator has shown on shop drawings is acceptable. The clip is to minimize breakage of the corner upon strand release. For expansion ends of box beam decks, specify that the contractor shall fill the clipped void with foam filler prior to the overlay placement. Otherwise, specify using the overlay concrete to fill the void. See Figure 5.3.1 -1.
- Make sure the shop plans show recessed and grouted strands at the ends of the prestress units. This insures the beams will have fully enclosed strands.
- Skew the voids in box beams at the same angle as the beam-ends. Step the voids in voided slabs in order to maintain the minimum clearance from the transverse strands.

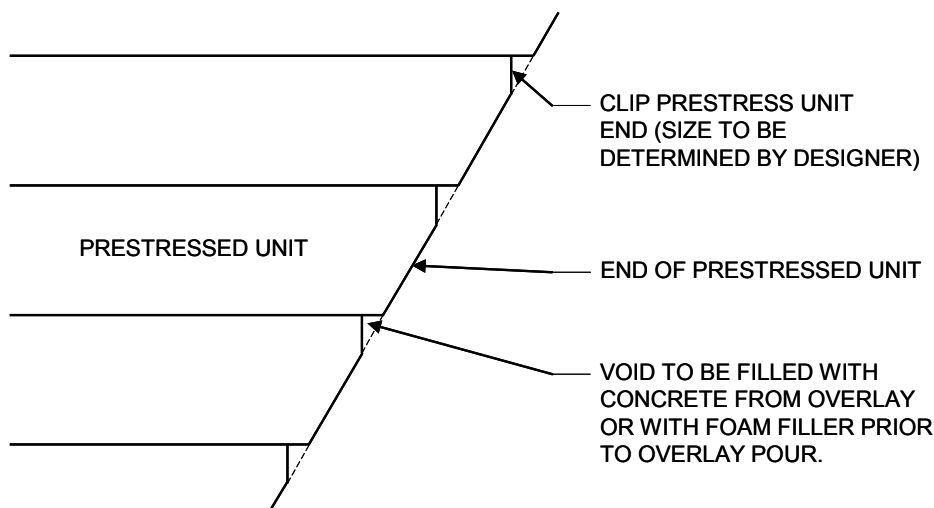

Figure 5.3.1 -1 Clip detail for skews greater than 30°

#### 5.3.2 Surface Treatment

For bare decks without an overlay, provide a sacrificial layer of concrete at the top of the deck units. Prior to longitudinal grooving, the top layer of concrete will be diamond ground to obtain an even finish between beams in order to correct any differential camber.

#### 5.3.3 Preferred Concrete Sections

For concrete superstructures with spans between between 40 and 80 feet the preferred section is the New England Extreme Tee Beam or NEXT Beam. However in some instances this section may not be a viable option. Ideally as a second choice some other non voided concrete section may still be adequate for your project. If neither the NEXT

Beam, nor another non voided structure will work for your site the consideration of Butted Box Beams is acceptable provided it follows the guidance below.

### 5.3.3.1 Site Classifications for Butted Beams

Site Classification I – Private Drives, Class IV roads, recreational trails, roads closed for the winter, dead end class III roads, or other applications receiving little to no de-icing salt and servicing very little traffic are all permitted without having either a membrane and pavement or an overlay. The designer should consider potential for future use of the structure, if more traffic might be anticipated or an un-paved road may become a paved road see Site Classification II.

Site Classification II – Structures on paved roads must have an overlay.

Site Classification III – The interstate and other National Highway System routes are not permitted to have voided structures where inspection of the voids is not possible.

### 5.3.3.2 Structural Overlays

Structural overlays help to distribute the LL force effects between girders and reduce differential deflection that cause cracking in the shear key, effectively extending the life of the structure. For beams that do not utilize an overlay the designer should carefully consider the live load distribution factors used for the design in the event the shear key does fail.

Butted beam decks are a good solution for rapid bridge construction; however, the additional labor and time required for placing an overlay both counters this advantage as well as increases the cost of the project. Consider using an overlay for any of the following reasons on a Site Classification I structure:

- The design requires the additional strength provided by a composite section using a structural overlay.
- Overlays have proven to lock in camber. If the deck profile requires a specific camber, use an overlay to provide more camber control.
- For thinner deck sections such as the 18 inch or thinner voided slab, or solid concrete slabs, an overlay may facilitate the installation of bridge rail.

If an overlay is used, the following shall apply:

- The minimum overlay thickness will be 5 inches.
- The overlay shall be a designed structural section.

### 5.3.4 Shear Keys

Figure 5.3.4 -1 shows the shear key details for prestressed deck beams with a depth of at least 15 inches. Beginning in 2009, all butted voided slab and box beam decks shall use a full depth shear key as shown. PCI-Northeast developed this detail as a way to enhance the longitudinal deck joints as well as unifying details among all states in the Northeast.

LRFD Section 5.14.4.3.2 requires a minimum shear key depth of 7 inches. For beam depth less than 15 inches replace the 4" dimension in the table with the values in Table 5.3.4 -1.

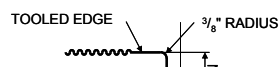

Table 5.3.4 -1 Shear Key Top and Bottom Dimensions

Beam Depth (in)	Dimension (in)
10	1½"
12	2½"
14	3½"

Figure 5.3.4 -1 Full depth shear key detail for voided slabs or box beams at least 15 inch in depth.

According to AASHTO LRFD Section 5.14.4.3.3d, shear keys shall have an average lateral compressive stress of 0.250 ksi. For deep beams, this could require numerous post-tensioning strands to accomplish this feat. Discussions among PCINE members concluded that AASHTO intends this line of code to apply to solid deck slabs or top flanges of segmental units. Voided slabs and box beams tend to direct all compressive forces along the diaphragms, making the deck behave more like a beam-diaphragm grid system.

The number of diaphragms required shall be determined based on a 15' maximum diaphragm spacing with no fewer than 4 diaphragms per span. To determine the post tensioning requirements please see 5.3.6.1 Strands per Sleeve.

### 5.3.5 Grout

Follow VTrans Specification 510.13 for placing grout in shear keys for butted beams. Use a prepackaged grout product that provides high bond strength for grouting of the shear keys. The preferable procedure for mixing grout is by field manual mixing using the grout manufacturer's recommendations. In all situations, require the Contractor to place the grout manually.

### 5.3.6 Transverse Tendons

Use transverse tendons to tie the butted beams together. Show the transverse tendons inserted in a seamless polypropylene sheath. See Figure 5.3.6 -1 and Figure 5.3.6.1 -2. These details show a single strand as a tendon. Modify the details appropriately for multiple strands per tendon.

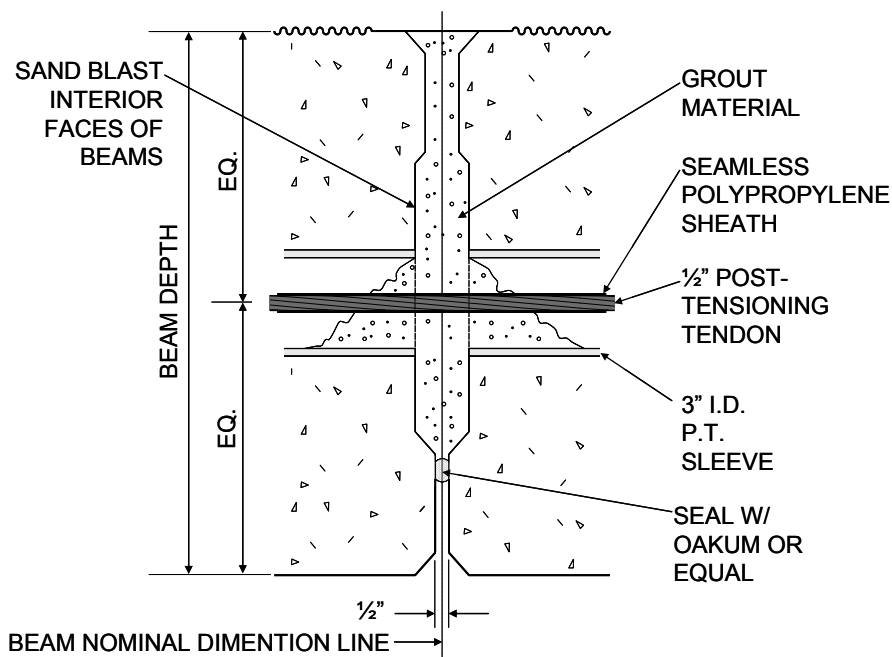

Figure 5.3.6 -1 Longitudinal joint section at transverse tendon.

### 5.3.6.1 Strands per Sleeve

Using the detail shown in Figure 5.3.6.1 -2, the limit of 0.5" diameter strand is three. The limit for 0.6" diameter strand is two. Deck beams 18 inches or shallower shall have one duct per diaphragm with three 0.5" diameter strands. For beams greater than 18 inches in depth two ducts per diaphragm and two 0.6" diameter strands per duct are required. When specifying multiple ducts per diaphragm, make sure they are concentric to the deck beam and are located as far apart, vertically, as practical to maximize the lateral moment resistance. Bridges exceeding 40' in width should consider additional post tensioning to compensate for the losses. Additional strands will require increasing the dimensions of the anchoring plate.

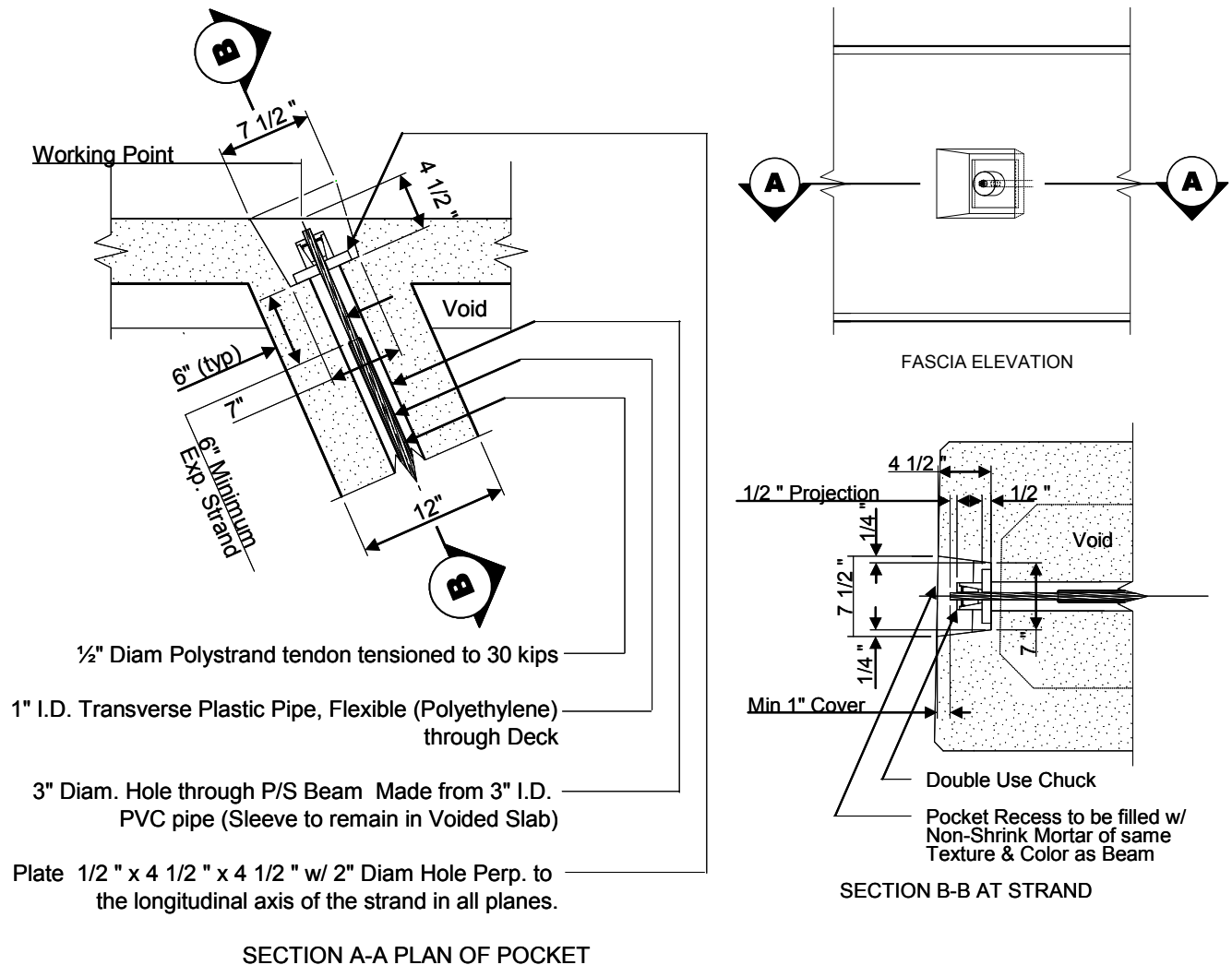

Figure 5.3.6.1 -2 Transverse Post-Tensioning Pocket \*AASHTO M270 Grade 50 steel (M270/M270M, Grade 345 Steel)

### 5.3.6.2 Tendon Pull Requirements

Require the Contractor to pull the tendons symmetrically from the bearings to the midspan. This procedure limits the elastic shortening loss that occurs in the final pull (at midspan) compared with the first pull (at the bearings). Butted beam decks often crack longitudinally along the shear keys at midspan due to thermally induced stresses. These cracks may then be further propagated by additional stresses, such as live load. This phenomena is referred to as “piano keying” when adjacent beams lose the ability to completely transfer the shear stresses, resulting in differential deflections between beams under live load. The additional compressive force at midspan, provided by the post-tensioning should limit this cracking. The designer has the option to require the Contractor to pull the stand a second time to reduce elastic shortening losses; however, research has shown that this is not required<sup>5</sup>.

### 5.3.6.3 Tendon Anchorage Devices

Tendon anchorage devices are required at the ends of each duct. Show or indicate anchorage locations on the drawings. Detailing is unnecessary since the post-tensioning supplier will provide these details in the shop drawings for the post-tensioning system.

### 5.3.6.4 Grout Placement Control

Grout entering the post-tensioning ducts when grouting the shear keys of butted box or voided slab bridge decks is acceptable. The performance of the foam “donuts” used in the past has been poor. They either drop to the bottom of the key, causing a void; shift, allowing concrete to enter the duct; or deform, making threading the post-tensioning strand difficult.

## 5.3.7 Butted Deck Beam Framing Plan

Typically, a prestressed deck beam bridge consists of butted voided slab or box beams with or without an overlay. When detailing the deck plan consider the following:

- Transverse tendons shall be covered by seamless polypropylene sheath [with corrosion inhibitor grease between sheath and strand] for the length of strand, except at anchorage locations, ties shall be tensioned to either 33 kips for each 0.5 inch diameter strands and 47 kips for each 0.6 inch diameter strand.
- Post-tensioning of the transverse tendons will follow the construction guidelines detailed in Section 5.6.2 in this manual.
- Specify beam type. Use only nominal beam widths when specifying the beam width (W) and calculating total width (Total W). Make every attempt to use the widest section available and be consistent. For deck-beams, use 48 inch wide sections. If the bridge geometry is tight, using a single 36 inch (915 mm) section is acceptable. Another option is to bring in the outer fascias of the exterior beams, equally by the required dimension. The precaster can cast the latter in the same bed with some modifications as the other beams, thus keeping the cost down.
- The price of a precast unit depends on the time and labor to ready the bed, assemble the reinforcing and run the strands; time spent in the casting bed curing; time to detension and move out to the yard. These costs are relatively static and are not dependent on the section width. Concrete and reinforcing steel costs are relatively minor. The per foot cost of casting a 36-inch section can be nearly the same as casting a 48-inch section. This results with a 36-inch section carrying a higher per square foot cost than a 48-inch section. The cost of the bridge will be lower with fewer wider deck beam sections, even if the width of the bridge increases slightly. Framing plan shall be drawn full length without breaks, and to scale, on the construction plans. Show all internal voids and transverse ties.

---

<sup>5</sup> El-Remaly, Ahmed, et al, 1996, “Transverse Design of Adjacent Precast Prestressed Concrete Box Girder Bridges”, PCI Journal, July-August 1996, pp 96-113

- If torsional load in fascia beams (due to sidewalk overhang or utilities), is excessive, increase the number of strands and/or post-tensioning tendons and adjust transverse tie locations as required.
- The designer shall verify that no conflict exists with the prestressing strands the transverse tendons, the anchor bolts, and the rail anchoring system.
- Ends of voids shall be parallel to the face of the abutment.

### 5.3.8 End Reinforcing Details

Voided Slabs require specific reinforcing details at the end of the beam and at each transverse tendon location. At the transverse tendon location, this reinforcing is required on both sides of the voids to handle any bending stresses that cross the voids. Examples of end block details are shown in Figure 5.3.9 -1.

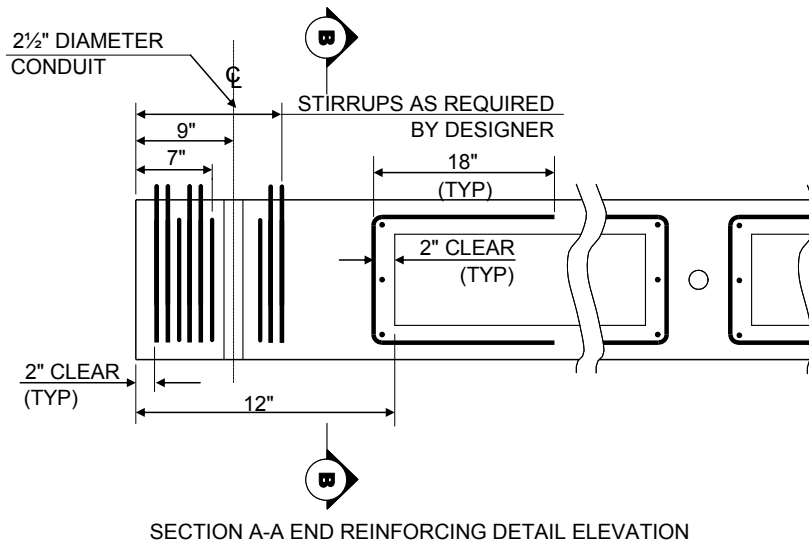
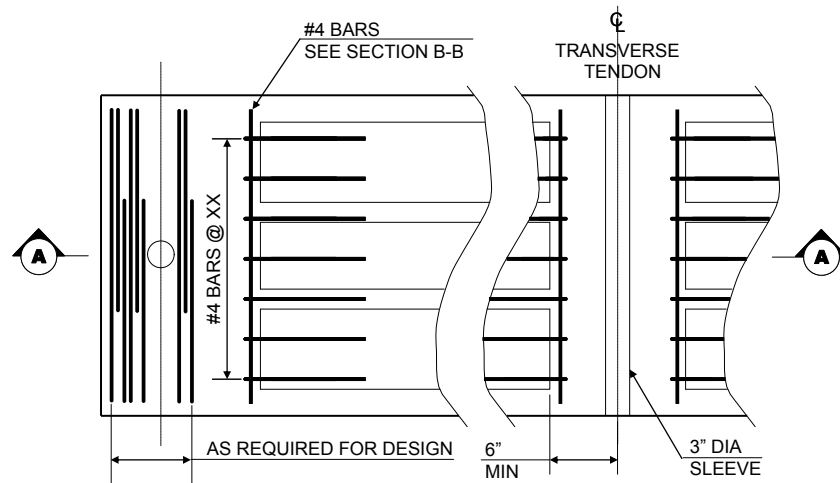

SECTION A-A END REINFORCING DETAIL ELEVATION



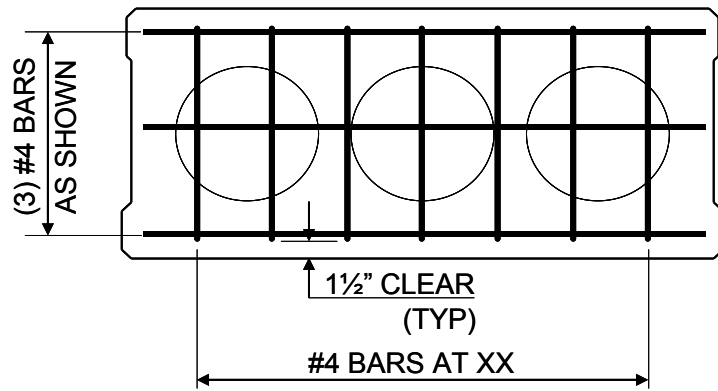

SECTION B – B END REINFORCING SECTION

Figure 5.3.9 -1 End reinforcing detail.

### 5.3.9 Void Drains

All voided slabs and box beams require void drains. This does not require a detail; but rather add a note to the project plans. The note should state that the void drains comprise of nonferrous,  $\frac{3}{4}$  inch (20 mm) diameter drain material. Specify that the Contractor clean the drains after erection.

### 5.3.10 Strand Patterns

The Structures Section has developed strand patterns for all sizes of voided slabs and box beams. These are not cells, but design details that the designer can use on a project-by-project basis. The designer shall place strands as required within the confines of the pattern. The stirrup patterns will stay the same. However, the quantity and/or size of the stirrups may be different. The designer may design the number of strands for each row, but may not alter the clearances detailed in the Figures. This is to provide consistency among designers in strand patterns and clearances.

- The first row of the strands has been set at  $2\frac{3}{4}$ " from the bottom of the unit. The designer should not deviate from this distance.
- Designers will continue to have the option of designing debonded strands or adding reinforcing steel in the top portion of the units.
- Stirrups will be Level II or Level III reinforcing depending on the level of corrosion resistance required for the superstructure.

## 5.4 CONCRETE BRIDGE END DETAILS

Refer to Section 2.5.1 for assistance in selecting a bridge end detail. The bridge end details in Section 5.7 provide additional details for the specific bridge deck or beam type.

### 5.4.1 Anchor Bolt Detail

Anchor the ends of beams to the abutments or piers using anchor bolts as shown in Figure 5.4.1 -1.

Make sure anchor bolts, steel plates and nuts are included as part of item 510.21 "Prestressed Concrete Box Beams".

Specify all Anchor Bolts and Nuts as AASHTO M164M and require them to be zinc coated. Specify all washers shall be AASHTO M270M Grade 345 and require them to be galvanized using AASHTO M111M.

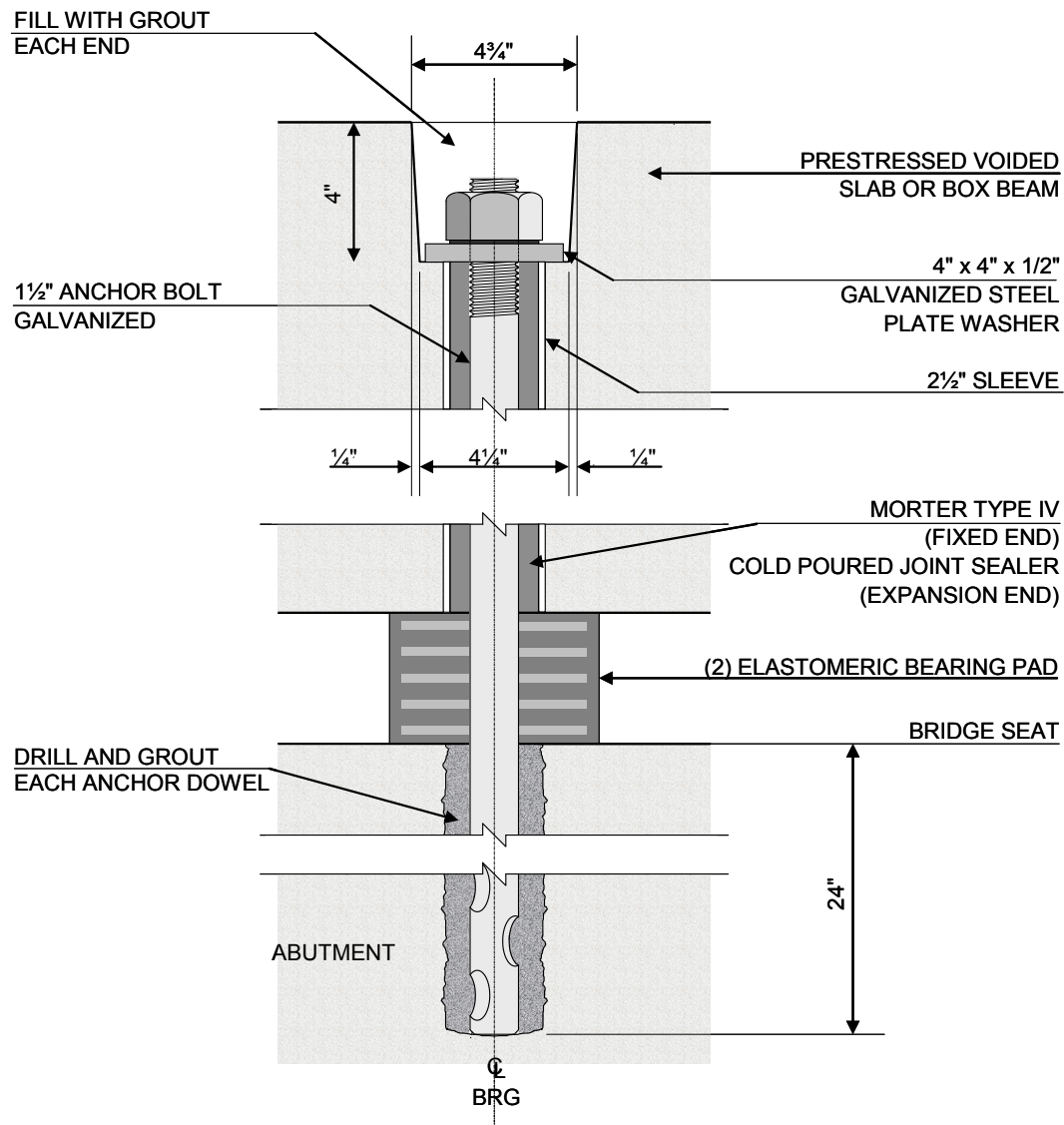

Figure 5.4.1 -1 Prestress Beam Anchor Detail

## 5.4.2 Waterstop

Use the waterstop to seal the horizontal joints or gaps often found in bridge end details. Separate concrete placements create such joints. Setting prestressed concrete beams on bearings creates a gap between the beam and the bridge seat. The waterstop as shown in Figure 5.4.2 -1 have longitudinal tabs that embed into concrete when placed. When using with prestressed concrete beams, clip off the tabs that would otherwise be set against the beam so the waterstop can be fully adhered to the beam end.

Include P.V.C. waterstop as part of the payment for the unit bid price for the adjacent cast in place concrete. The engineer may allow alternative waterstop configurations.

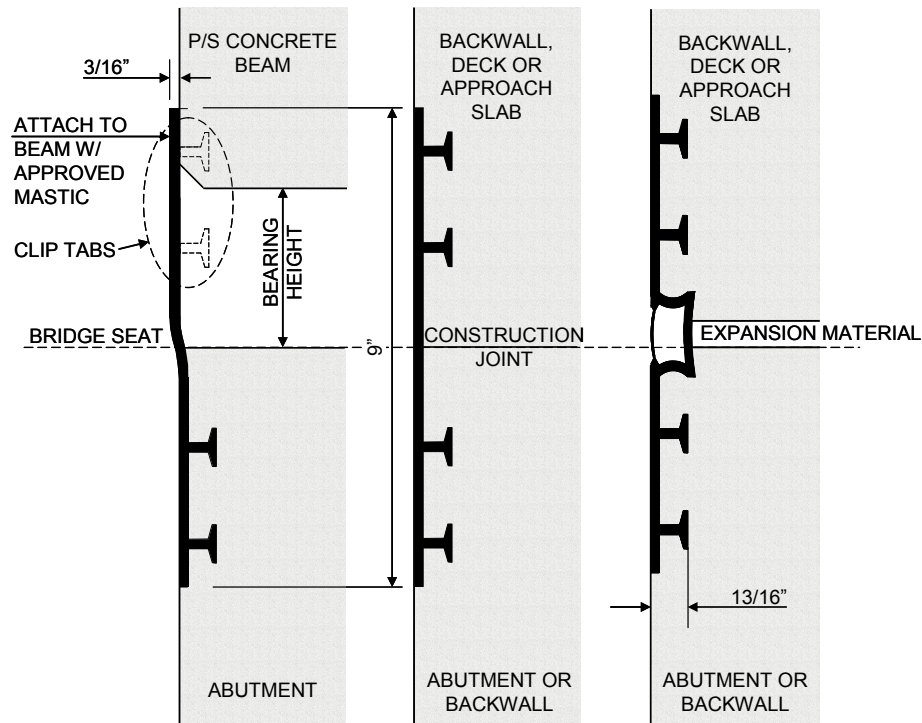

Figure 5.4.2 -1 Waterstop detail.

### 5.4.3 Negative Moment Reinforcement

End details such as those required for integral abutment bridges require negative moment connectivity between the deck and the abutment. Use a reinforcing configuration shown in Figure 5.4.3 -1 to make such a connection.

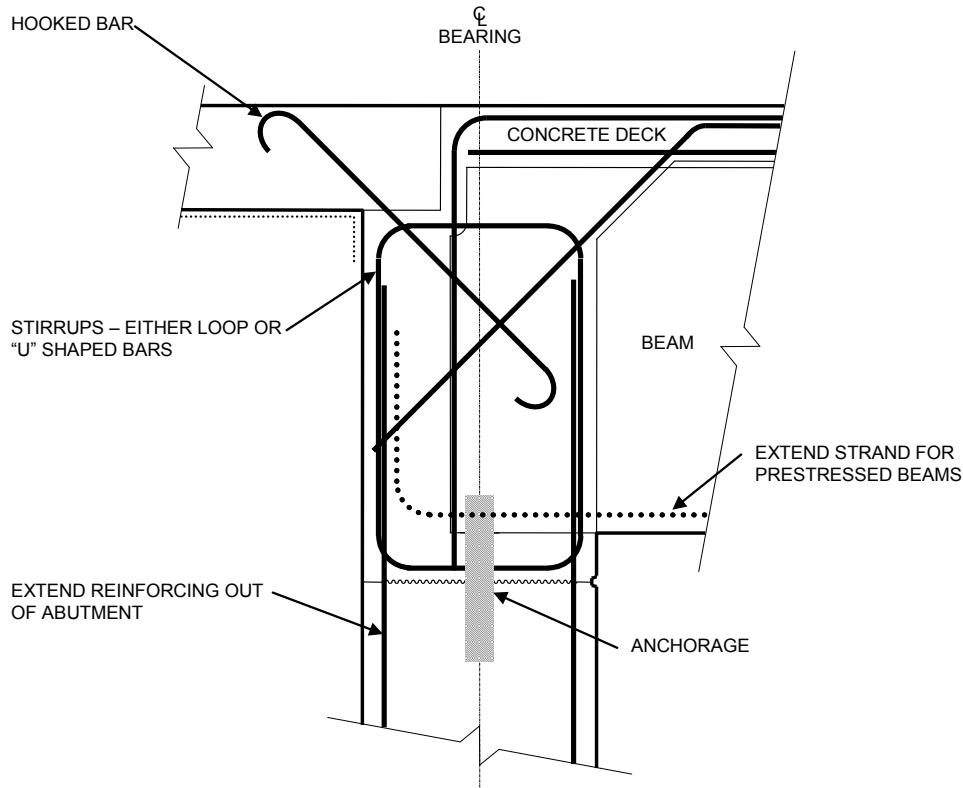

Figure 5.4.3 -1 Negative Moment Reinforcement.

## 5.5 DEVELOPMENT AND SPLICES OF REINFORCEMENT

### 5.5.1 Development of Reinforcement

Critical sections for development of reinforcement are at points of maximum stress and at points where adjacent reinforcement terminates or bends.

### 5.5.2 Splices of Bar Reinforcement

- Min splice length shall be 12 inches.
- Avoid splicing epoxy coated and conventional black reinforcing steel if possible. If necessary, splice the bars outside of the concrete requiring epoxy coated rebar.

### 5.5.3 Commonly Used Splices Lengths

Use Table 5.5.3 -1 to determine the splice class. Table 5.5.3 -2 and Table 5.5.3 -3 provides commonly used tension and compression splices of deformed bars for Class B Concrete for the various splice classes. For other concrete classes refer to LRFD Section 5.11.2.

Table 5.5.3 -1 Splice Class Criteria for tension lap splices

As provided / As required	Maximum percentage of area of steel, spliced within the lap length		
	50	75	100
2 or greater	Class A	Class A	Class B
less than 2	Class B	Class C	Class C

Table 5.5.3 -2 Basic Development and Splice Lengths  
for Class B Concrete (Tension) ( $f'c = 3.5$  ksi)

Bar Size	Class A Splice	Class B Splice	Class C Splice
	$l_{db}$	$1.3 l_{db}$	$1.7 l_{db}$
3	12"	2'- 0"	2'- 0"
4	12"	2'- 0"	2'- 0"
5	15"	2'- 0"	2'- 2"
6	18"	2'- 0"	2'- 7"
7	25"	2'- 9"	3'- 7"
8	32"	3'- 6"	4'- 7"
9	41"	4'- 6"	5'-10"
10	51"	5'- 7"	7'- 3"
11	63"	6'-10"	9'- 0"

LRFD Section 5.11.2.1

Table 5.5.3 -3 Basic Development and Splice Lengths  
for Class B Concrete (Compression) ( $f'c = 3.5$  ksi)

Bar Size	Class A Splice	Class B Splice	Class C Splice
	$l_{db}$	$1.3 l_{db}$	$1.7 l_{db}$
3	8"	2'- 0"	2'- 0"
4	11"	2'- 0"	2'- 0"
5	13"	2'- 0"	2'- 0"
6	16"	2'- 0"	2'- 2"
7	18"	2'- 0"	2'- 7"
8	21"	2'- 3"	2'-11"
9	23"	2'- 6"	3'- 3"
10	26"	2'-10"	3'- 8"
11	29"	3'- 2"	4'- 1"

LRFD Section 5.11.2.2

- $f'c = 3.5$  ksi
- $f_y = 60$  ksi
- $l_{db}$  = Basic development length. See LRFD Section 5.11.2.
- Calculate Splice lengths for  $f'c = 4.0$  ksi concrete. These lengths are slightly less than lengths for  $f'c = 3.5$  ksi concrete.
- Calculate Splice Lengths for Top Horizontal reinforcement above more than 12" of fresh cast concrete. The modification factor is 1.4.

### 5.5.4 Splice modifiers

- LRFD Section 5.11.2 contains several factors that either will make the splice length longer or shorter. Common factors used in the Agency are:
  - For top steel of footings with at least 12 inches (300 mm) of concrete cast below:
 
$$C_d = 1.4$$
  - For epoxy-coated bars with cover less than  $3d_b$  or with clear spacing between bars less than  $6d_b$ :
 
$$C_e = 1.5$$
  - For all other epoxy coated steel not covered above:
 
$$C_e = 1.2$$
- The product of  $C_d$  and  $C_e$  need not be greater than 1.7.

$$CdCe \leq 1.7$$

- If the spacing (s) is 6 inches or more, the designer may choose to apply a factor of 0.8 to the development length.

### 5.5.5 Common Splices

Generally, group splices in the three categories described in this section. In all cases, avoid splicing bars larger than #11.

#### 5.5.5.1 Category 1

A splice category that excludes a physical splice, however, alternate bars terminate as shown in Figure 5.5.5 -1.

1. Maximum of d, 15db or 5% of stem height
2. Splice length shall be at least ldb for bar "B".
3. Splice length shall be at least ldb for bar "A"

#### 5.5.5.2 Category 2

A splice category 2 is where the bar-splice is at the top of footing, See Figure 5.5.5 -2.

1. Where both bars are the same, the splice length shall be 1.7ldb or greater. Where bar "A" is larger than bar "B", use the criteria for the category 3 splice.

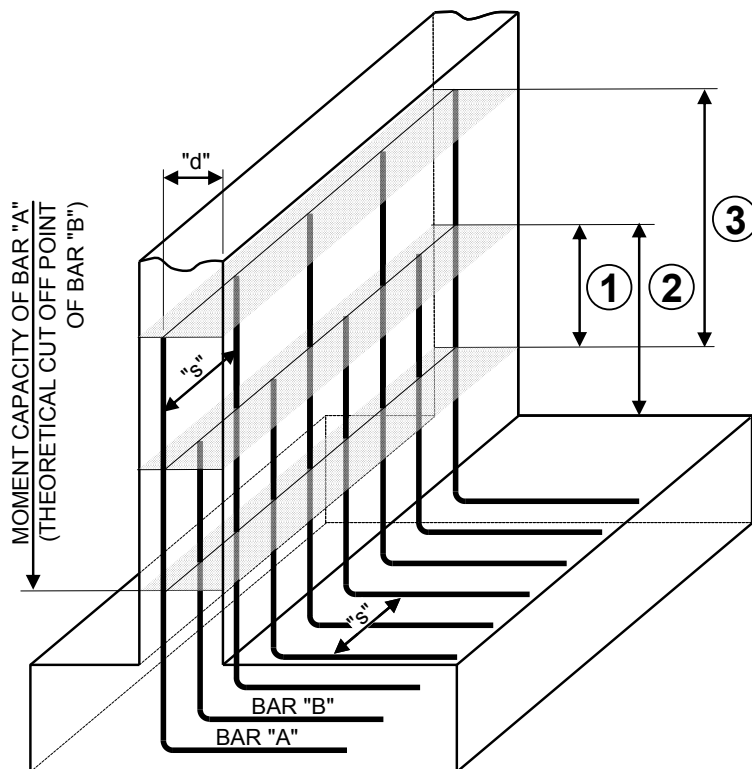

Figure 5.5.5 -1 Cat. 1: Alternate Bars Terminated

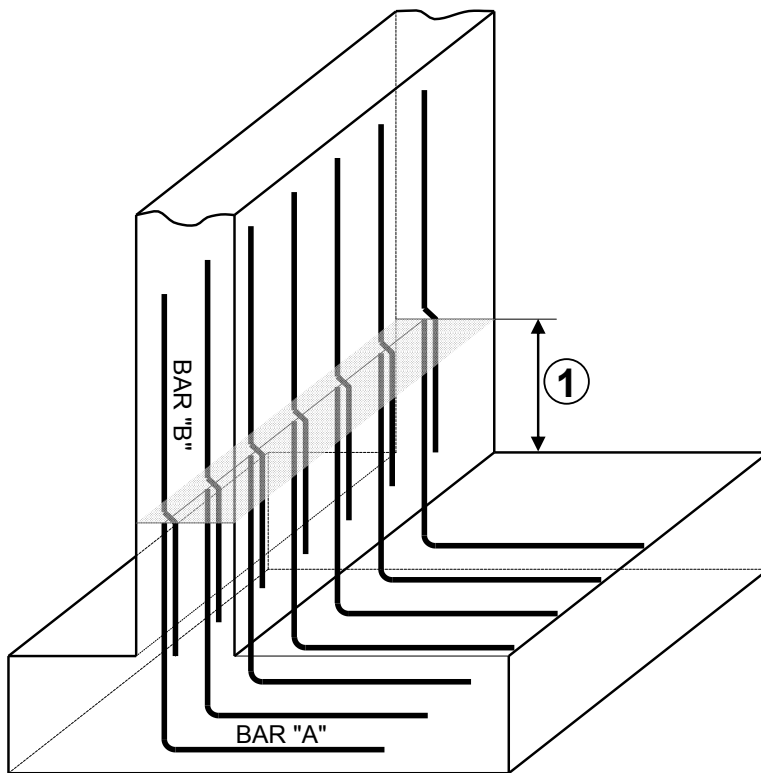

Figure 5.5.5 -2 Cat. 2: Bars Spliced at the Footing

### 5.5.5.3 Category 3

A splice category 3 is where the bar-splice and bar size change occurs at the moment capacity of the smaller bar, See Figure 5.5.5 -3.

1. Maximum of  $d$ ,  $15d_b$  or 5% of stem height
2. Splice length shall be at least  $1.3ldb$  of bar "B" (for Class B splice - Table 5.5.3 -1) or shall be at least  $1.7ldb$  of bar "B" (for Class C splice - Table 5.5.3 -1)
3. Splice length shall be at least  $ldb$  of bar "A".

Where:

- $d$  = Effective depth
- $d_b$  = Nominal bar diameter
- $ldb$  = basic development length
- $s$  = spacing between bars being developed

Refer to the Building Code Requirements for Reinforced Concrete ACI 318R-05 (ACI 318RM- 05) Commentary for another source of information.

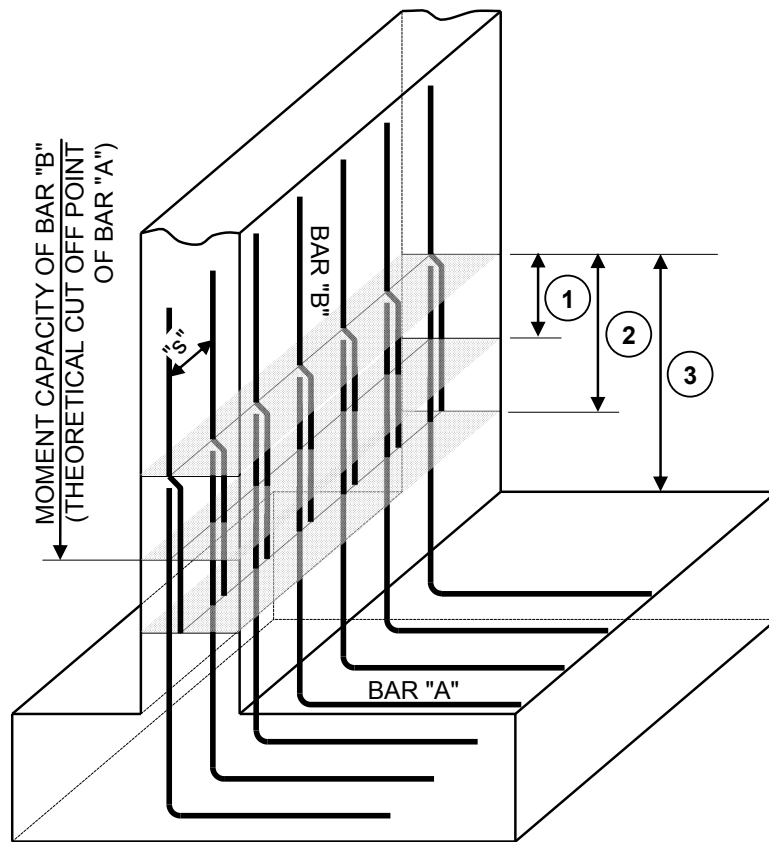

Figure 5.5.5 -3 Cat. 3: Bars Spliced above the Footing

## 5.6 CONSTRUCTION

### 5.6.1 Deck Concrete Placement Sequence

#### 5.6.1.1 Simple Spans

For single span decks, place concrete in one placement, beginning at the low end and proceeding to the high end.

#### 5.6.1.2 Continuous Spans

Establish a deck concrete placement sequence for a continuous span structure using the following criteria:

- Provide joints at the approximate location of the dead load inflections.
- Place positive moment regions prior to the negative moment regions.

#### 5.6.1.3 Three Span Continuous Cantilevers

For three span continuous cantilevers designed with a specific cantilever end dead load due to end wall items and wing walls, place end loadings at least 48 hours prior to any deck pours.

#### 5.6.1.4 Deck Construction Joint Details

Show transverse deck construction joint details on the plans.



### **5.6.1.5 Curbs and Sidewalks**

Place curbs and sidewalks in alternating 15 foot length sections. If possible, the designer should avoid having curb and sidewalk steel extending from prestress units. Instead, whenever possible, incorporate the curb or sidewalk steel into the overlay. This will eliminate problems or concerns regarding the curb steel in the flares at the ends.

### **5.6.1.6 Deck Finish**

All non-paved concrete decks should receive a broom finish and longitudinal deck grooving.

## **5.6.2 Sequence of Construction for Prestressed Voided Slabs and Box Beams**

The following is a suggested sequence of construction and is included to inform the designer of how these units go together. This sequence, or parts of it, may be included in the plans to assist the contractor and resident engineer.

### **5.6.2.1 Layout Working Lines**

- Lay out working lines for the bridge's entire width on the beam seat. Measure all working lines from a common working point.
- Base the working lines on the nominal beam widths.

### **5.6.2.2 Verify Beam Seat Elevations**

- Take elevations at beam seats.
- If seats are high, grind to correct elevations.
- If seats are low, add shims.
- Locate and drill one 3 inch diameter hole at each anchor bolt location.
- Install bearings.

### **5.6.2.3 Erect Beams**

- Verify that the Precaster sandblasted the shear key fascias of the beams.
- Prior to erecting the beams, power-wash the fascias with water to remove dust and other debris.
- Place beams to fit within the working lines.
- As work progresses, install hardwood wedges between adjacent beams to maintain proper joint opening with a minimum of one wedge at each lateral tie.
- Place Anchor bolts.
- Grout anchor bolts into the substructure.

### **5.6.2.4 Install Oakum or Equivalent Joint Filler (backer rod)**

- Fit filler material at the bottom of the shear key as shown on the Plans.

### **5.6.2.5 Install Transverse Post-tensioning Tendons**

- A seamless polypropylene sheath shall completely encase the transverse post tensioning tendons with corrosion inhibitor grease between sheath and strand.

- Slide the transverse post tensioning tendons through ducts.
- Verify that hardwood wedges are in place as required to prevent slippage of beams.
- Using calibrated jack, post-tension tendons to approximately 5 kips to remove sag in the tie and to seat the chuck.
- For stage construction, protect the second stage ducts at the joints, with the second stage strand in place, or Styrofoam over the duct opening.

#### **5.6.2.6 Grout Shear Keys**

- Clean joint with an oil free air-blast immediately before grout placement. Then verify that the backer rod is still in place.
- Additional joint preparation and grout placement shall be per manufacturer's recommendations.
- Carefully rod joints to eliminate any possibility of voids.

#### **5.6.2.7 Post-Tension Transverse Tendons**

- Grout shall attain a minimum compressive strength of 1500 psi, based on the manufacturer's recommendations, prior to stressing.
- Using a calibrated jack operated by qualified personnel, post-tension tendons to 33 kips for each 0.5" diameter strands or 47 kips for each 0.6" diameter strand. Begin with the tendons at each end and then work symmetrically towards the midspan from each end. This will provide the maximum compressive force between deck beams.

#### **5.6.2.8 End Details**

- Grout anchor bolts into the sleeves in the prestressed units at the fixed ends. Before the grout cures, place the washer plate, and install the nut on top and tighten.
- Place the cold poured joint sealer in the sleeves in the prestressed units at the expansion ends. Place the washer plate and install the nut on top. Hand-tighten and then loosen ½ turn.
- Grout over the nut and bolt in the anchor bolt block outs on the fixed ends. Fill the anchor bolt block outs on the expansion ends with cold poured joint sealer.

#### **5.6.2.9 Finish Work**

- Remove wedges, and patch deck and fascia beams at transverse ties.
- If required, place an overlay
- For End Detail that use backwalls, place the back wall first and then place an overlay.
- Place an approach slab.

#### **5.6.2.10 Construction Joints**

The designer should place a construction joint at the bridge seat on the substructures for their project. In addition, include the following note to the project plans: "Concrete will not be placed above the bridge seat elevations until the Prestress units have been set."

## 5.7 CONCRETE BRIDGE END DETAILS

### 5.7.1 Concrete Bridge End Details - Type A

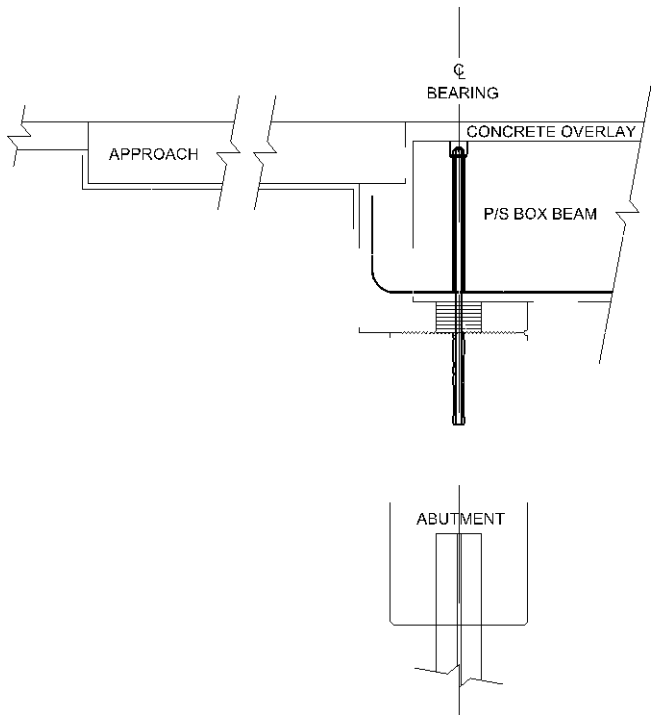

Figure 5.7.1 -1 Box Beam Type A Bridge End Detail

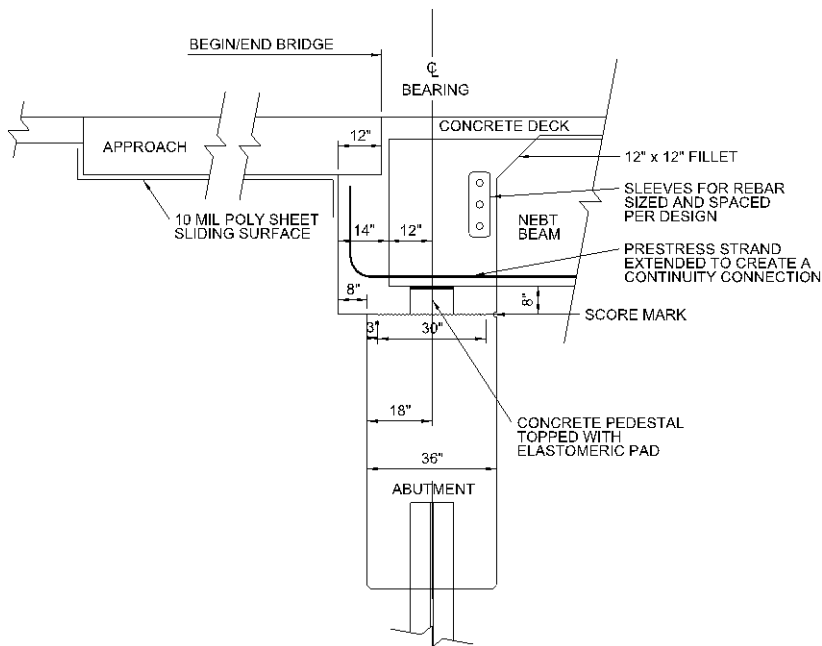

Figure 5.7.1 -2 North East Bulb Tee (NEBT) Type A Bridge End Detail

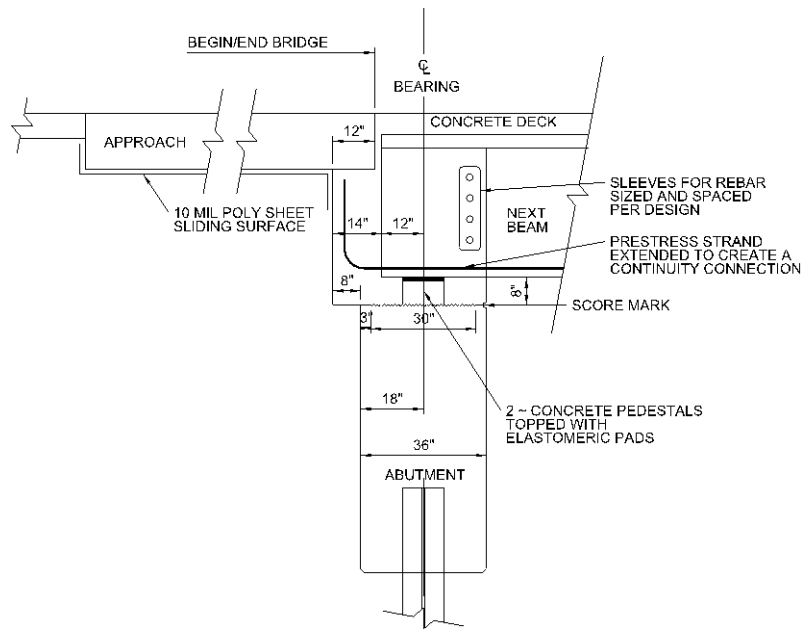

Figure 5.7.1 -3 North East Extreme Tee (NEXT) Type A Bridge End Detail

### 5.7.2 Concrete Bridge End Details - Type B

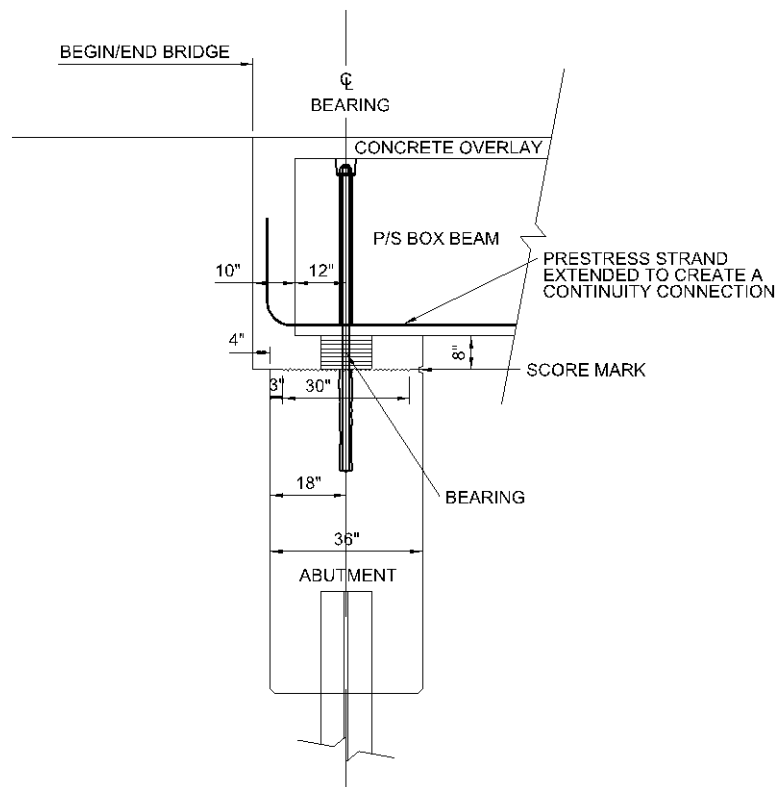

Figure 5.7.2 -1 Box Beam Type B Bridge End Detail

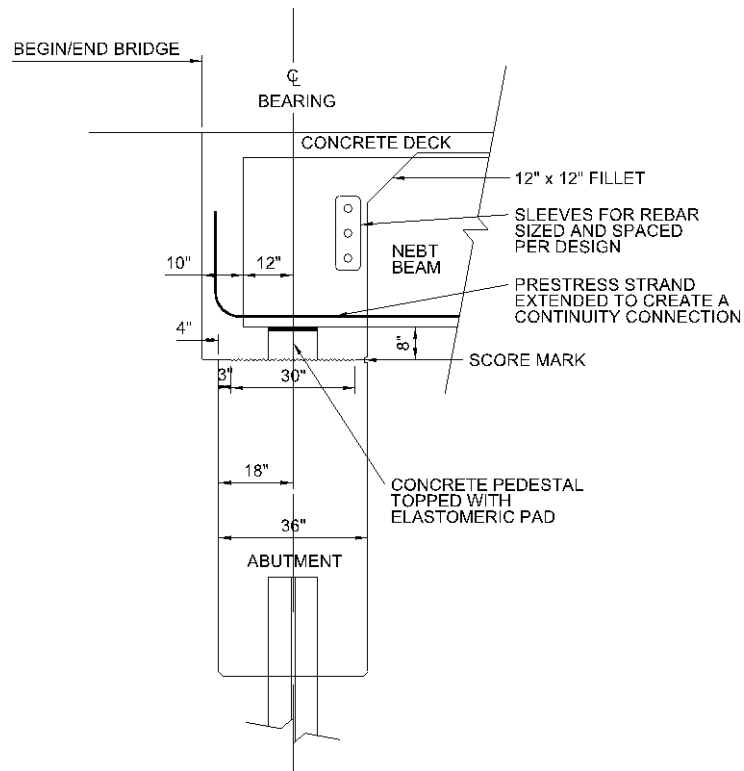

Figure 5.7.2 -2 North East Bulb Tee (NEBT) Type B Bridge End Detail

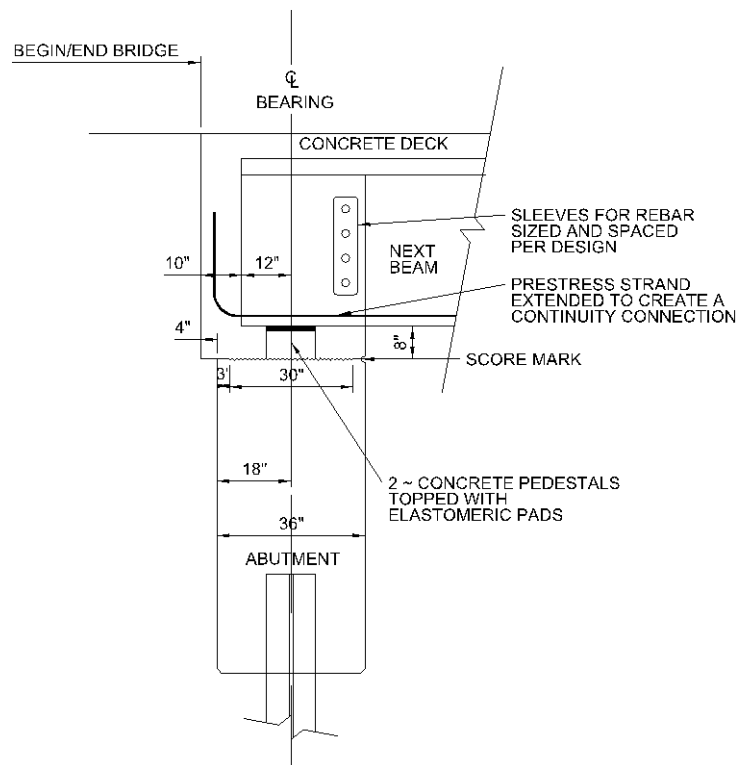

Figure 5.7.2 -3 North East Extreme Tee (NEXT) Type B Bridge End Detail

### 5.7.3 Concrete Bridge End Details - Type C

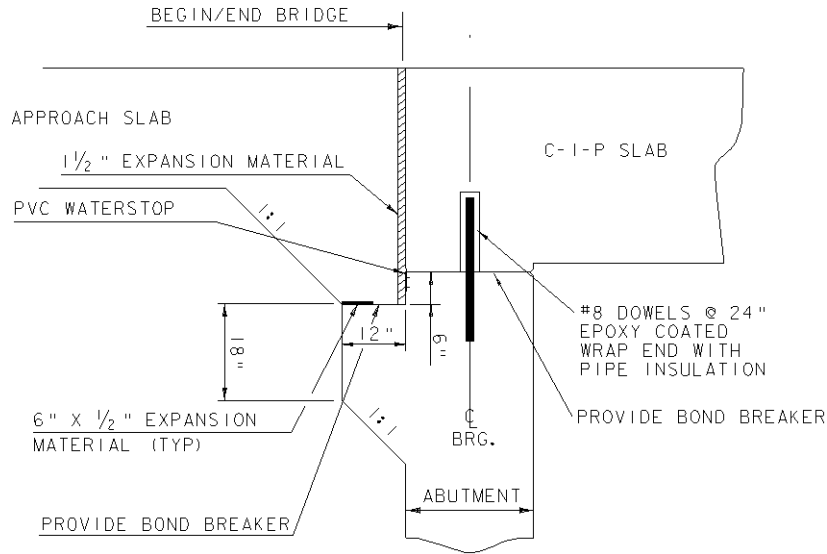

Figure 5.7.3 -1 Cast-in-Place Concrete Slab Type C Bridge End Detail

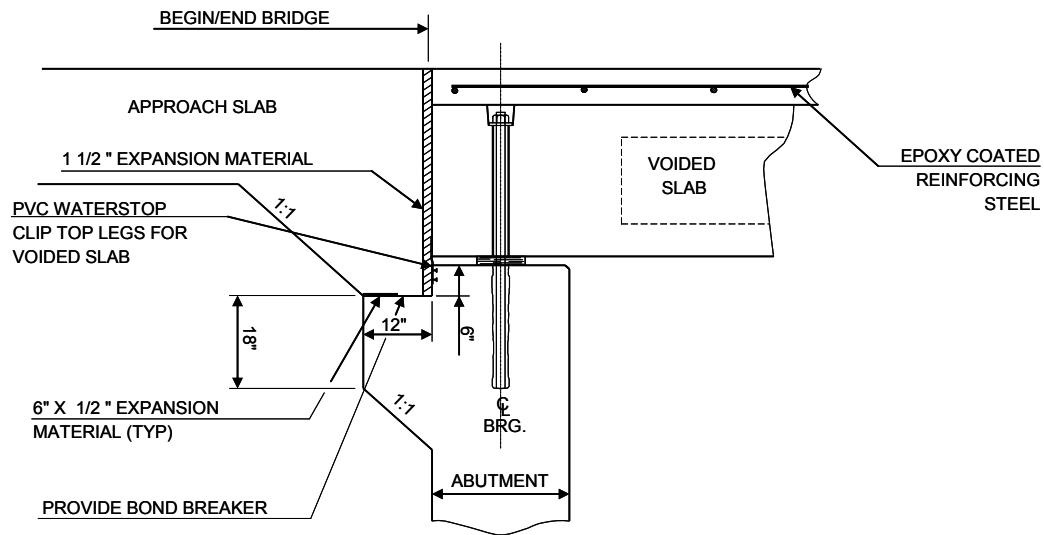

Figure 5.7.3 -2 Voided Slab Type C Bridge End Detail

### 5.7.4 Concrete Bridge End Details - Type D

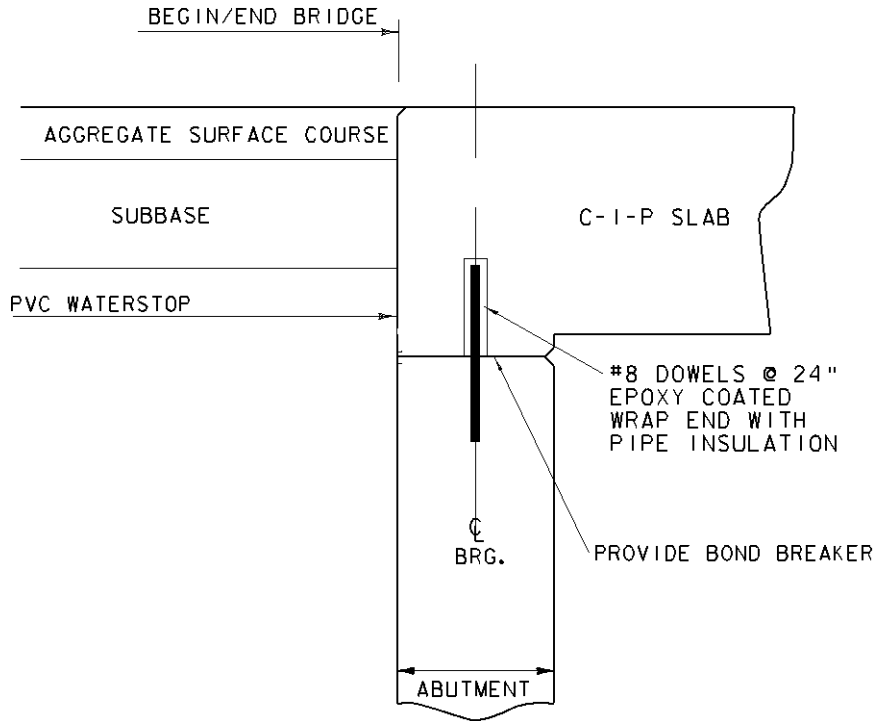

Figure 5.7.4 -1 Cast-in-Place Concrete Slab Type D Bridge End Detail

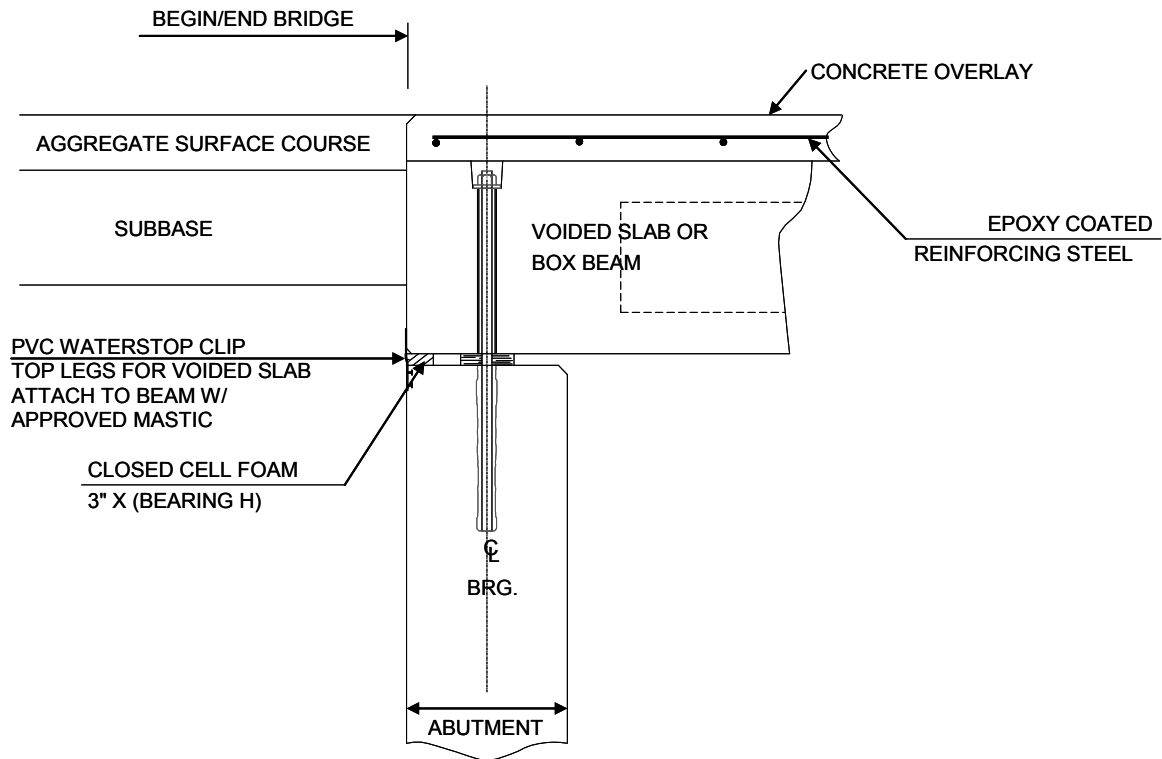

Figure 5.7.4 -2 Voided Slab and Box Beam Type D Bridge End Detail

### 5.7.5 Concrete Bridge End Details - Type E

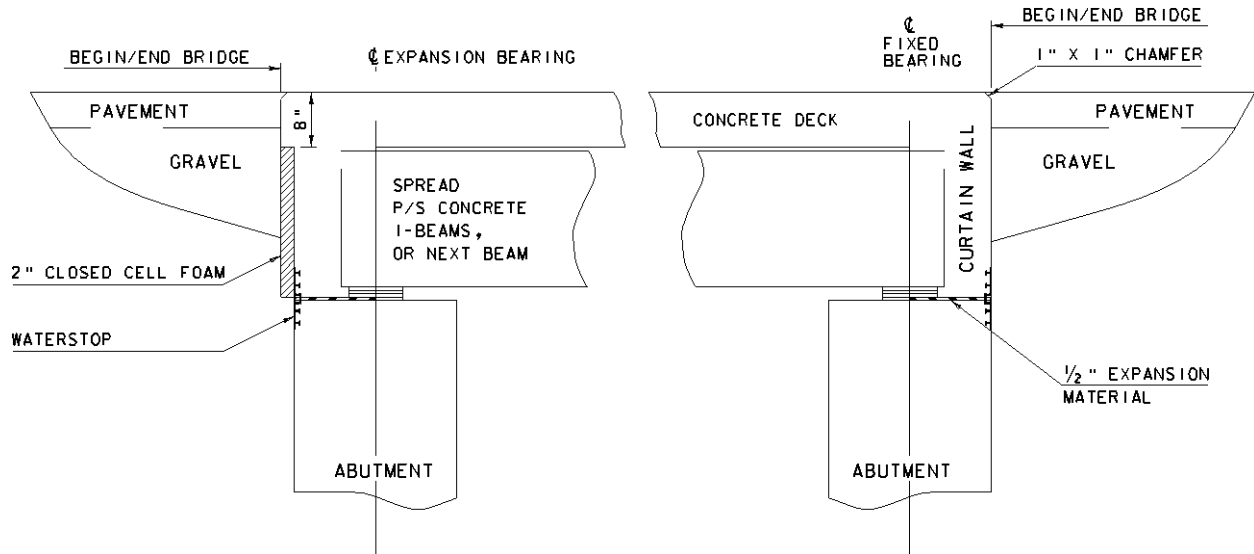

Figure 5.7.5 -1 North East Bulb Tee (NEBT) Type E Bridge End Detail

### 5.7.6 Concrete Bridge End Details - Type F

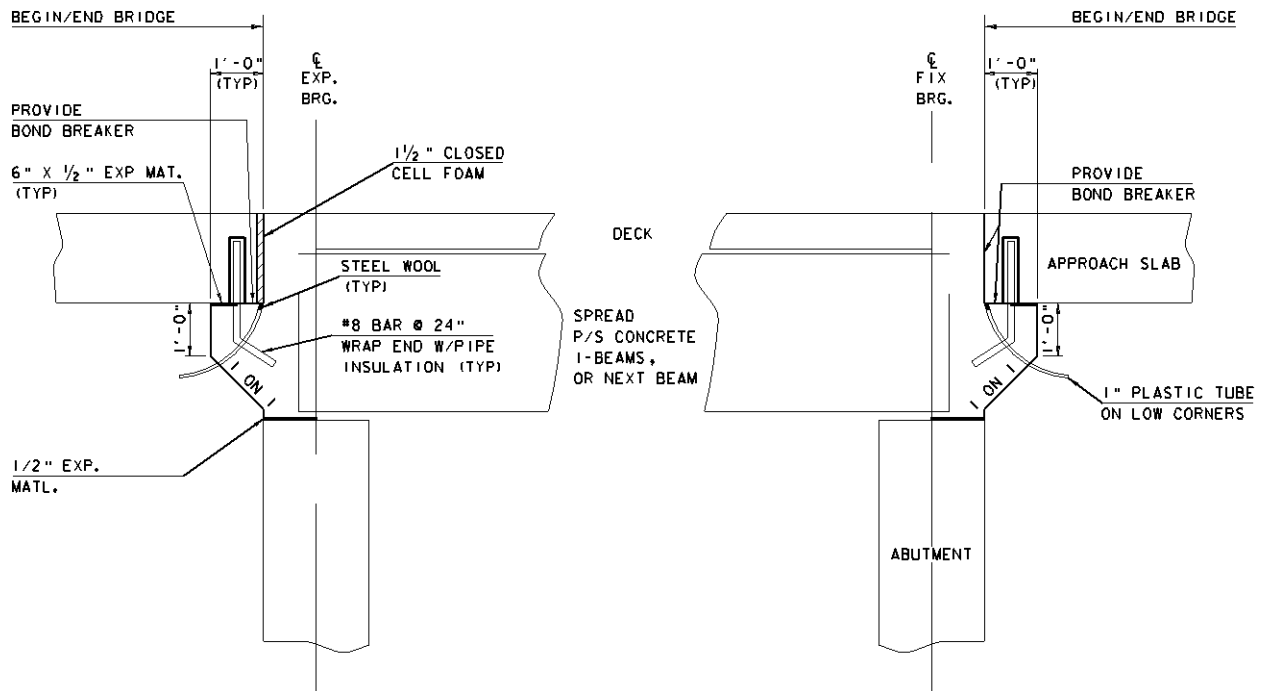

Figure 5.7.6 -1 North East Bulb Tee (NEBT) Type F Bridge End Detail



### 5.7.7 Concrete Bridge End Details - Type G

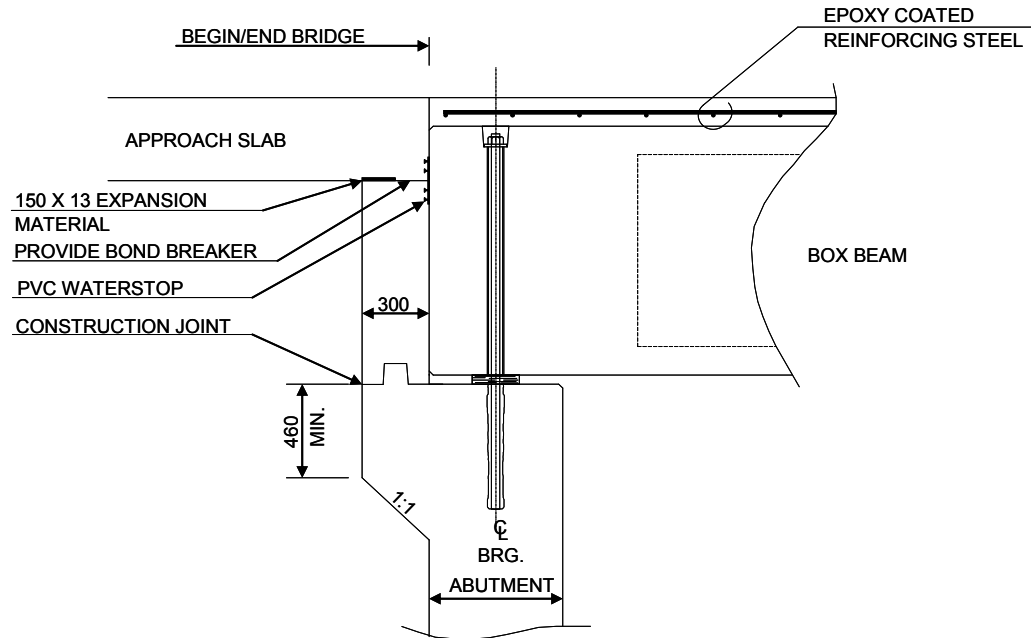

Figure 5.7.7-1 Box Beam Type G Bridge End Detail

### 5.7.8 Concrete Bridge End Details - Type H

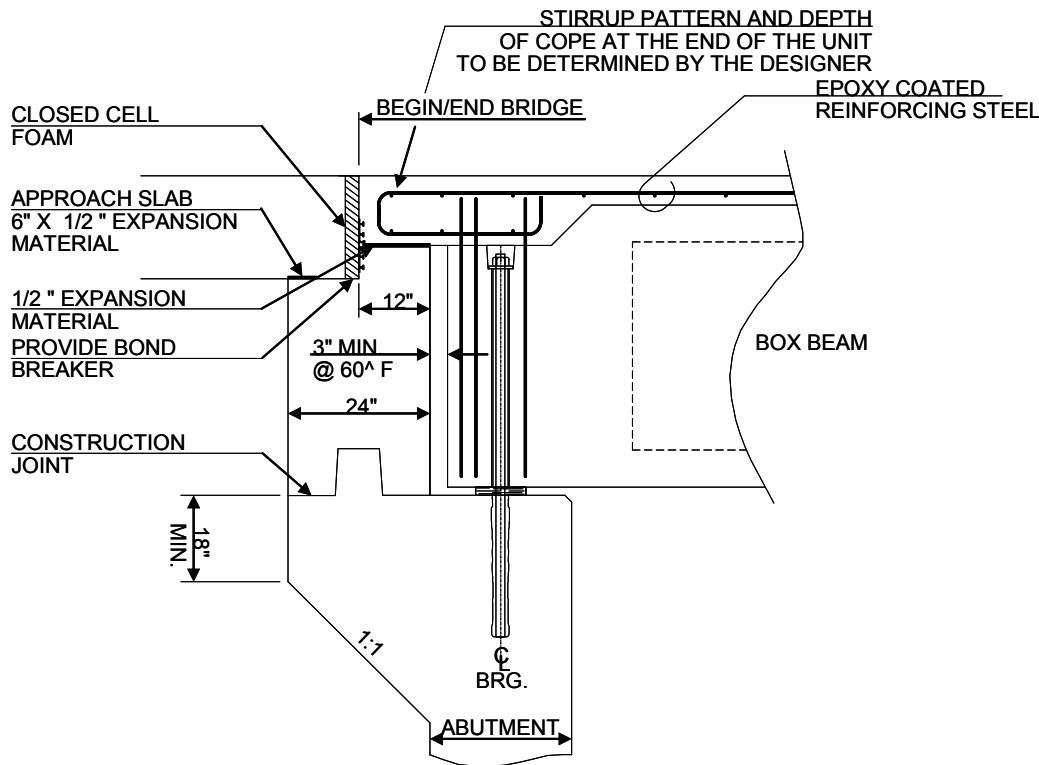

Figure 5.7.8 -1 Box Beam Type H Bridge End Detail

### 5.7.9 Concrete Bridge End Details - Type I

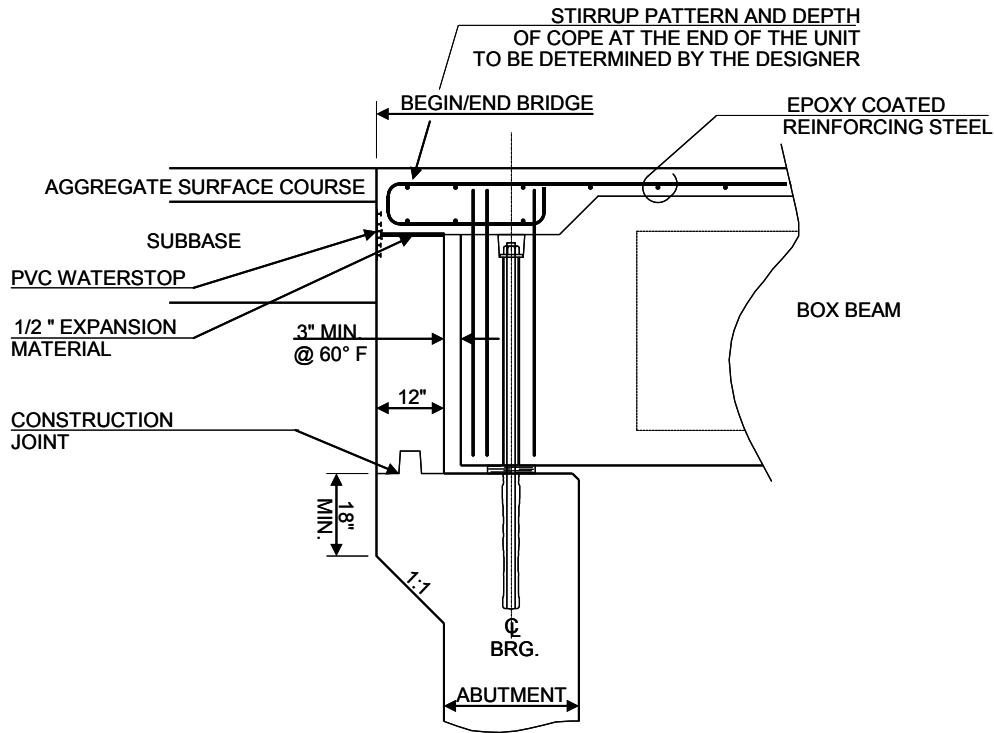

Figure 5.7.9 -1 Box Beam Type I Bridge End Detail



## SECTION 6: STEEL STRUCTURES

### 6.1 GENERAL DESIGN

Refer to AASHTO LRFD Section 6 “Steel Structures” and use the Load and Resistance Factor Design (LRFD) concept for all new structural steel design.

Refer to AASHTO Section 1.3 for information regarding bridge rehabilitation

Refer to AASHTO Section 6.15 for the design of steel foundation piles.

Refer to joint document [G12.1 “Guidelines for Constructibility”](#) from AASHTO and National Steel Bridge Alliance (NSBA) for recommendations (from a group of design engineers and fabricators) on topics such as flange sizing, cross frames, stiffeners, bolts, splices and etc. AASHTO/NSBA [G1.4 “Guidelines for Design Details”](#) is also a valuable reference. These documents and other AISC and AASHTO/NSBA collaboration standards can be found at <http://www.aisc.org/contentNSBA.aspx?id=20130>.

### 6.2 MATERIALS

#### 6.2.1 Structural Steel

In most cases AASHTO M270 (Grade 50) steel is used for design of steel components. High Performance Steel may be used where warranted. (See Section 6.2.1.2 ) The following material properties are also used in the design of steel components.

$E_s$	=	29,000 ksi	Modulus of Elasticity
$\alpha_s$	=	$6.5 \times 10^{-6}$ in/in/°F	Coefficient of Thermal Expansion

##### 6.2.1.1 Weathering Steel

Use FHWA’s [Technical Advisory 5140.22](#) to determine if AASHTO M270 unpainted weathering structural steel should be utilized in a steel structure.

While designing a plate girder with weathering steel, determine the actual thickness of material that the design needs and then add 1/16 inch. After adding this thickness, round plate thickness to an acceptable thickness as recommended in Table 6.3.2.4 -1. Avoid rounding the plate thickness more than once in the design process.

##### 6.2.1.2 High Performance Steel (HPS)

HPS (typically 70 ksi) steel should be considered when the layout of the structure can be revised to eliminate an entire span, eliminate a girder line (without reducing the number of spans), or reduce the superstructure depth in order to achieve a critical vertical clearance. The use of HPS flanges in a hybrid girder may be used to attain the desired strength. Compare the additional material cost of higher strength steel verses the potential for labor savings in the erection process. Verify the availability of different HPS plate thicknesses being considered. Contact the Structure’s Estimating Support Person to determine HPS costs and availability. When HPS is used on a project, clearly identify the HPS components on the plans.

## 6.2.2 Bolts

AASHTO M253 (ASTM A490) bolts should not be used, unless preapproved by the State Bridge Engineer. They are less ductile and more sensitive to the number of threads in the grip than AASHTO M164 (ASTM A325) bolts. After reaching maximum tension, they tend to “unload” (lose tension) more rapidly than the AASHTO M164 (ASTM A325) bolts.

Type 1 bolts should be used with non-weathering steel and shall be galvanized.

Type 3 bolts should be used with weathering steel.

See Section 6.4.2 for the requirements of bolted field connections.

See Section 14.4.3 for the requirements of anchor bolts for bearing devices.

Anchor bolts for bridge railing shall meet the requirements of Subsection [714.07](#).

## 6.2.3 Stud Shear Connectors

In general, use  $\frac{7}{8}$  inch diameter by 7 inch long studs for shear connectors. Increase the length as needed to account for increased haunch depths due to vertical profile restrictions.

## 6.2.4 Weld Metal

Welding of plates shall conform to the requirements of the AASHTO/AWS D1.5M/D1.5: Bridge Welding Code.

Welding of structural tube shall conform to the requirements of the AWS D1.1/D1.1M: Structural Welding Code – Steel.

## 6.2.5 Paint

### 6.2.5.1 Standard Paint Colors<sup>1</sup>

- For Brown use Color Chip Number 20059.
- For Green use Color Chip Number 14062.
- For Black use Color Chip Number 27038.

#### 6.2.5.1.1 Weathering Steel

The standard paint color for weathering steel on beam and girder bridges is brown.

#### 6.2.5.1.2 Painted Steel

Consider aesthetics and local opinion for municipally owned structures. The standard paint color for state owned trusses is green.

#### 6.2.5.1.3 Bridge Rail

If the bridge rail to be used is black, consider painting the steel deck framing black to match.

---

<sup>1</sup> Federal Standard 595c, January 16, 2008 <http://www.everyspec.com/FED-STD/download.php?spec=FED-STD-595C.005533.PDF>

### 6.3 GENERAL DIMENSION AND DETAIL REQUIREMENTS

#### 6.3.1 Dead Load Camber

Follow AASHTO LRFD 6.7.2 “Dead Load Camber”.

##### 6.3.1.1 Dead Load Camber at Midspan

For the residual dead load camber at the midspan, use the maximum of the following, (see Figure 6.3.1.1 -1):

- The middle ordinate of the crest vertical curve
- 1/8” per 10 feet of span length
- 1”

Note: No minimum residual camber is necessary for sag vertical curves. In the case where haunch depths would be excessive for a cambered or straight beam, negative camber may be appropriate. Large haunches can also be accommodated by taller shear studs or “piggy-backing” studs.

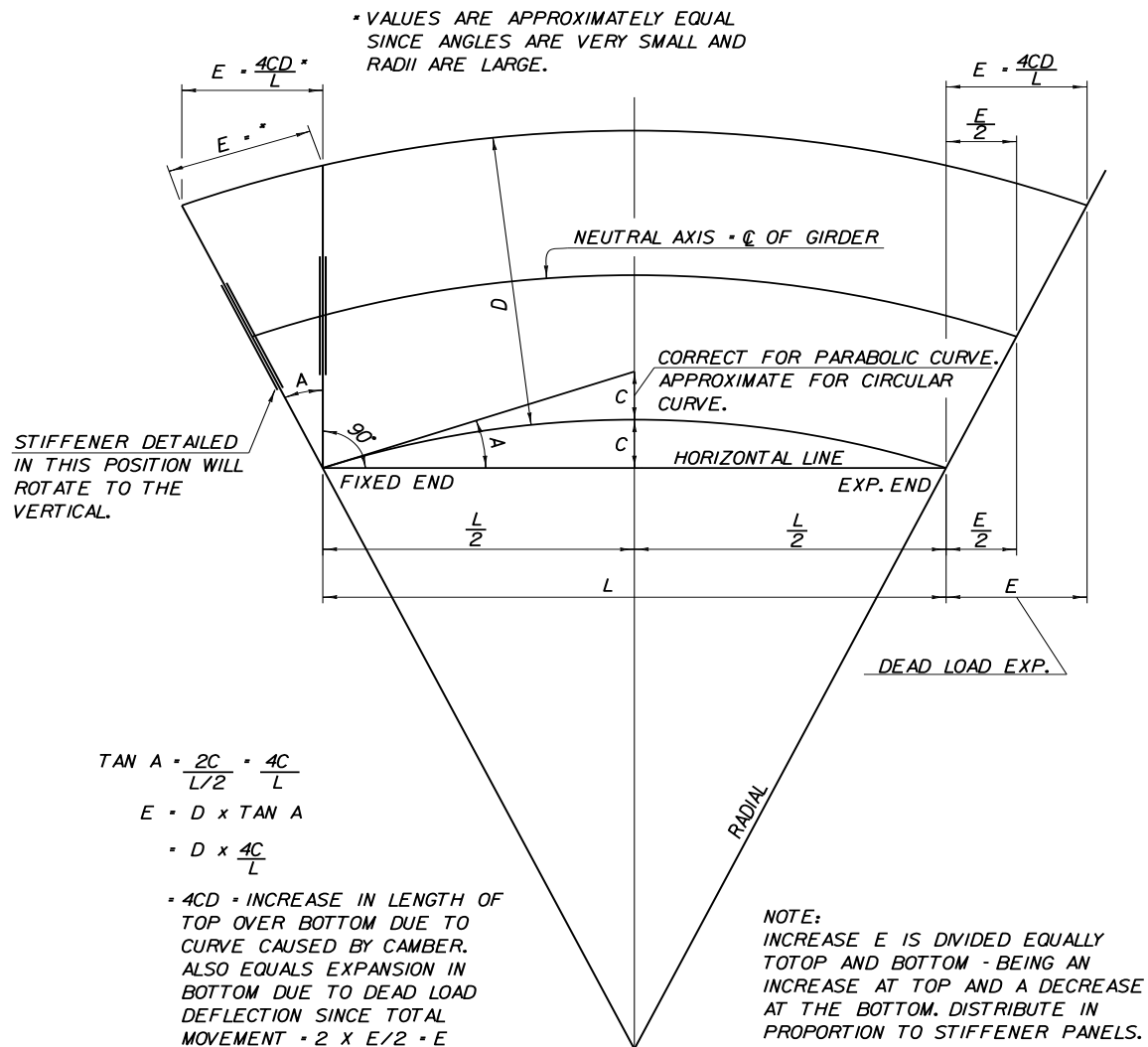

Figure 6.3.1.1 -1 Welded girders principles of girder camber calculations

### 6.3.1.2 Camber Tolerance

Consider the Camber Tolerance when calculating Bearing Elevations. AASHTO M 160M/M 160 covers rolled shapes; Section 3.5 of the Bridge Welding Code covers welded girders; and Section 8.2 of the PCI Design Handbook covers precast elements.

For convenience, some of the common shapes and their tolerances have been compiled in Table 6.3.1.2 -1.

Table 6.3.1.2 -1 Camber Tolerance at Midspan

Element	Range	Tolerance
W shape	≤ 45'	+/- (1/8" per 10 ft ≤ 3/8")
	> 45'	+/- (3/8" + 1/8" x [length(in feet) - 45]/10)
Welded Girder	< 100'	-0" to +3/4"
	≥ 100'	-0 to +1 1/2"
Single and Double Tees	All	+/- (1/4" per 10 ft ≤ 3/4")
Concrete I-beam	All	+/- (1/8" per 10 ft ≤ 1")
Concrete Box beam	All	+/- 1/2"

## 6.3.2 Steel Plate Thickness

### 6.3.2.1 Minimum Thickness

Recommended minimum thickness of structural components:

- Plate Girder Web – ½ inch
- Plate Girder Flange – 7/8 inch
- Transverse Connection Plates – ½ inch
- Gusset Plates – ½ inch
- Structural Tubing (other than downspouts) – ¼ inch

### 6.3.2.2 Maximum Thickness

- Bent connection plates – ¾ inch

### 6.3.2.3 Minimizing Number of Plate Thicknesses

A deck frame comprised of plate girders and cross frames require several individual plates for the assembly. Minimizing the number of different plate thicknesses results in a more efficiently fabricated bridge. The Fabricator is able to reduce equipment setup time and steel plate waste.

### 6.3.2.4 Recommended Plate Thicknesses

Table 6.3.2.4 -1 Acceptable Plate Thickness Ranges

Thickness Range	Increment
3/16 inch to 1 inch	1/16 inch
1 inch to 2¼ inch	⅛ inch
Greater than 2¼ inch	¼ inch

### 6.3.3 Diaphragms and Cross Frames

#### 6.3.3.1 Connection Plates for Diaphragms

Connection plates for diaphragms and cross frames shall extend the full depth of the web and be attached to the flanges.

#### 6.3.3.2 Bearing Diaphragms & Cross Frames

Place Bearing diaphragms or cross frames parallel to the centerline of bearing as much as possible.

Slope cross frames and diaphragms at abutments parallel to the cross slope for ease of forming the transverse haunch.

#### 6.3.3.3 Intermediate Diaphragms & Cross Frames

Generally, intermediate cross frames or diaphragms should be level. If the differential from one end to the other is greater than 6 inches, slope them parallel to cross slope.

For Rolled Beams and Plate Girders from 24 to 48 inches deep, use the [Structural Detail Sheets](#) for guidance on the proper diaphragm size and details.

#### 6.3.3.4 Pier Diaphragms & Cross Frames

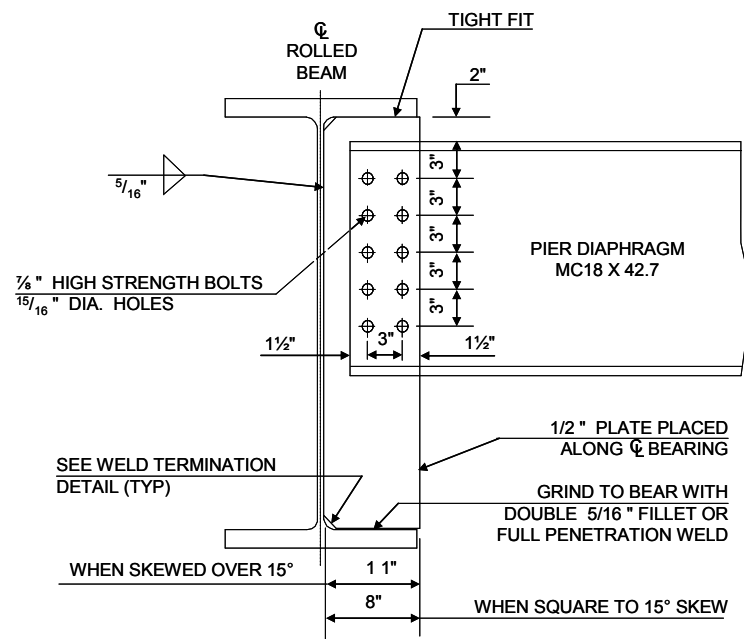

Figure 6.3.3.3.1-1 Pier diaphragms for continuous rolled beam bridges

#### 6.3.3.5 Curved Superstructures

Design cross frames on horizontally curved steel beams as main members. These members shall include adequate provisions for the transfer of lateral forces from the girder flanges. Cross frames and diaphragms for curved beam structures will require the Charpy V-Notch Testing.



### 6.3.4 Lateral Bracing

Check for lateral bracing according to AASHTO LRFD 6.7.5 “Lateral Bracing”. VTrans limits the  $l/r$  ratio of lateral bracing member to 140.

Even if not required by AASHTO, evaluate whether additional lateral bracing will be necessary to provide stability under construction conditions; refer to Section 6.6.4 of this document.

### 6.3.5 Paint

#### 6.3.5.1 Painted Joints

All steel components, including those constructed using weathering steel but excluding those constructed of stainless steel, adjacent to a bridge joint shall be coated. The coating may be a galvanized coating or an approved paint system overtopped with grease. All steel components, including cross frames and connection plates, within a distance, calculated as  $1\frac{1}{2}$  times the depth from finish grade to the bottom of the steel, from the joint shall be coated. A steel component is considered to be adjacent to a bridge joint and requires a coating if a failure of the joint system to convey water off the bridge would result in the steel component becoming wet.

#### 6.3.5.2 Lead Paint

For a rehabilitation project that may have lead paint on members, place the following note on the plans.

“The existing structural steel on this project was painted with a material which may contain lead. The removed structural steel is the property of the Contractor. The Contractor shall indemnify and hold the state, its officers and employees harmless concerning the Contractor’s use or disposition of the structural steel.”

### 6.3.6 Girder Flange Proportions

The recommended minimum plate girders flange width is 16”.

### 6.3.7 Shear Connectors

The clear depth of concrete cover over the tops of the shear connectors should not be less than 2 in or the cover required for the top mat of reinforcing steel.

Shear connectors should penetrate at least 2 in into the concrete deck or completely through the bottom mat of deck reinforcement. Use longer shear studs when haunch depths prevent this.

In the negative moment region, shear studs shall be no further than 2 feet, even if the reinforcing steel is not being counted in the girder-line section.

Design shear connectors for the controlling fatigue limit state, then check the design with the controlling strength limit state.

Avoid placing shear studs on or within 3 inches of a splice plate.

### 6.3.8 Stiffeners

#### 6.3.8.1 Transverse Intermediate Stiffeners

Design girder webs with sufficient thickness to eliminate the need for transverse intermediate stiffeners.

#### 6.3.8.2 Bearing Stiffeners

Design bearing stiffeners according to AASHTO LRFD 6.10.11.2 “Bearing Stiffeners”.

### **6.3.9 Cover Plates**

Cover plates may be used on rolled beams. It is preferable to have the cover plates extend the entire length of the beam. Where this is not practical, they shall not terminate more than 10 feet from the ends of beams.

## **6.4 CONNECTIONS AND SPLICES**

### **6.4.1 General**

In general, bolt all field connections. Avoid field-welded details.

### **6.4.2 Bolted Connections**

All field connections shall be made with  $\frac{7}{8}$  inch diameter high-strength bolt in 15/16 inch diameter holes. The bolts shall meet the requirements of Subsection 714.05 and the installation shall meet the requirements of Section 506.

#### **6.4.2.1 Slip Critical Design**

Design bolted splices as “slip critical” according to LRFD 6.13.2.8. In addition, check all splices as a bearing type connection.

##### **6.4.2.1.1 Slip Coefficients**

Check slices as slip critical connections for Class B or Class C slip coefficients as appropriate.

#### **6.4.2.2 Bolt Detailing**

In general, design joints with bolt threads included in the shear plane. When designing the connection with the threads excluded from the shear plane, verify that this is possible given the bolt length and minimum thread distance. Detail the contact surface of bolted parts as class B or blast-clean surfaces.

### **6.4.3 Welded Connections**

- Use AASHTO/AWS D1.5M/D1.5 “Bridge Welding Code” for weld design and detail (see Figure 6.4.3 -1). Avoid intersecting welds
- Cope stiffeners and connection plates 1 inch horizontal by 3 inch vertical.
- Avoid confined areas for welding, especially for skewed bridges.
- Perform a fatigue analysis on transverse welds on tension flanges even if the flange is not fracture critical.

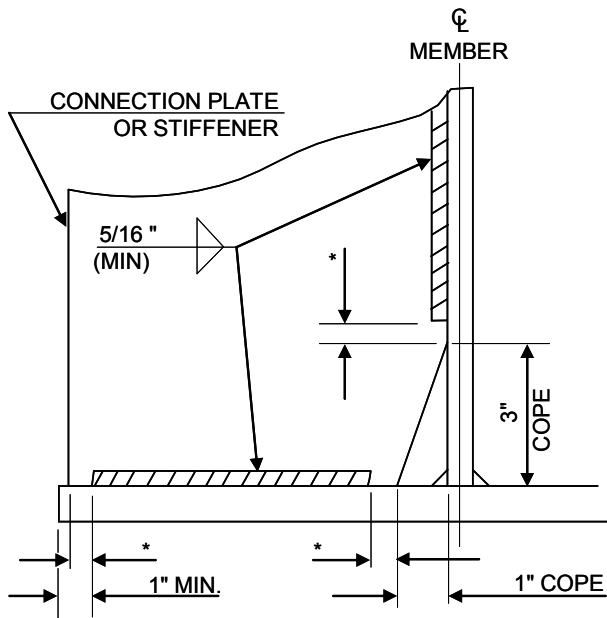

\* NO WELD FOR 3/8" (10 mm) MIN. 7/8" (20 mm) MAX.  
 (EXCEPT MUST MAINTAIN 1" (25 mm) MINIMUM FROM EDGE OF FLANGE)

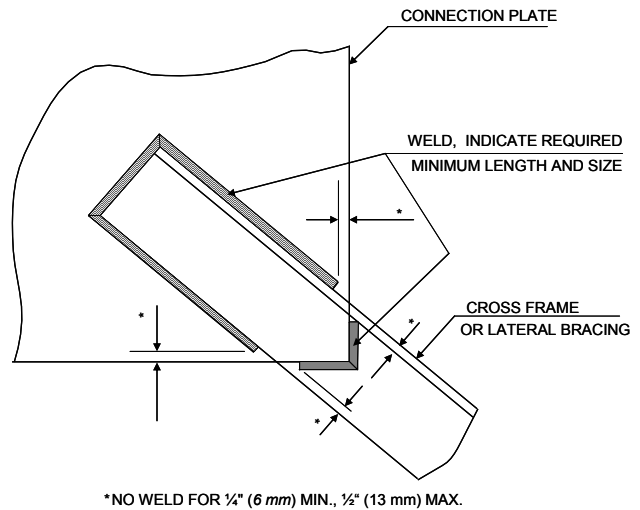

\* NO WELD FOR 1/4" (6 mm) MIN., 1/2" (13 mm) MAX.

Figure 6.4.3 -1 Weld termination and coping details for steel members

Figure 6.4.3 -2 Weld location detail at cross frames and lateral bracing

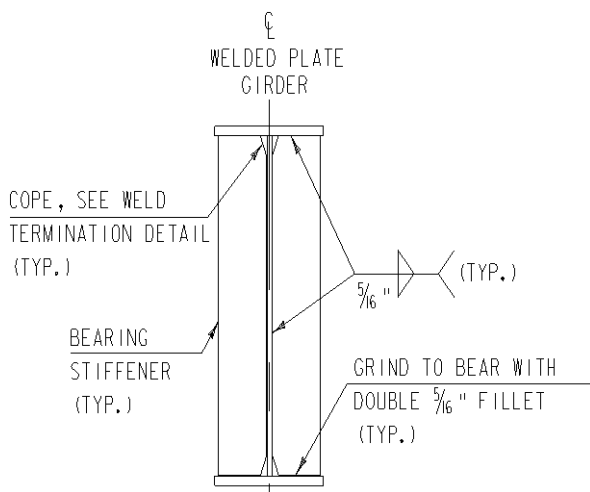

Figure 6.4.3 -3 Abutment bearing stiffeners for welded plate girders

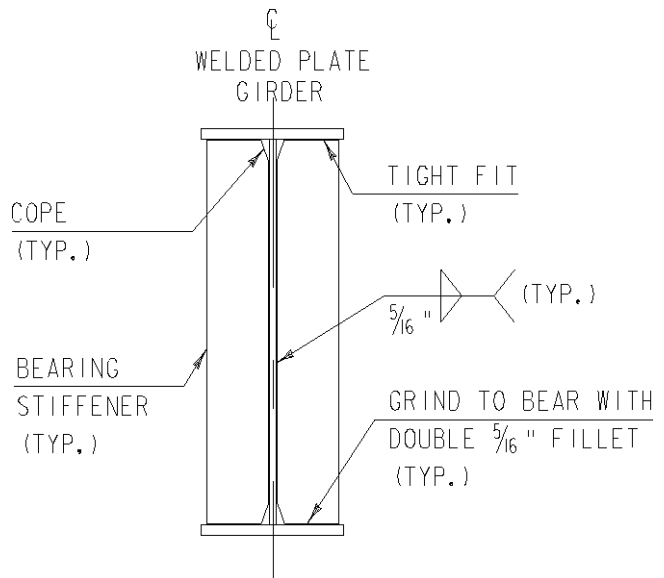

Figure 6.4.3 -4 Pier bearing stiffeners for welded plate girders

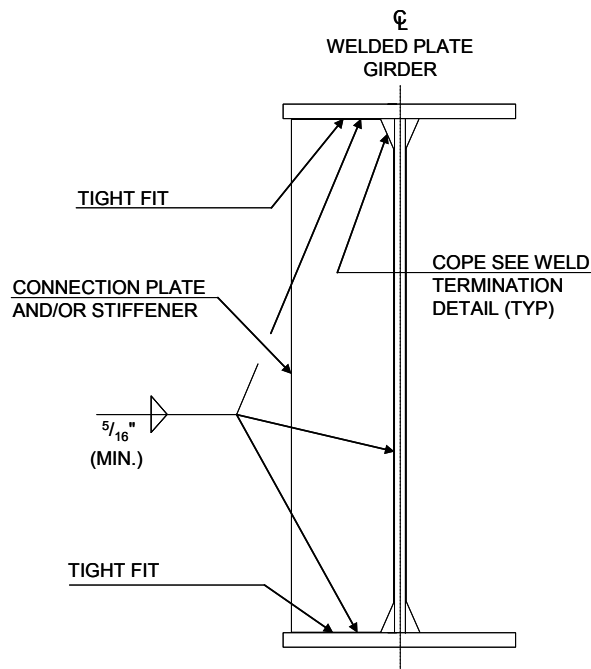

Figure 6.4.3 -5 Intermediate connection plates and/or stiffeners for welded plate girders

Only Shielded Metal Arc Welding [SMAW] processes are acceptable without process and procedure qualification. Refer to the manual “Economic and Fatigue Resistant Details, Participant Handbook” for welded connection details.

#### 6.4.3.1 Weld sizes

AASHTO Section 6 covers minimum and maximum weld sizes. In general, detail 5/16” fillet welds unless this exceeds the maximum allowable size or it is insufficient for design.

### 6.4.4 Splices

#### 6.4.4.1 Maximum Beam Shipping Length

In general, limit shipping lengths to a maximum length of 150 feet. Consider the route the supplier will likely take, delivering the beams to the construction site when determining beam segment length. Route geometry through communities may require limiting the maximum length to something shorter.

#### 6.4.4.2 Span Length Requirements

For lengths of 135 feet to 150 feet, a splice is optional. Design the splice and detail it in the plans, as optional.

#### 6.4.4.3 Splice Locations

When determining the splice locations, consider minimizing the number of splices as practical. Refer to Section 6.4.4.1 for the maximum shipping length limit.

For simple spans or continuous spans where the total girder is less than the maximum shipping length, design the girder for erection as a single segment.

Locate the splice for simple spans greater than the maximum shipping length, at one of the girder’s third points.

For continuous spans where the total length exceeds the maximum shipping length, locate the splice at the point of dead load contraflexure. If the distance to the point of dead load contraflexure is greater than the maximum shipping length, locate the splice at the maximum shipping length. Consider the appropriateness of any splice location other than the expected point of inflection.

#### **6.4.4.4 Axial Capacity**

Section 6.13.6.1.3 of AASHTO LRFD, which permits up to 50 percent of the force in a compression member to be carried through a splice by bearing on milled ends of components, shall not be allowed for the design of field spliced components.

#### **6.4.4.5 Moment Capacity**

##### **6.4.4.5.1 Web Splice**

The web design moment shall be the combination of the following:

- The total design moment multiplied by the net moment of inertia of the web divided by the net moment of inertia of the entire section;
- The moment due to eccentricity of the shear force introduced by the splice connection

In addition to this, the designer must also:

- Investigate bolt load with the bolt in double shear.
- Investigate loads in splice plates based on gross and net section of the plates using appropriate capacities.

##### **6.4.4.5.2 Flange Splice**

Design flange splices for that portion of the design moment not resisted by the web.

- Investigate bolt load with the bolt in double shear.
- Investigate applied loads in splice plates, based on net section of the plate using appropriate capacities.
- Consider filler plates for bolt shear checks.

#### **6.4.4.6 Shear Capacity**

##### **6.4.4.6.1 Plate Girder**

Base the design shear force on the combination of the following:

- The average of the shear force capacity of the web plates on either side of the splice
- Actual shear force at the splice

The result should be greater than or equal to 75% of the shear force capacity of the section.

##### **6.4.4.6.2 Rolled Beam**

Use the design shear force as the actual maximum shear multiplied by the ratio of the splice design moment divided by the actual moment at the splice. This should not be less than 75% of the shear force capacity of the section. Use full depth of the beam for shear.

#### **6.4.4.7 Bolted Splices**

##### **6.4.4.7.1 Non-Composite Areas**

Design bolted splices in non-composite areas according to the following procedure. This procedure requires modifications for the design of a splice in a composite region.

- Determine maximum actual moments and shear values at the splice location (normally near the point of inflection.)
- Assume some bolt pattern in flange and web; determine design section properties for the splice based on the net section of the weakest spliced member.
- Determine design moment and design shear force.

Base the section's design moment on the average of the section's moment capacity on either side of the splice, plus the maximum moment occurring at the splice. This should not be less than 75% of moment capacity of the design section.

#### **6.4.4.8 Welded Splices**

For welded splices, consider the following:

- The thickness of the thinner flange plate at a butt joint should be at least one-half of the thicker plate.
- Vary the flange thickness instead of the width for the required flange area of steel. If a change in width is necessary, use a shop welded butt splice.
- At field connections, use a constant flange plate width.
- In the interest of simplifying fabrication, extending the flange thickness to girder ends or field splice points, in excess of design requirements, is acceptable if the cost is justifiable. The AISC Marketing has a formula for justifying the costs.
- Separate shop flange butt welds and shop web butt welds by at least a 2 feet offset.
- Aesthetics or economics may justify a haunched girder.

## 6.4.5 Gusset Plates in Steel Truss Bridges

The following guidelines shall be adhered to for VTrans Structures projects.

- New steel truss bridges shall be designed such that the connection between members, including gusset plates, welds, pins, and/or bolts, shall meet applicable AASHTO requirements and have the required structural capacity for all applicable load cases. The load cases shall include consideration of the loading of the structure during all phases of construction.
  - Design calculations shall be included in the project design folder or provided by the supplier if the bridge is prefabricated. The original load rating shall include and document rating values for each of the connections. The design and rating calculations for connections in a new structure shall be AASHTO Load and Resistance Factor Design (LRFD) and Load and Resistance Factor Rating (LRF), respectively.
- Rehabilitated truss bridges shall have the structural capacity for all connections between members, including gusset plates, pins, rivets, bolts and/or welds, checked for all applicable load cases for the rehabilitated condition. The load cases shall include consideration of the loading of the structure during all phases of construction.
  - After rehabilitation all connections shall meet applicable AASHTO requirements and have the required structural capacity for all applicable load cases. Existing connections that do not have the required structural capacity shall be replaced. The structural capacity check shall consider section loss and the actual condition of the gusset plates, pins, rivets, bolts and/or welds. The load rating for the rehabilitated bridge shall include and document rating values for each of the connections. The design and rating calculations for connections shall be completed by the same code and methodology as all other components of the rehabilitated structure.
- Existing steel truss bridge load ratings shall be reviewed (to ensure that the capacities of gusset plate connections were/are adequately considered) and shall be re-calculated as determined necessary, when:
  - There is inspector concern (ex. an inspector observes a gusset plate to be smaller/thinner than might be expected when compared to other gusset plates on the structure, gusset plate is showing evidence of buckling, etc.), or
  - Significant sectional area of a gusset plate connection has been lost due to deterioration or significant structural damage has occurred, or
  - The loading is significantly altered by removing or adding dead loads (ex. adding rigid overlay, concrete barrier, etc.), or
  - The loading is significantly altered by increasing the live loading on the structure (ex. increased permit loading).
- The load rating of the connections for existing structures shall include the gusset plates, pins, rivets, bolts and/or welds. The rating shall include and document rating values for each of the connections. The rating calculations for the connections shall be completed by the same code and methodology as all other components of the structure.

### 6.4.5.1 Resistance in Gusset Plates

Gusset plate connections in non-load-path-redundant steel truss bridges shall be analyzed as a part of a bridge load rating analysis. The resistance of a gusset plate shall be decided by the least resistance of the gusset plate in tension, compression, and shear.

Using the LRFR method, the following should be accomplished:

Gusset plates in tension shall be checked for the following:

- Yield on the gross section
- Fracture on the net section
- Block shear rupture

Gusset plates in compression shall be designed according to AASHTO LRFD Articles 6.9.2.1 and 6.9.4 for the LRFD method and AASHTO Article 10.54.1.1 for the LFR method.

Gusset plates in shear shall be checked for the following:

- Shear yield
- Shear fracture

The resistance of the fasteners must also be calculated, with the overall gusset connection resistance to be taken as the smaller of the fastener resistance and the gusset plate resistance.

Design gusset plate connections according to the LRFR standards followed in Part A or the LFR standards followed in Part B of the FHWA Gusset Plate Evaluation Guidance<sup>2</sup>.

---

<sup>2</sup> <http://bridges.transportation.org/Documents/FHWA-IF-09-014LoadRatingGuidanceandExamplesforGussetsFebruary2009rev3.pdf>



## **6.5 FATIGUE AND FRACTURE CONSIDERATIONS**

### **6.5.1 Fatigue**

Avoid non-redundant load path members in structures if possible.

### **6.5.2 Redundancy - Fracture Critical Members**

#### **6.5.2.1 Redundancy**

Redundancy in structures is the ability of a structure to absorb the failure of a main component without the collapse of the structure. Superstructures have three types of redundancy:

- Load path redundancy
- Structural redundancy
- Internal redundancy

With load path redundancy, a member transfers loads to adjacent members or through alternate paths with the failure of any single member. The best example of load path redundancy is a bridge with four or more longitudinal main girders. A typical example of structural redundancy is the interior spans in a continuous span bridge. Indeterminate trusses can also be structurally redundant. Internal redundancy occurs when a girder is composed of a number of components such as angles and plates that are connected by rivets or bolts (not welded). Consider the first load path redundancy in design.

#### **6.5.2.2 Primary and Secondary Members**

Primary members are structural elements designed to carry live load and act as primary load paths. Examples include truss chords, girders, floor beams, stringers, arches, towers, bents and rigid frames. Additionally, lateral connection plates welded to the members listed above, and hangers, connection plates, and gusset plates that support the members listed above are primary members. Curved-girder diaphragms are also included.

Secondary members are structural elements that do not carry primary stress or act as primary load paths.

### **6.5.3 Fracture Critical Members**

Fracture Critical Members are tension members or tension components of nonredundant members whose failure would result in the partial or full collapse of the structure. Tension components include any member that is loaded axially in tension or that portion of a flexural member subjected to tensile stress. Consider any attachment welded to a tension area of a fracture critical member or component to be part of that member or component and, therefore fracture critical. In the case that an element of a tension member fails, the entire member containing the failed element must fail itself in order for it to be classified as a Fracture Critical Member. It is important to realize that members can be nonredundant without being fracture critical (e.g., the compression chord of a truss is nonredundant but it is not fracture critical). It is however not acceptable to attempt to demonstrate that a non-load path redundant member is not a Fracture Critical Member by using internally redundant detailing.

Examples of fracture-critical members or components are tension flanges and webs of two or three girder systems; tension flanges; the tension chords and diagonals of trusses; and floor beams in trusses or thru girders that are spaced more than 12 ft. apart on center. Some columns are fracture critical as defined by the designing engineer.

Examples of non-fracture critical members are all components of the girders in any bridge with four or more girders, the compression chord of a truss and the stringers in a floor system of a thru girder or truss. The designer need not consider two or three girder pedestrian bridges and pedestrian truss bridges fracture critical because they are not subject to high numbers of load cycles.

Avoid designing bridges containing fracture critical members whenever possible. However, in many situations, an adequate alternative to their use may not be available. Vertical clearance restrictions may necessitate the use of thru truss or thru girder structures. In addition, very long spans may be cost prohibitive when attempting to provide a load path redundant structure. Bridges that have fracture critical members have restricted allowable fatigue stress ranges and more stringent fabrication requirements. The VTrans Standard Specifications for Construction address these issues.

### **6.5.3.1 Defining on Plans**

#### **6.5.3.1.1 Fracture Critical Members**

Designers shall designate and provide a table of all fracture-critical members on the contract plans.

Designers shall designate tension zones of all fracture-critical members on the contract plans.

When the Designer has determined that the column or column system is fracture critical, they shall designate all column components as fracture critical on new steel bents where columns experience tension under LRFD Strength III loading.

When the Designer has determined that the column or column system is fracture critical, they shall designate all column-strengthening components as fracture critical on major rehabilitations where a significant portion of the work is associated with the seismic strengthening and/or retrofitting of the structure.

System Redundant Members must also be designated on the design plans. System Redundant Members are members that need not be considered as Fracture Critical Members, but must still be designated on the plans.

For further information on Fracture Critical Members, see [FHWA's Clarification on the Classification of Fracture Critical Members](#).

#### **6.5.3.1.2 Charpy V-Notch Test**

Identify all tensile members and plates requiring a Charpy V-Notch test on project plans by the initials "CVN". All top flanges in integral abutments shall require Charpy V-Notch testing.

If a test is necessary, include the following note.

“Only those members or plates identified with the notation “CVN” must meet the Charpy V-Notch requirements for main members. See Section 714 of the Vermont Standard Specifications for Construction.”

## **6.6 DESIGN PROCEDURES FOR STEEL BRIDGES**

### **6.6.1 Straight Beams**

#### **6.6.1.1 Refined Methods of Analysis**

VTrans provides the following software for the design of a majority of steel beam bridges. Such software includes MERLIN-DASH, RISA-3D and MathCAD sheets.

### **6.6.2 Curved Beams**

Use curved beams or girders only where straight beams or girders are impractical or produce an unacceptable overhang. Design according to the AASHTO LRFD Section 6 as it applies to curved beam bridges. Keep substructures radial if possible, and avoid extreme substructure skews.

#### **6.6.2.1 Refined Methods of Analysis**

Use Opti-Mate's DESCUS software for the design of curved girders. Other programs may be used if approved by the Structures Engineer. As a check on moments and shears, the designer may use a RISA-3D model or a V-Load approximation analysis.

#### **6.6.2.2 Expansion Bearing Orientation**

Allow Expansion according to AASHTO LRFD Section 14.5. Restrain at least two bearings at each substructure unit perpendicular to the direction of expansion.

### **6.6.3 3-Span Continuous Cantilever Bridges**

Use the following criteria for layout and design:

- The span ratio is 1-5-1.
- Balance positive and negative moments with cantilever end loads.
- Determine an acceptable range of cantilever end loadings considering the uncertainty of support conditions at various loading conditions.
- Some support at a cantilever end at loading condition #1, dead load.
- Little or no support, a true cantilever at loadings condition #2, live load.
- Proportion steel girder sections to resist load effects of the design range of cantilever end loadings.
- Allow rotation and translation for expansion at piers.
- Allow expansion at cantilever ends, with closed cell foam behind curtain walls.
- Determine theoretical girder elevations at cantilever ends and splice points at time of girder erection.

### **6.6.4 Construction**

Stability of structural steel during transportation and erection is the Contractor's responsibility. However, designers must ensure that the erection of the structural steel will not require extraordinary means of support. The designer must check the local buckling stress of the compression flange due to steel dead load during erection procedures. The designer will determine the location of field splices (see Section 6.4.4), determine segment lengths and analyze each segment. The stability of the spliced girder is the responsibility of the Contractor. If the calculated design ratio (capacity divided by the applied load) against local compression buckling is less than 1.1, the designer shall increase the area of the compression flange or specify other means of temporary bracing.

## **SECTION 7: ALUMINUM STRUCTURES**

### **7.1 *GENERAL DESIGN***

Refer to LRFD Section 7 for aluminum design consideration.



## **SECTION 8: WOOD STRUCTURES**

### **8.1 GENERAL DESIGN**

See LRFD Section 8 “Wood Structures”, the “ANSI/AF&PA NDS-2005 National Design Specification (NDS) for Wood Construction with Commentary” and “NDS Supplement – Design Values for Wood Construction, 2005 Edition” and the “USDA Forest Service Timber Manual”.

#### **8.1.1 Design Methodology**

Use LRFD to design new wood structures. Rehabilitation design for existing wood structures follows the ASD methodology. Refer to the 4th Edition of the Structures Manual for ASD design considerations.

#### **8.1.2 Live and Dead Loads**

For covered bridges, chose the live load on a project-by-project basis with the Structures Program Manager’s approval. Refer to Section 3 for more details.

For new timber bridges, use live load criteria shall be as for other bridges.

### **8.2 MATERIALS**

#### **8.2.1 Base Resistance and Modulus of Elasticity**

Determine the Base Resistance and Modulus of Elasticity for the proposed wooden material. Allow for the following:

- Deflections according to LRFD
- Connections may control the member size

#### **8.2.2 Preservative Treatment**

##### **8.2.2.1 Requirement for Treatment**

Treat all wood according to LRFD requirements unless approved by the Structures Program Manager.

Use of treated timber in covered bridge rehabilitation shall be at the discretion of the designer.

##### **8.2.2.2 Wearing Surface**

Use bituminous concrete pavement, runner planks or other treatment to protect all timber decks.

The designer may use runner planks for one-way bridges. Evaluate each project for the most appropriate treatment.

##### **8.2.2.3 Timber Deck on Steel Supports**

When a timber deck, either glue laminated or treated timber, is used on steel stringers, the stringers shall be painted steel, not weathering steel.



## SECTION 9: DECK AND DECK SYSTEMS

### 9.1 GENERAL DESIGN

Design the Bridge Decks according to the [Deck Design Tables](#) where possible.

For material not covered in this section, refer to the AASHTO LRFD Section 9.

### 9.2 GENERAL DECK DETAILS

#### 9.2.1 Bridge Rail

The designer shall refer to Section 13 of this manual to select the appropriate bridge rail for the bridge deck, design speed, and other factors.

#### 9.2.2 Curbs

Use curbs on the deck for the following:

- When the deck is paved (see Section 2.7.2)
- When using a curb mounted bridge rail system
- When using fascia mounted rail on a thin deck.

If a curb is not required because of the above, detailing a curb on the bridge cross section is optional.

Curb heights not otherwise designated shall be detailed as 7 inches above finish grade.

##### 9.2.2.1 Curbs on Prestress Deck Beam Bridge Decks

When detailing a butted deck beam bridge typical a full curb may not be necessary. When using Accelerated Bridge Construction methods, a cast-in-place curb will stall the construction progress. In this case, detail a small 10 inch wide pedestal on the fascia of each of the exterior beams. The height of this pedestal need only be the height of the pavement thickness. The precaster will form the pedestal at the precast plant monolithic with the deck beam.

#### 9.2.3 Deck Drainage

Place erosion control on the “downstream” side of any wing wall or drop inlet. Use paving, stone fill, or erosion matting for erosion control.

##### 9.2.3.1 Scuppers

Generally, the designer does not need to use scuppers on structures less than 300 feet in length. These structures should have a full shoulder width that provides sufficient cross-sectional area to carry the design storm runoff. When the structure requires scuppers, place them where they will not discharge onto a roadway underneath or onto the substructures. Flat grades require more scuppers.

On bridges where scuppers are required, consider placing a scupper on the “upstream” side of any joint.

##### 9.2.3.2 Downspouts

In general, galvanized steel downspouts should be used where bridge drainage is required. Fiberglass Reinforced Polymer (FRP) downspouts may be preferable in locations that are difficult to reach for maintenance. However, FRP downspouts should not be used where they may be impacted or are not protected from impact. Downspouts are commonly impacted by ice or debris on wet crossings from below and from winter maintenance activities moving ice and debris from above.





## **SECTION 10: FOUNDATIONS**

### **10.1 *ROCK AND SOIL PROPERTIES***

This manual follows the conventions published in the AASHTO LRFD Bridge Design Specifications Section 10.4. The project plans will use terms set by the Geotechnical Report. The designer will need to ensure the quality of rock or soil is properly translated to the LRFD definition before beginning design.

### **10.2 *LIMIT STATES AND RESISTANCE FACTORS***

Refer to the LRFD Specifications Section 10.5 for more information.

#### **10.2.1 Definitions of Flood Events**

In general, the design flood is the scenario wrought by the 100 year rain event. However, other events which may occur more frequently may have a more adverse impact on the design of a structure; in which case, these more frequent events should be used as the design flood.

Likewise, the check flood is usually the scenario wrought by the 500 year rain event. However, other more frequent rain events may have a more adverse impact on the design of a structure, and those more frequent events should be used as the check flood.

#### **10.2.2 Design Scenarios**

##### **10.2.2.1 Service Limit State**

Foundations, including abutments and piers, shall be evaluated at the Service limit state considering the effects of scour due to the design flood. In addition to other serviceability criteria, tolerable deflections and rotations are calculated at the Service limit state.

Abutments which have been protected by keying in Stone Fill, Type III or Type IV into the toe of the stream without obstructing the river in front of the abutment may be evaluated at the Service limit state without considering the effects of scour due to the design flood.

##### **10.2.2.2 Strength Limit State**

Structural elements of a foundation must be designed to adequately resist the load effects at the Strength limit state considering the effects of scour due to the design flood.

##### **10.2.2.3 Extreme Event Limit State**

Structures must remain standing for an Extreme Event II limit state that considers scour due to the check flood. This limit state need not include earthquakes, ice loads, vehicle collision loads and vessel collision loads simultaneously.

Structures must also remain standing for the Extreme Event I and remaining Extreme Event II limit states without consideration for the effects of scour.

#### **10.2.3 Spread Footings**

Refer to the LRFD Specifications Section 10.6 for more information.

##### **10.2.3.1 Bearing Resistance**

The Geotechnical Engineer usually recommends the bearing resistance for designs. Bearing Resistance for spread footing design should be designed at the strength limit state (10.5.3.2). In lieu of a geotechnical study, use the pressures provided in LRFD Table C10.6.2.6.1-1 as Presumptive Bearing Resistances for Conceptual design.

### **10.2.3.2 Spread Footing on Soil**

Design spread footings on compacted granular material, a natural subsoil of A-2 material or better, or a compacted layer of Granular Backfill for Structures.

- The minimum thickness of any compacted layer underneath a footing shall be 1 foot.
- Remove unsuitable subsoil to a depth recommended by the Geotechnical Engineer.
- Backfill boulder holes with Granular Backfill for Structures.
- Use frost depths from the Flexible Pavement Design Procedure to set dry footings.

#### ***10.2.3.2.1 Abutments***

Abutments founded on spread footings on soil without piles shall be designed with the bottom of footing below the scour elevation for the check flood and the design flood, whichever is lower.

Cantilever abutments founded on piles shall be designed for acceptable joint movement at the service limit state at the design flood scour depth with the backfill forces still acting on the abutment. If stone fill type III or type IV is able to be keyed in without obstructing the river in front of the abutment, the abutment may be designed for acceptable joint movement at the service limit state with no scour. Piles and structure shall be structurally sound at the strength limit state for the design flood and the check flood when fully scoured out.

Integral abutments shall be structurally sound at the strength limit state for the design flood and the check flood when fully scoured out.

#### ***10.2.3.2.2 Piers***

Piers founded on spread footings on soil without piles are not recommended. In general, piers should be founded on deep foundations or spread footings on bedrock.

Piers founded on piles shall be designed for acceptable joint movement at the service limit state at the design flood scour depth. Piles shall be structurally sound at the strength limit state for the design flood and the check flood in the fully scoured condition.

### **10.2.3.3 Spread Footing on Bedrock**

- Extend footings to sound, clean bedrock.
- Using #8 Rebar dowels at 4'-0" centers may be necessary on smooth or sloping bedrock to provide shear resistance.
- Step footings where the bedrock elevation varies significantly along the footing. Steps should be kept to a minimum, have a vertical face, and extend for the full width of the footing. Each step shall be a minimum of 2 feet or the thickness of the footing, whichever is greater. The lower footing shall support the upper footing at the step.

## **10.2.4 Driven Piles**

The Structures Section predominantly uses steel H-piles driven to point bearing on bedrock, or refusal, for pile supported foundations. If sufficient subsurface exploration has been accomplished, other pile types will be considered upon recommendation by the Geotechnical Engineer. Refer to LRFD Section 10.7.

### **10.2.4.1 Pile Bearing Values**

#### ***10.2.4.1.1 Vertical Design Loading***

Vertical design loading for individual piles shall be limited to the following:

- Steel H-Pile:
  - Nominal Pile Bearing Resistance: Use reinforced tip or shoe.
  - Friction: Analyze individually.
  - Design at the strength limit state.
  - The Geotechnical Report will provide the bearing resistance values.
- Other Type Piles:
  - See LRFD Section 10.7

#### ***10.2.4.1.2 Horizontal Design Loading***

Pile groups shall resist horizontal loads applied against footings supported by the piles in the following order of preference:

- Horizontal design of the piles shall be done at the Service Limit State.
- Pile Batter [horizontal component of the axial load]. Pile batter should not exceed 1:4.
- Lateral deflection of the substructure shall be limited to meet the requirements of the joints and bearings chosen. See Section 14.1 for Joint and Bearing limitations.
- Limit the permissible passive resistance accepted by a pile to those values recommended by the Materials and Research Section
- Passive resistance applied to a vertical key projecting below the footing.
- The Geotechnical Report will provide the horizontal Resistance Values.
- For pile groups, refer to LRFD Table 10.7.2.4-1 for using P-multipliers.

### **10.2.4.2 Friction Piles**

Design friction piles according to AASHTO Section 10.7 “Driven Piles”. When the design requires friction piles, specify a Pile Load Test to verify the assumed pile capacity. Materials & Research Unit may recommend a dynamic pile load test. Lateral deflection of the substructure shall be limited to meet the requirements of the joints and bearings chosen. See Section 14.1 for Joint and Bearing limitations.

### **10.2.4.3 Pile Spacing and Clearances**

- Pile spacing shall be according to LRFD Section 10.7.1.2 with consideration to the following limits.
- Maximum pile spacing shall be 10’-0”.
- Minimum pile spacing shall be 2’-6” or 2.5 pile diameters. Piles shall extend a minimum of 1’-0” vertically into the footing.
- Piles shall have a minimum side encasement of 9” from face of footing to face of pile.
- The minimum driven pile length in any substructure shall be 10’-0”.

### **10.2.5 Drilled Shafts**

The Structures Section has started using drilled shafts. Use the Geotechnical Staff at Materials and Research to assist with a drilled shaft design. Refer to LRFD Section 10.8 for more information.

Lateral deflection of the substructures shall be limited to meet the requirements of the joints and bearings chosen. See Section 14.1 for Joint and Bearing limitations.

## **SECTION 11: ABUTMENTS, PIERS AND WALLS**

### **11.1 GENERAL DESIGN**

Refer to AASHTO Section 11 “Abutments, Piers & Walls” for more information.

#### **11.1.1 Design Methodology**

Design all substructures: wing walls, retaining walls, abutments, pier columns and shafts, by the LRFD method.

Spread footing substructures may be design using either the strip method or a total unit design procedure.

Design substructure on pile or drilled shaft foundations as a unit.

#### **11.1.2 Design Economy**

The use of a design that is already prepared, such as a substructure unit slightly conservative in height, can be justified due to the savings in the design time. Consider the following:

- Slope of earth behind the wall.
- Type of soil
- Length of bridge and beam material
- Weight of superstructure
- Live Load considerations
- Bearing resistance
- Selected bridge end detail

When using a previous design on a project, use available software resources, to check the design against the requirements of that project in an efficient manner.

Be mindful however, that tweaking an existing design and its details may loose its economy as more complexities crop up. Try to anticipate such complexities prior to following this path.

### **11.2 SUBSTRUCTURES AND RETAINING WALLS**

#### **11.2.1 Earth Pressure**

Ignore passive pressure acting on the footing toe.

#### **11.2.2 Weep Holes**

Detail 4" diameter weep holes, spaced at a maximum of 10'-0" center to center in abutments and walls. The elevation of these shall be at the highest of either the approximate ordinary low water elevation or 1'-0" above top of footing.

## 11.3 FOOTING DESIGN

### 11.3.1 General Design

Consult the Hydraulics and Geotechnical Sections for determining the depth of abutment and pier footings for wet crossings.<sup>1</sup>

The designer need not bury footings on bedrock. Have the Geotechnical Engineer review bedrock competency.

Consult Figure 11.3.1-1 for locating substructures on piles.

The minimum footing thickness shall be:

- Spread footing - 2'-0"
- Footing on Piles - 3'-0"
- For spread footings on soil the reaction shall be within the middle  $\frac{1}{2}$  of the base & on rock is shall be within the middle  $\frac{3}{4}$  of the base (See LRFD 11.6.3.3)

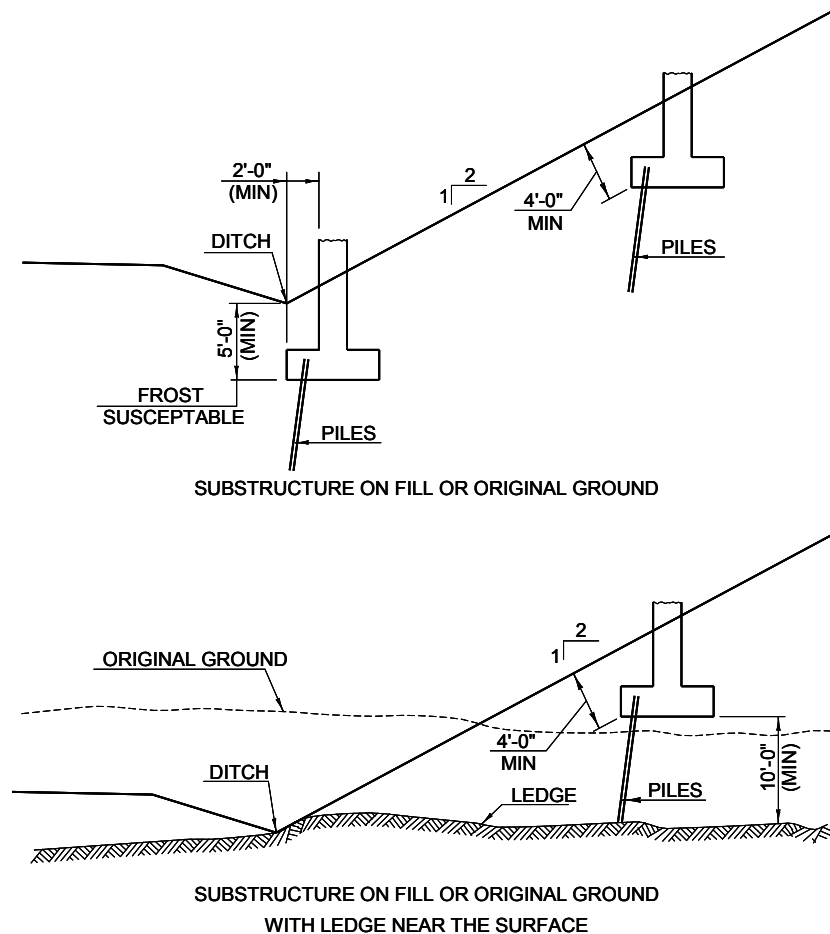

Figure 11.3.1-1 Substructures - Foundation Treatment

<sup>1</sup> Refer also to the policy stated in Structures Engineering Instructions 09-001, from October 30<sup>th</sup>, 2009, at [http://vtransengineering.vermont.gov/sites/aot\\_program\\_development/files/documents/structures/SEI-09-001.pdf](http://vtransengineering.vermont.gov/sites/aot_program_development/files/documents/structures/SEI-09-001.pdf)

### **11.3.2 Toe Design**

Design toe width for stability.

Design the toe reinforcement to resist the moment caused by the upward soil pressure on the footing toe.

Check toe shear at a “d” distance from the front face of the stem.

Generally, the stem rebar extended into the toe is more than adequate for the toe design requirement.

#### **11.3.2.1 Toe Steel**

It is necessary to give special consideration to the area where the abutment steel intersects the wing wall steel.

Insure that the details clearly show an adequate amount of reinforcing and the reinforcing schedule includes that steel.

There are a variety of factors to be considered and the geometry in each case makes it necessary to give special consideration to this part of the substructure design.

It is especially important to detail this area on the project plans in such a way that the resident engineer will know what is intended and will not have to make judgments in the field relative to the reinforcing for this part of the abutment.

Main stem steel shall preferably turn toward the toe.

### **11.3.3 Heel Design**

Design the heel to resist sliding.

Design the heel reinforcement to resist the moment caused by the downward pressures exerted on the heel.

Check heel shear at the back face of the stem. The upward soil pressures may be included in the shear design.

## **11.4 *COMPRESSION MEMBERS WITH OR WITHOUT FLEXURE***

- Comply with the following procedure for pier columns and shafts designed as columns:
- Use the method of analysis according to AASHTO LRFD Bridge Design Specifications to obtain maximum transverse and longitudinal moments plus axial loads at each section under investigation.
- Minimum reinforcement for piers shall be 1% of gross area of design section required, minimum or as specified in LRFD (5.7.4.2).
- For axial loads, generate moment interaction diagrams about the X and Y axes of the trial section.
- Apply moments and axial loads determined in Step 1 to interaction diagrams generated in Step 3.
- Repeat Steps 2 and 3 as required until moment and axial load values plot within the valid design region at Step 4.
- Solid shaft piers not designed as columns are subjected to biaxial bending and axial loads. Moments rather than axial loads usually control the design; therefore, the piers are not compression members, as such. Considering this, flexure in the section becomes the basis of the design.





## **SECTION 12: BURIED STRUCTURES**

### **12.1 GENERAL DESIGN**

Refer to AASHTO LRFD Section 12 “Buried Structures & Tunnel Liners” and the Roadway Design Manual for more information.

#### **12.1.1 Weep Holes**

- Concrete box culverts shall not use weep holes.
- For rigid frames or arches, consider using weep holes or under drain.
- Wing walls for box culverts, rigid frames or arches shall use weep holes. Design Introduction

### **12.2 CULVERT DESIGN**

Use 6'-0" in diameter or larger Structural Plate Pipes or Arches.

#### **12.2.1 Minimum Cover**

Minor drainage culverts should be below subgrade elevation for mainline culverts.

Drive culverts should have a 12 inches minimum cover.

#### **12.2.2 Coatings**

Use galvanized, aluminized or polymeric coating on all steel culverts.

### **12.3 BURIED STRUCTURES AND TUNNEL LINERS**

#### **12.3.1 General Design Features**

Refer to AASHTO Section 12 “Buried Structures and Tunnel Liners” for more design information.

Design Methodology. Use LRFD for all Buried Structures and Tunnel Liners.

#### **12.3.2 Loading**

For vertical pressure from dead load of earth fill (EV), use AASHTO “Rolled Gravel” 140 kcf.

#### **12.3.3 Safety Against Soil Failure**

Check footings for bearing resistance and stability according to AASHTO.

#### **12.3.4 Scour**

Place 6" of select material in the invert unless otherwise required by the ANR. This material simulates a native streambed. Baffles may be necessary to retain it.

#### **12.3.5 Soil Envelope**

Backfill structures with Granular Borrow. Backfill structures to 4'-0" above the structure or to the bottom of the subbase, whichever is less.

Backfill undercut areas with Granular Backfill for Structures or Sand Borrow.

## **12.4 METAL PIPE, PIPE ARCH, AND ARCH STRUCTURES**

### **12.4.1 General**

For Cattle passes, use 96" CAAPP, elongated, and have a 3" paved invert.

Place the entire arch footings on either bedrock or soil.

## **12.5 LONG-SPAN STRUCTURAL PLATE STRUCTURES**

### **12.5.1 General**

For Structural Plate Pipes, Plate Pipe Arches and Arches carrying water, use aluminum with 9.x 2 1/2" corrugations.

### **12.5.2 Safety Against Structural Failure**

#### **12.5.2.1 Acceptable Special Features**

##### **12.5.2.1.1 Continuous Longitudinal Stiffeners**

Continuous reinforced concrete thrust block or metal longitudinal stiffeners at each side of the top arc.

##### **12.5.2.1.2 Reinforcing Ribs**

Reinforcing ribs consisting of structural shapes attached transversely to the structure at intervals, as required, obtaining the necessary composite moment of inertia.

### **12.5.3 Settlement Limits**

Provide a minimum camber of 1/4" per 10 feet.

Add Settlement of the fill at the center of the pipe to the minimum camber.

Prevent camber from causing water to pond at inlets.

### **12.5.4 End Treatment**

#### **12.5.4.1 Cut Ends**

Do not bevel cut ends to match slopes.

Do not skew cut ends.

### **12.5.5 Headwalls**

For all pipes 6 feet and over in diameter, use half height gravity headwalls at the inlet and outlet.

Hydraulics requirements may require a full headwall with improved inlet.

Bury headwalls at least 4 feet.

## **12.6 STEEL TUNNEL LINER PLATE**

Elongation of round pipes shall be 5% vertically.

## **12.7 EARTHWORKS CONSIDERATIONS**

### **12.7.1 Undercuts**

Design all culverts with a minimum of a 12 inch undercut, with the removal of additional unsuitable foundation material as ordered by the Engineer.

### **12.7.2 Backfill Materials**

Backfill all undercut areas with Granular Backfill for Structures. Backfill for culverts shall meet the specification for Granular Borrow.

Extend Granular Backfill for Structures to but not into bottom of subbase.

### **12.7.3 Horizontal Excavation and Backfill Limits**

The Pay Limit for Structure Excavation and Granular Backfill for Structures for all drainage structures with 6 feet or greater spans shall be 3 feet from the face of the structure.



## **SECTION 13: RAILINGS GENERAL DESIGN**

### **13.1 GENERAL DESIGN**

Refer to AASHTO LRFD Section 13 “Railings” for design considerations not covered in this section.

### **13.2 BRIDGE RAIL GUIDANCE**

AASHTO LRFD Subsection 13.4 states that new bridge railings and the attachment to the deck overhang must satisfy crash-testing requirements to demonstrate compliance with structural and geometric requirements of a specified railing test level. AASHTO defines the test levels as follows:

- TL-1 – Test Level One – taken to be generally acceptable for work zones with low posted speeds and very low volume, low speed local streets;
- TL-2 – Test Level Two – taken to be generally acceptable for work zones and most local and collector roads with favorable site conditions as well as where a small number of heavy vehicles is expected and posted speeds are reduced;
- TL-3 – Test Level Three – taken to be generally acceptable for a wide range of high speed arterial highways with very low mixtures of heavy vehicles and with favorable site conditions;
- TL-4 – Test Level Four – taken to be generally acceptable for the majority of applications on high speed highways, freeways, expressways, and Interstate highways with a mixture of trucks and heavy vehicles;
- TL-5 – Test Level Five – taken to be generally acceptable for the same applications as TL-4 and where large trucks make up a significant portion of the average daily traffic or when unfavorable site conditions justify a higher level of rail resistance; and
- TL-6 – Test Level Six – taken to be generally acceptable for applications where tanker type trucks or similar high center of gravity vehicles are anticipated, particularly along with unfavorable site conditions.

The purpose of this document is to provide a detailed methodology for determining the minimum required test level for a site’s bridge rail.

This should be a function of the following:

- Highway design speed
- Average annual daily traffic and percent trucks
- Edge of travel way to face of rail
- Highway geometry (grades and horizontal curvatures)
- Height of deck above crossed surface
- Type of land use below deck

### 13.2.1 Definitions

ADT<sub>dy</sub> Average daily traffic for design year (total for both directions)

K<sub>c</sub> Adjustment factor for horizontal curvature of alignment<sup>1</sup>

K<sub>g</sub> Adjustment factor for grade<sup>1</sup>

K<sub>s</sub> Adjustment factor for deck height and type of land use below deck

ADT<sub>adj</sub> ADT<sub>dy</sub> adjusted for site condition criteria

$$ADT_{adj} = ADT_{dy} * K_c * K_g * K_s$$

#### 13.2.1.1 Procedure for selecting Test Level

- Refer to Figure 13.2.1.1 -1, Figure 13.2.1.1 -2 and Figure 13.2.1.1 -3 to determine K<sub>g</sub>, K<sub>c</sub> and K<sub>s</sub> respectively.
- Calculate ADT<sub>adj</sub>.
- Use Table 13.2.1.1 -1 to determine appropriate Test Level. If the value is less than the value in the TL-4 column, then a TL-2 rail is required, with the following exceptions:
  - If the project is located on the NHS then a minimum of TL-3 is required
  - If the design speed is 50 mph or greater then a minimum of TL-3 is required

#### 13.2.1.2 Bridge and Approach Rail Selection

Bridge and Approach Rails listed in Table 13.2.1.2-1 meet or exceed the test levels determined previously. If none of the Bridge or Approach Rails listed in the table meets the project specific requirements, consult the Structures Engineer for further options.

## 13.3 CONSIDERATIONS FOR PEDESTRIANS

The following shall apply to the selection and location of a bridge railing in combination with a sidewalk.

### 13.3.1 Design Speed of 45 mph or Less:

- The bridge railing type may be selected based on the Test Level required using the procedures as shown above at the fascia side of the sidewalk.

### 13.3.2 Design Speed of 50 mph or Higher<sup>2</sup>:

- Avoid placing the bridge rail on the fascia side of the sidewalk; rather, place the bridge rail between the roadway and the sidewalk. Place a pedestrian railing at the fascia side of the sidewalk. The height of the vehicular bridge rail between the roadway and the sidewalk must meet or exceed the minimum height requirement of a pedestrian railing (42 in). When placing the vehicular bridge railing between the roadway and sidewalk, raising the sidewalk is not necessary. The sidewalk height should be based on the railing configuration and drainage considerations.

---

<sup>1</sup> When a curve begins or ends within the approach rail section of the bridge then adjust these factors for that curve even when the actual structure itself may be on a tangent.

<sup>2</sup> AASHTO LRFD Bridge Design Specifications C13.7.1.1

### 13.4 Average Daily Traffic Adjustment Factors

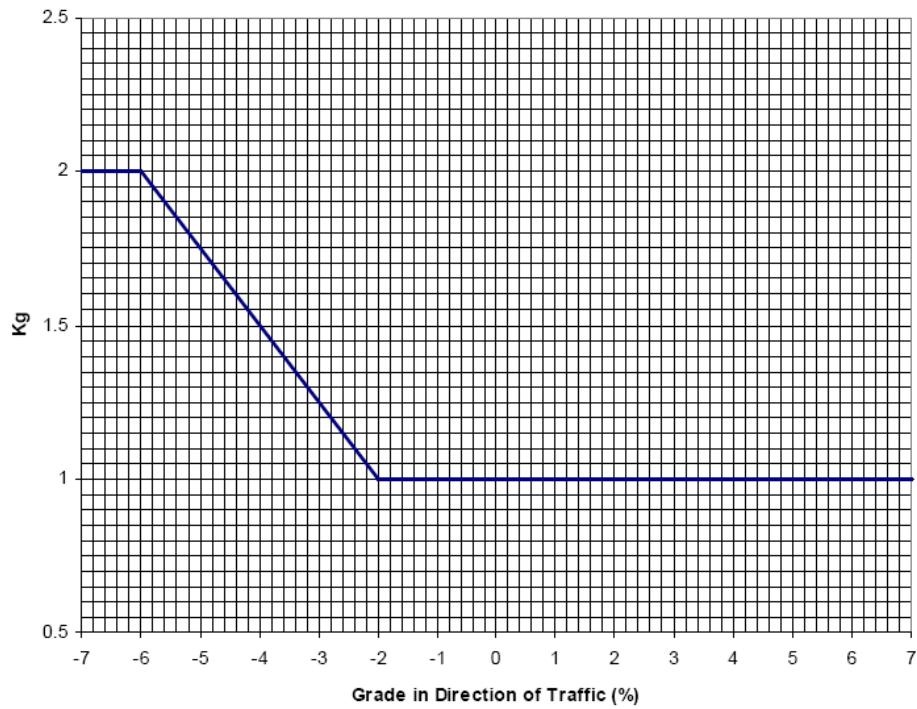

Figure 13.4 -1 Grade Traffic Adjustment Factor (Kg)

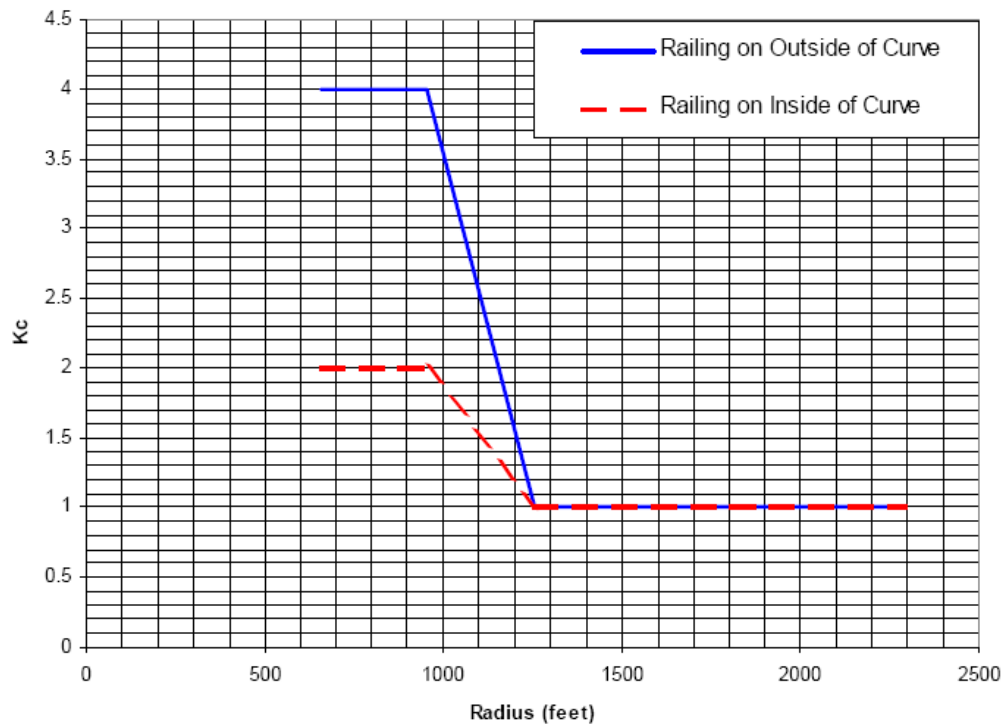

Figure 13.4-2 Curvature Traffic Adjustment Factor (Kc)



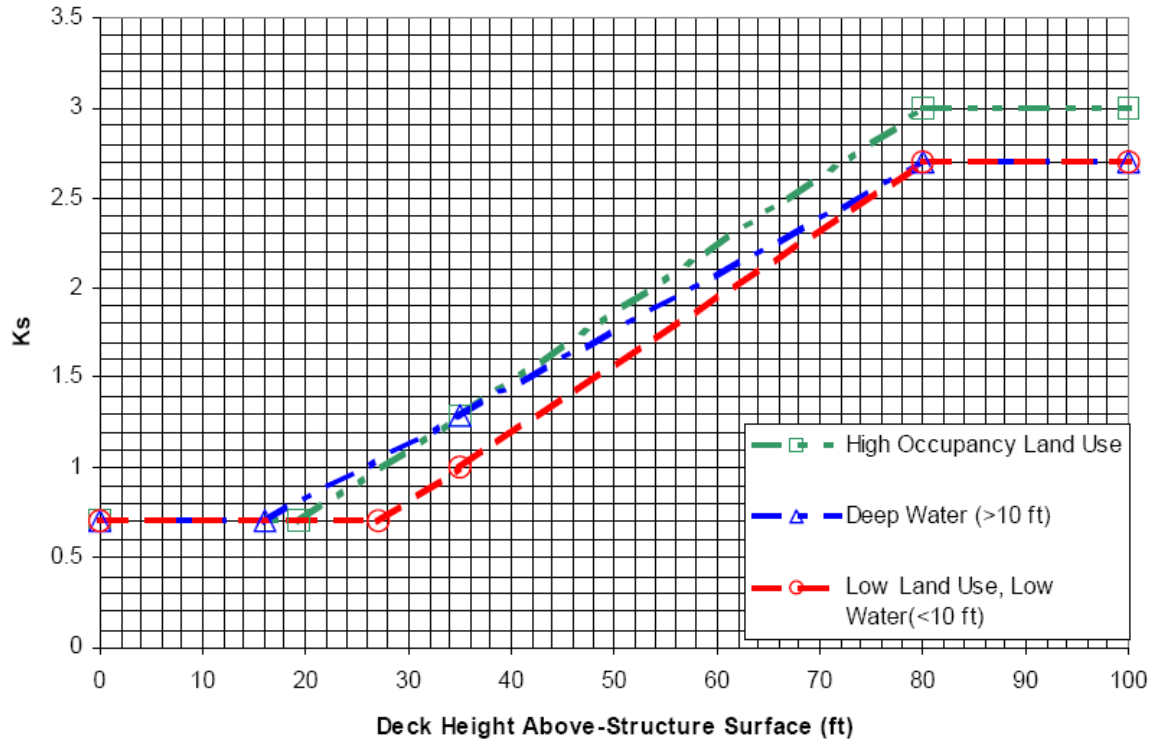

Figure 13.4 -3 Traffic Adjustment Factor (Ks) for Deck Height and Under Conditions

### 13.5 Test Level Selection Table

Table 13.5 -1 Bridge Rail Performance Level Selection

Design Speed (mph)	Percent Trucks (%)	Shoulder Width (ft)	Adjusted ADT for which a TL-4 or TL-5 is required					
			Divided or 5 + lanes		Undivided		One Way	
					4 lanes or less			
			TL-4	TL-5	TL-4	TL-5	TL-4	TL-5
30	0	0 - 3	151000	***	144300	***	75500	***
		3 - 7	283200	***	265200	***	141600	***
		7 - 12	***	***	***	***	316100	***
	5	0 - 3	56600	***	48000	***	28300	***
		3 - 7	90400	***	74600	***	45200	***
		7 - 12	148300	***	128900	***	74200	***
	10	0 - 3	23900	179800	19300	147900	12000	89900
		3 - 7	36500	258300	28800	228700	18300	129200
		7 - 12	55900	404400	46500	364600	28000	202200
	15	0 - 3	15100	102900	12100	84500	7600	51500
		3 - 7	22800	146600	17900	129200	11400	73300
		7 - 12	34400	228500	28300	205300	17200	114300
	20	0 - 3	11100	72000	8800	59100	5600	36000
		3 - 7	16600	102400	13000	90000	8300	51200
		7 - 12	24900	159200	20400	142900	12500	79600
40	0	0 - 3	19000	***	14400	***	9500	***
		3 - 7	24800	***	19000	***	12400	***
		7 - 12	33100	***	27200	***	16600	***
	5	0 - 3	14000	280700	10400	202400	7000	140400
		3 - 7	18000	335100	13400	253800	9000	167600
		7 - 12	24400	452000	19200	366700	12200	226000
	10	0 - 3	9800	79700	7100	55600	4900	39900
		3 - 7	12700	89800	9200	68600	6400	44900
		7 - 12	16900	132400	12800	102300	8500	66200
	15	0 - 3	7500	46400	5400	32200	3800	23200
		3 - 7	9800	51900	7000	39600	4900	26000
		7 - 12	12900	77600	9600	59400	6500	38800
	20	0 - 3	6100	32800	4400	22700	3100	16400
		3 - 7	8000	36500	5600	27900	4000	18300
		7 - 12	10400	54900	7700	41900	5200	27500
50	0	0 - 3	6200	***	4200	***	3100	***
		3 - 7	7200	***	5000	***	3600	***
		7 - 12	9900	***	7300	***	5000	***
	5	0 - 3	5500	162200	3700	107000	2800	81100
		3 - 7	6300	188600	4400	134100	3200	94300
		7 - 12	8400	247300	6100	171900	4200	123700
	10	0 - 3	4700	50000	3200	32000	2400	25000
		3 - 7	5400	61400	3700	41800	2700	30700
		7 - 12	7200	70600	5100	49300	3600	35300
	15	0 - 3	4100	29600	2800	18800	2100	14800
		3 - 7	4800	36700	3300	24800	2400	18400
		7 - 12	6300	41200	4400	28800	3200	20600
	20	0 - 3	3700	21000	2500	13300	1900	10500
		3 - 7	4300	26100	2900	17600	2200	13100
		7 - 12	5600	29100	3900	20300	2800	14600

Table 13.5 -1 Bridge Rail Performance Level Selection (Continued)

Design Speed (mph)	Percent Trucks (%)	Shoulder Width (ft)	Adjusted ADT for which a TL-4 or TL-5 is required					
			Divided or 5 + lanes		Undivided 4 lanes or less		One Way	
			TL-4	TL-5	TL-4	TL-5	TL-4	TL-5
60	0	0 - 3	3200	***	2000	***	1600	***
		3 - 7	3600	***	2300	***	1800	***
		7 - 12	4400	***	2900	***	2200	***
	5	0 - 3	3000	107300	1900	70300	1500	53700
		3 - 7	3300	126300	2100	82800	1700	63200
		7 - 12	4100	158400	2700	105600	2100	79200
	10	0 - 3	2800	39600	1800	25000	1400	19800
		3 - 7	3100	47500	2000	29300	1600	23800
		7 - 12	3900	53100	2500	33700	2000	26600
	15	0 - 3	2700	24300	1700	15200	1400	12200
		3 - 7	2900	29300	1900	17800	1500	14700
		7 - 12	3700	31900	2400	20000	1900	16000
	20	0 - 3	2500	17500	1600	10900	1300	8800
		3 - 7	2800	21100	1800	12800	1400	10600
		7 - 12	3500	22800	2200	14300	1800	11400
70	0	0 - 3	2200	191400	1300	165000	1100	95700
		3 - 7	2400	379100	1500	301500	1200	189600
		7 - 12	2800	***	1700	402400	1400	256400
	5	0 - 3	2100	63100	1300	42200	1100	31600
		3 - 7	2300	80000	1400	51600	1200	40000
		7 - 12	2700	96400	1600	64000	1400	48200
	10	0 - 3	2000	32100	1200	20000	1000	16100
		3 - 7	2300	38500	1400	22900	1200	19300
		7 - 12	2600	42200	1600	26700	1300	21100
	15	0 - 3	2000	21500	1200	13100	1000	10800
		3 - 7	2200	25300	1300	14700	1100	12700
		7 - 12	2600	27000	1600	16900	1300	13500
	20	0 - 3	1900	16200	1200	9700	1000	8100
		3 - 7	2100	18900	1300	10800	1100	9500
		7 - 12	2500	19900	1500	12300	1300	10000

### 13.6 *Approved Bridge and Approach Rail Options*

Table 13.6-1 Bridge and Approach Rail Selection Table

<b>Bridge Railing</b>	<b>Test Level</b>	<b>Height</b>	<b>Approved Standard Drawing (or Reference Detail *)</b>			<b>Pay Item</b>
<b>Guardrail Approach Section</b>						
HDSB/Fascia Mounted/Steel Tubing	2	28"	<a href="#">S-367A</a>			525.44
SB to HDSB - TL3	3		<a href="#">S-367B</a>			621.737
2 Rail Box Beam	4	34"	<a href="#">S-360A</a>			525.33
2 Rail Box Beam	4		<a href="#">S-360B</a>	<a href="#">S-363</a>		621.72
3 Rail Box Beam - curbless	4	33"	<a href="#">S-364A</a>			525.335
3 Rail Box Beam - curbless	4		<a href="#">S-364B</a>	<a href="#">S-364C</a>	<a href="#">S-364D</a>	621.725
4 Rail Box Beam - sidewalk	4	42"	<a href="#">4 Rail Box Beam with Sidewalk</a>			525.34
4 Rail Box Beam	4		<a href="#">4 Rail Box Beam Approach</a>			621.73
Steel Tubing/Concrete Combination	4	42"	<a href="#">S-352A</a>	<a href="#">S-352B</a>	<a href="#">S-352C</a>	525.45
SB to Concrete Rail - TL3	3		<a href="#">S-352D</a>			621.748
SB to Concrete Rail - TL2**	2		<a href="#">SB to Concrete Rail - TL2</a>			621.746
F-Shape Concrete - 32 inch	4	32"	<a href="#">F-Shape Concrete - 32 inch</a>			525.70
SB to Concrete Rail - TL3	3		<a href="#">SB to Concrete Rail - TL3</a>			621.747
F-Shape Concrete - 42 inch	5	42"	<a href="#">F-Shape Concrete - 42 inch</a>			525.70
SB to Concrete Rail - TL3	3		<a href="#">SB to Concrete Rail - TL3</a>			621.747

\* Details of bridge railing without Standard Drawings shall be made project specific and included in the plan set as detail sheets.

\*\* If site conditions warrant a TL2, then the HDSB to Concrete Rail - TL2 may be used.



## SECTION 14: JOINTS AND BEARING

### 14.1 GENERAL DESIGN

Refer to AASHTO LRFD Section 14 for more design information not found in this section.

The influence of dynamic load allowance shall be included for all joints and bearings.

The joints and bearings should allow movement due to temperature changes, creep and shrinkage, elastic shortening due to prestressing, traffic loading, construction tolerances, camber release, substructure deflections and other effects.

Table 14.1.1 Joint Type Movement Table

Joint Type	Longitudinal Movement (in)	Transverse Movement (in)
Plug	2	1
Vermont	3	3
Finger	4	1/4 †
Other	Consult design or manufacturer's specifications	

† Finger configuration can be designed to accommodate slightly more movement.

If movements exceed those listed above, either:

- Choose a different joint type, or
- Document the costs of accepting a potential bearing or joint failure at the site. A risk assessment should include consideration of ADT, operational classification, detour length, economical impacts and any other relevant factors. Verify that a bearing or joint failure will not damage other structural components at the service limit state.

## 14.2 JOINTS

### 14.2.1 Joint Types

#### 14.2.1.1 Modular Expansion Joint

These joint systems are proprietary products used for allowing large movements exceeding 4 inches longitudinally and accommodating some transverse movement. The intent of these systems is to seal the joint throughout the expansion and contraction extremes, while maintaining a smooth driving surface. Consider using this joint when skews and/or lateral movement exceed the capacity of the Vermont Joint using fingerplates.

#### 14.2.1.2 Vermont Joint

The Vermont Joint has a long history in the state of Vermont. VTrans has used this joint for most long span bridges. The joint consists of steel plates that hold down a reinforced fabric trough used to collect water and channel it off the bridge deck. Depending on the width of the expected expansion gap, the designer will choose either the square steel plate or the steel fingerplate. Refer to [Structures Detail SD-516.11](#) series drawings. These provide details and a “Joint Gap Dimension Table” based on temperature and expansion length.

##### 14.2.1.2.1 Square Plate Vermont Joint

Use the square plate Vermont joint when end of bridge expansion movement is less than 3 inches.

### 14.2.1.2.2 Finger Plate Vermont Joint

Use the fingerplate Vermont joint when end of bridge expansion movement exceeds 3 inches.

### 14.2.1.3 Asphaltic Plug Joint

The joint is the thickness of the bituminous concrete pavement and is essentially joint sealer hot poured with binder aggregate in sealer over a steel plate to support vehicles. This joint can accommodate movement up to 1 inch. Refer [Structures Detail SD-516.10](#) Series.

### 14.2.1.4 Pavement Saw Cut Joint

Install a pavement saw cut joint as a controlled crack in the pavement over concrete joints or where concrete slabs terminate, or other locations where network cracking may be expected. This joint does not allow for significant expansion. See Figure 14.2.1.4 -1 and Figure 14.2.1.4 -2.

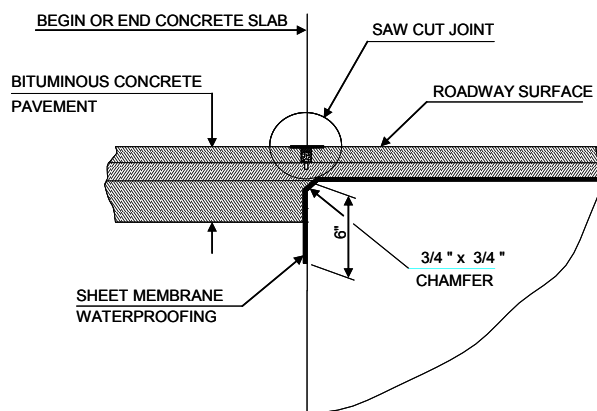

Figure 14.2.1.4 -1 Saw Cut Joint Detail

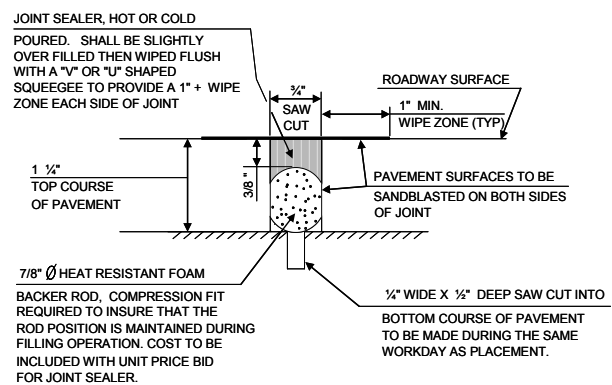

Figure 14.2.1.4 -2 Saw Cut Joint Detail Close Up

#### 14.2.1.4.1 Saw Cut Joint Note

The following note shall be included with the plans if using saw cut joints.

The Joint is to be located accurately by string lining, or other means, prior to paving, so that the saw cuts will be made directly over the end of concrete deck. Cut the joint dry in a single pass and seal within a 24 hours period or prior to exposing to traffic. Clean the joint prior to applying the joint sealer. Refer to specification 524 and the special provisions.

### 14.3 BEARINGS

#### 14.3.1 Requirements for Bearings

##### 14.3.1.1 Horizontal Force and Movement

##### 14.3.1.1.1 Coefficients of Friction

Table 14.3.1.1.1 -1 Coefficients of Friction for Bearing Materials†

Materials	Coefficient
Steel on Steel	0.15
Steel on Self-Lubricating Bronze	0.10
PTFE on Stainless Steel	0.06

†See Table 3.11-1 and LRFD Table 14.7.2.5-1 for more coefficients of friction values.

##### 14.3.1.1.2 Curtain Walls

Provide a box-out as detailed in Figure 5.3.9-1, Figure 14.3.1.1.2 -2 and Figure 14.3.1.1.2 -3 for bridges designed with a curtain wall.

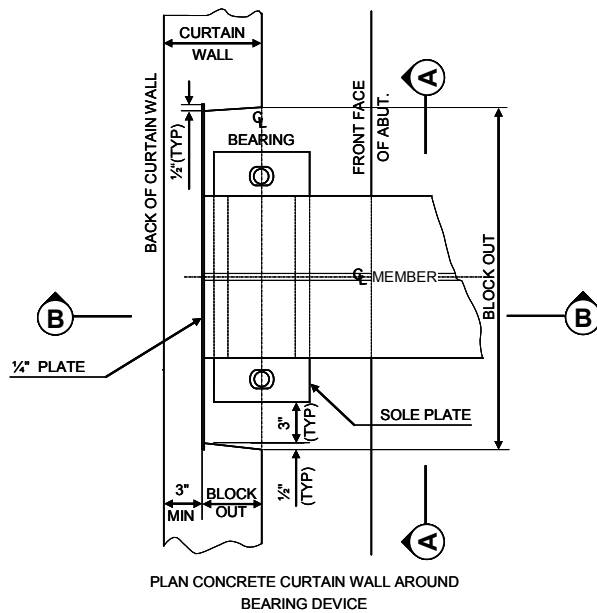

Figure 14.3.1.1.2 -1 Plan detail of Curtain Wall Bearing Box Out



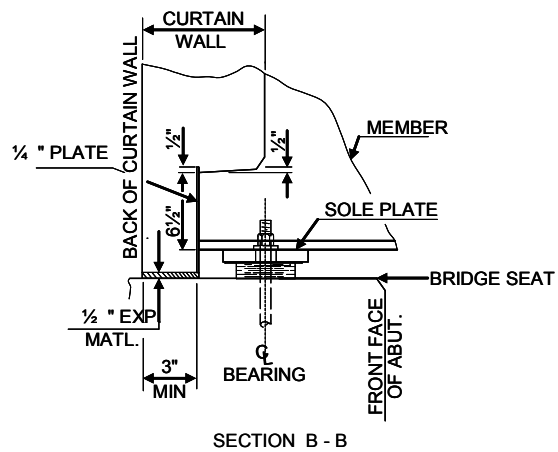
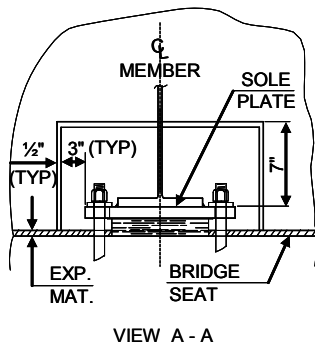

Figure 14.3.1.1.2-2 Elevation Detail along Curtain Wall for Bearing Box Out

Figure 14.3.1.1.2-3 Elevation Detail along Beam for Curtain Wall Bearing Box Out

### 14.3.2 Prestressed Deck Beam Bearing Layout

All box beams and voided slabs will require the use of two elastomeric bearing pads per end. Figure 14.3.2-1 shows the standard bearing placement detail

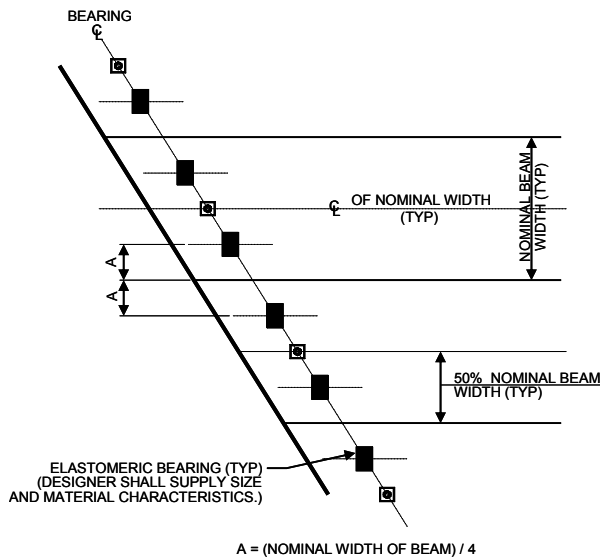

Figure 14.3.2-1 Layout of bearings for all spans.

## 14.4 LOAD PLATES AND ANCHORAGE FOR BEARINGS

### 14.4.1 Plates for Load Distribution

#### 14.4.1.1 Material

Use AASHTO M 270 Grade 36 steel for sole and base plates, unless the design requires higher strength steel by design.

### 14.4.1.2 Holes

Holes in the base plates and sole plates shall be a minimum of  $\frac{3}{8}$ " larger in diameter than the nominal diameter of the anchor bolt.

Expansion bearings require slotted holes.

### 14.4.1.3 Sole Plates

The minimum sole plate length is the bottom flange width plus 9".

The minimum sole plate thickness for plates attached to elastomeric bearings is 1½". The minimum sole plate thickness for all other bearings is 1".

## 14.4.2 Tapered Plates

If, under full unfactored permanent load at the mean annual temperature for the bridge site, the inclination of the underside of the girder to the horizontal exceeds 0.01 radians and  $\frac{1}{8}$ " across the length of the sole plate, use a tapered plate to provide a level surface.

Calculate the inclination from the grade and camber.

## 14.4.3 Anchorage and Anchor Bolts

Anchor bolts for bearing devices shall meet the requirements of Subsection [714.08](#).

- The minimum anchor bolt diameter is 1½".
- The minimum length of embedment is 15".

For Fixed End Anchor Bolts, hand tighten the nut, and burr the threads above the nut.

For Expansion End Anchor Bolts, leave a  $\frac{1}{8}$ " gap below the nut, and burr the threads above the nut.

## 14.5 SPECIAL DESIGN PROVISIONS FOR BEARINGS

### 14.5.1 Metal Rocker and Roller Bearings

Avoid the use of high "rocker" type steel expansion bearings.

### 14.5.2 Steel-Reinforced Elastomeric Bearings – Method A

Steel-Reinforced Elastomeric bearings are suitable for a wide range of transverse and longitudinal movements and rotations. As such, they should be the first bearing considered.

The minimum length of the sole plate is the bearing length plus the total travel plus 3".

Use a construction tolerance of +/- 0.010 radians.

For permanent applications, specify a minimum low-temperature elastomer grade of 4.

### 14.5.3 Pot Bearings

Pot bearings are suitable in many of the applications where steel-reinforced elastomeric bearings are unsuitable, i.e. for high transverse, longitudinal and vertical loads.

The minimum design rotation is 0.015 radians.

The maximum design rotation equals the construction tolerance of +/- 0.010 radians, plus the rotation due to live load deflection.

Expansion bearings of the pot type shall have a stainless steel surface attached to the sole plate and a Teflon surface attached to the top of the piston.

## **14.6 *CORROSION PROTECTION***

Galvanize or metalize all structural steel components of bearing devices, except the inside of pots. Shop drawings must indicate whether the bearing device is to be galvanized or metalized. If using metalizing, the shop drawings must also denote the type of seal coating that will be placed on the metalizing.

## **14.7 *DETAILING BEARINGS***

Place a table on the plans to indicate the bridge seat elevations for each bearing. In addition, designers will continue to provide elevations at the fascias and centerline for each abutment.

Some Bearing configurations will require a placement table with relation to the temperature the structure will be set.

## **14.8 *PAYMENT FOR BEARINGS***

Pay for bearings as a separate item, each pad is one bearing.

## **SECTION 15: LOAD RATING**

### **15.1 GENERAL**

Follow the most recent edition of the AASHTO “Manual for Condition Evaluation and Load and Resistance Factor Rating (LRFR) of Highway Bridges, and its latest interims (LRFR).

Load rate new structures with their full dimensions given in the plans.

Various computer programs used in Structures can assist with load rating most types of superstructures.

Some structure types, such as slant leg steel rigid frames, must be load rated manually with the use of live load influence lines.

### **15.2 LOAD RATING METHODOLOGY FOR HIGHWAY PROJECTS/ EXISTING BRIDGES<sup>1</sup>**

All new or rehabilitated bridges or buried structures designed using the AASHTO LRFD methodology shall be load rated using AASHTO Load and Resistance Factor Rating (LRFR).

New or rehabilitated bridges or buried structures designed using the AASHTO Standard Specifications and the LFD methodology shall be load rated using AASHTO Load Factor Rating (LFR). Rehabilitated historic metal and/or timber trusses and historic arches bridges designed using the AASHTO Standard Specifications and the ASD methodology shall be load rated using AASHTO Allowable Stress Rating (ASR).

Rate existing bridges and buried structures on the NHS using either the AASHTO LFR or LRFD as determined by the Bridge Management and Inspection Engineer. Rate existing and historic timber bridges and historic arches on the NHS using the AASHTO Allowable Stress Rating (ASR).

Rated existing bridges and buried structures not located on the NHS using AASHTO LFR, ASR or LRFD as determined by the Bridge Management and Inspection Engineer. However, rate existing and historic metal and/or timber bridges and historic arches using the AASHTO Allowable Stress Rating (ASR).

---

<sup>1</sup> Policy as stated in Structures Engineering Instructions 08-005 (7/9/08)

REACTIONS SHOWN ARE PER WHEEL LINE.

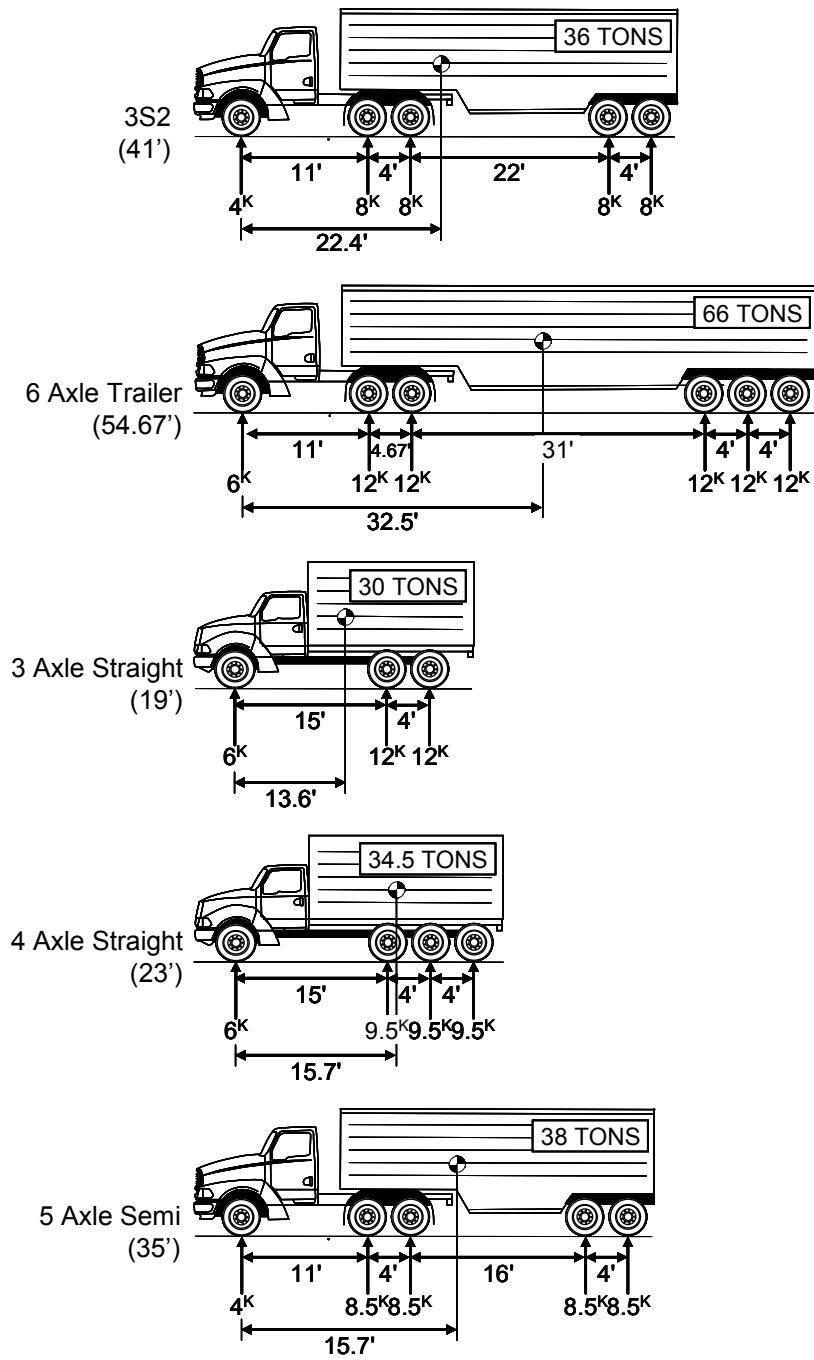

Figure 15.2-1 Vermont Standard Load Rating Trucks

### 15.2.1 Vehicular Live Loads

The Design Data block on the PI Sheet should contain the ratings for the H-20 and HL-93 vehicles as shown in Figure Section 15:-1 as well as for each of the vehicles shown in Figure Section 15:-2. The data block should only report the lowest or critical rating factor for each truck.

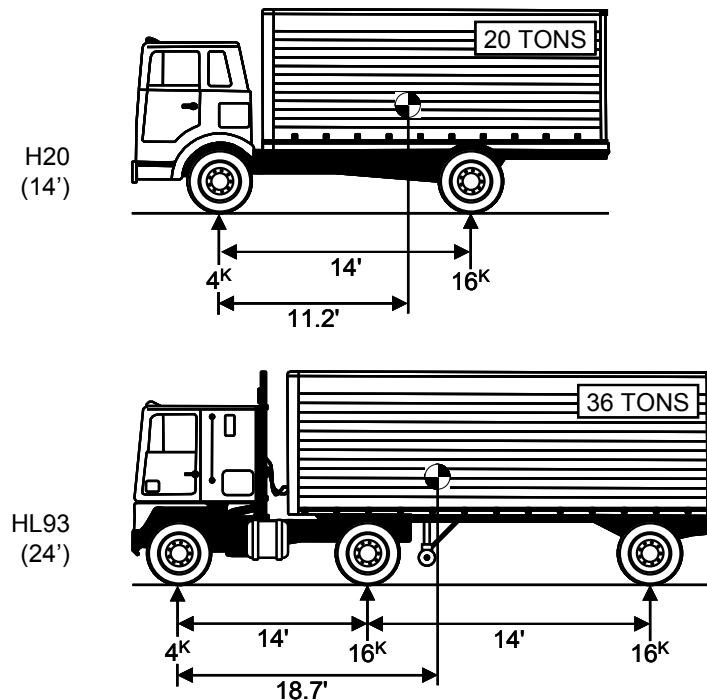

Figure 15.2.1-1 The AASHTO Standard Trucks

#### 15.2.1.1 Rating in Tons

- See LRFR 6.4.4.4 “Rating in Tons”

## 15.3 WORKING STRESS AND LOAD FACTOR DESIGNS

See LRFR Section 6 “Load and Resistance Factor Rating”, Appendix D.6.1 “Alternate Load Rating”.

Follow the 2004 VTrans “Structures Division Manual” 4th Edition. See Chapter 24 “Load Rating”.

## 15.4 LOAD AND RESISTANCE FACTOR RATING

Follow LRFR Section 6 “Load and Resistance Factor Rating”.

### 15.4.1 Load Rating Buried Structures

Load Rate buried structures with spans over 20’-0” for all State Legal Loads. Buried structures with spans in the range of 6’-0” to 20’-0” need not be load rated.

## 15.5 LOAD RATING PROCEDURES

See LRFR 6.4.2 “General Load-Rating Equation”



## APPENDIX A: REPORT AN ERROR OR MAKE A SUGGESTION

Please copy this page and fill out.

Section Number: \_\_\_\_\_

Name: \_\_\_\_\_

Affiliation: \_\_\_\_\_

Please place an X beside category

\_\_\_\_\_ Typographical Error in Text

\_\_\_\_\_ Formatting problem

\_\_\_\_\_ Wording is confusing

\_\_\_\_\_ Text inaccurate

\_\_\_\_\_ Wrong Units

\_\_\_\_\_ Inaccurate Information

\_\_\_\_\_ Inaccurate reference

\_\_\_\_\_ Equation wrong

Other: \_\_\_\_\_

Comment or Suggestion: (Continue on back if necessary)







